

---

# PJ10KPS-C

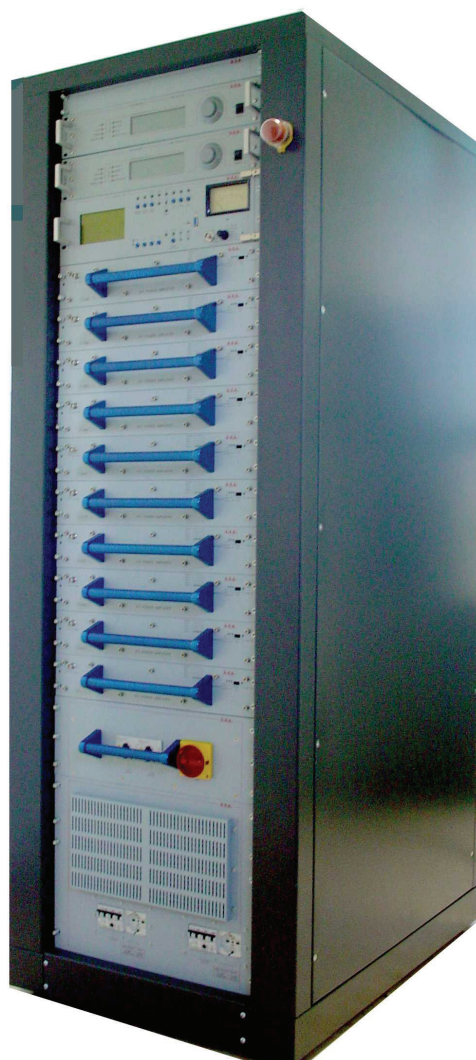

**Manuale Utente**

**Volume 2: Appendice Tecnica**

---

Manufactured by



Italy



## APPENDICE TECNICA:

### Piani di montaggio, Schemi elettrici, Liste componenti

Questa parte del manuale contiene dettagli tecnici riguardanti la costruzione delle singole schede componenti del PJ10KPS-C.

L'appendice è composta dalle seguenti sezioni:

<i>Descrizione</i>	<i>Codice RVR</i>	<i>Vers.</i>	<i>Pag.</i>
<b>Modulo R.F.</b>	SLRFPJ1KM	1.0	3
<b>Accoppiatore Direzionale Modulo R.F.</b>	SLDCLPFPJ1KM	1.1	6
<b>Scheda Misure Splitter Ingresso</b>	SLSPLMEA5KW1	1.0	9
<b>Splitter Modulo R.F.</b>	SLSPLRFPJ5KM	1.0	12
<b>Scheda Fusibili Modulo R.F.</b>	SLFUSRFPJ5KM	1.0	15
<b>Scheda Misura Sbilanciamento</b>	SLPWRSENHC52	1.0	18
<b>Selettore Misura Analogica</b>	SLMETPJ5KM4	1.0	21
<b>Interfaccia I/O Modulo R.F.</b>	SLIORFPJ5KM2	1.1	24
<b>Accoppiatore Direzionale di Uscita</b>	SLPWRMTRHC51	1.0	27
<b>Interfaccia Relé di Potenza</b>	SLRLYCPROTVJ	1.0	30
<b>Scheda Emergenza CCU</b>	SLCCUEMPJ5K2	1.0	33
<b>Scheda Microcontrollore</b>	SLCUPPJ5KM2	1.0	36
<b>Adattatore Cpu PS e Combinatore</b>	SLADPPSPJ5KM2	1.0	41
<b>Scheda Rettificatrice Trifase</b>	SLRCTPJ5KMC	1.1	45
<b>Scheda Unità di Controllo CPU</b>	SLCCUPJ5KM2	1.0	48
<b>Scheda Unità di Controllo Madre</b>	SLCCU1PJ5KM2	1.0	53
<b>Interfaccia Parallela</b>	SLINTREMPJ5KM	1.0	56
<b>Splitter/Scambiatore Ingresso</b>	CSSPLINA10K2 – CSSPLINB10K2	1.0 1.0	60
<b>Scheda CPU Misure Sbilanciamento</b>	SLADKDIPJ5K2	1.0	63
<b>Adattatore CPU/Bias Modulo R.F.</b>	SLADBSPJ5KM2	1.1	66
<b>Driver Modulo R.F.</b>	SLDRVRFPJ5M	1.0	71
<b>Alimentatore Switching Modulo R.F.</b>	PSSW5040	1.2	74
<b>Circuito 380 Volt</b>	3FRCKPJ10KMC	1.0	<b>Errore. Il segnalibro non è definito.</b>
<b>Circuito Rettificatore Carrello 380 Volt</b>	3FRECTPJ10KM	1.0	<b>Errore. Il segnalibro non è definito.</b>
<b>Circuito Bassa Tensione e Segnali</b>	LOWTENPJ10KM	1.0	<b>Errore. Il segnalibro non è definito.</b>

MODULO R.F.

SLRFPJ1KM

PIANO DI MONTAGGIO

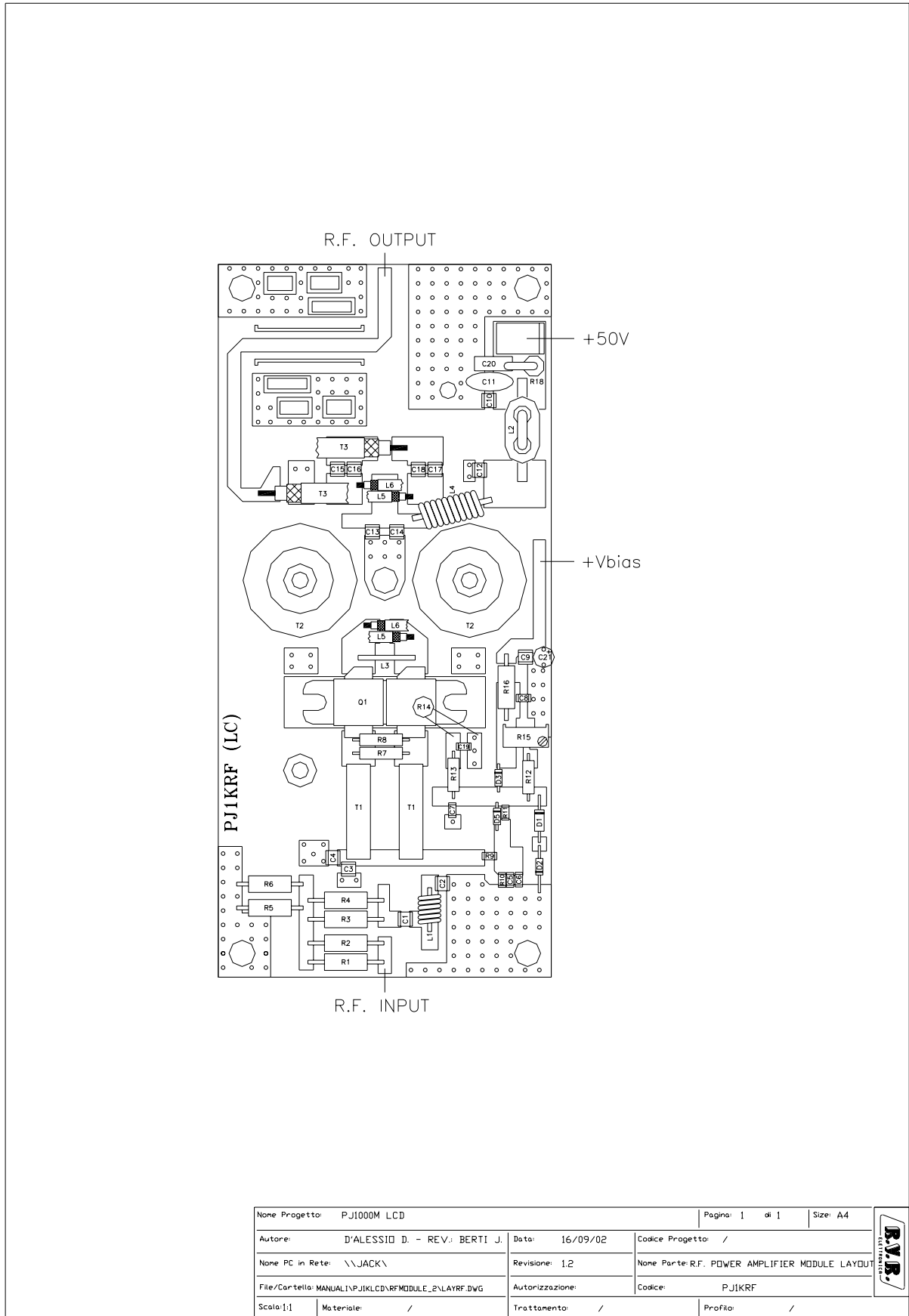

Nome Progetto: PJ1000M LCD		Pagina: 1 di 1	Size: A4
Autore: D'ALESSIO D. - REV.: BERTI J.		Data: 16/09/02	Codice Progetto: /
Nome PC in Rete: \\JACK\		Revisione: 1.2	Nome Parte: R.F. POWER AMPLIFIER MODULE LAYOUT
File/Cartella: MANUALE\PJKLCD\RFMODULE_2\LAYRF.DWG		Autorizzazione:	Codice: PJKRF
Scala: 1:1	Materiale: /	Trattamento: /	Profilo: /



SCHEMA ELETTRICO

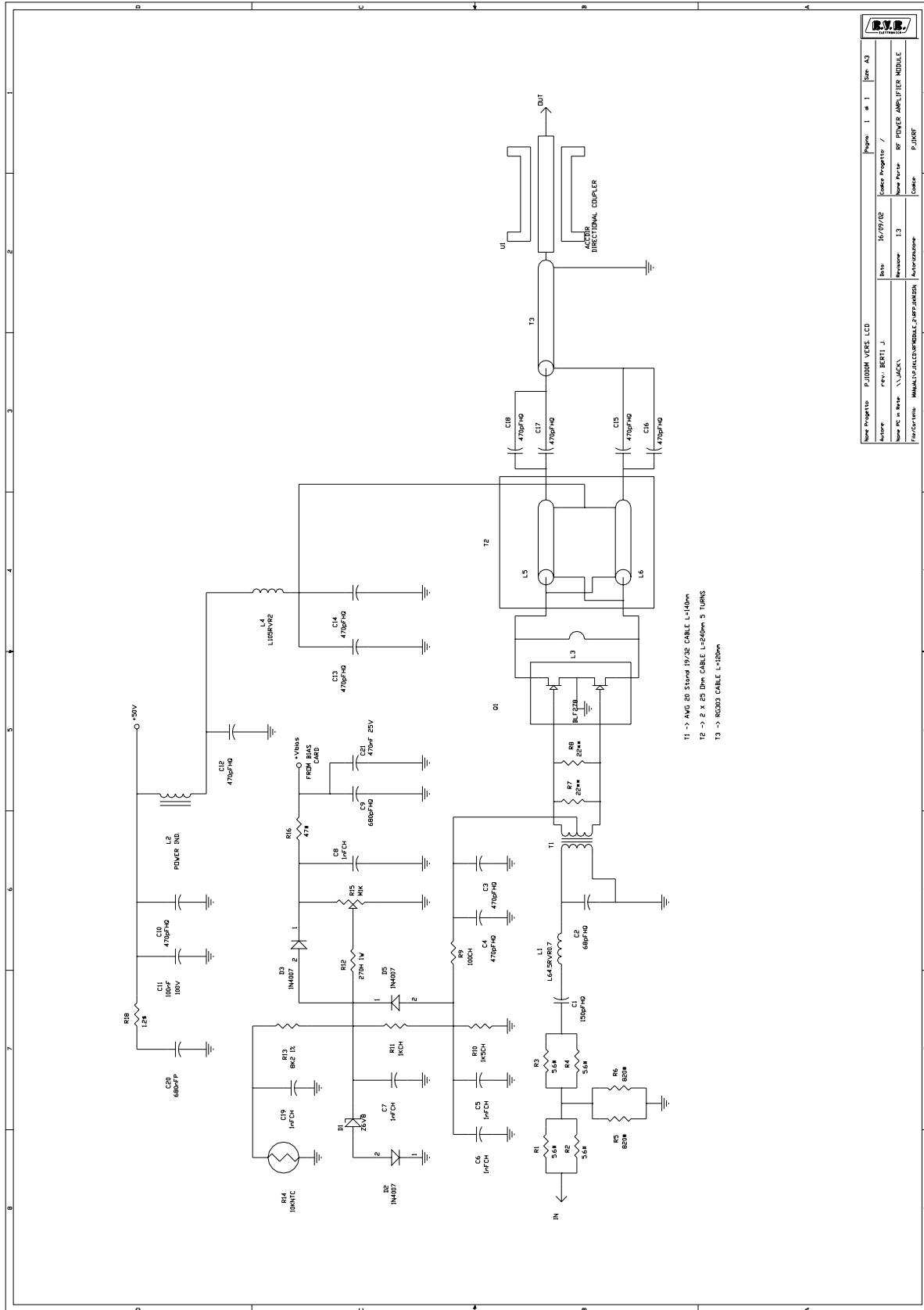

R.V.A. ELETTRONICA		Page: 1 of 1	Rev: A3
Nome Progetto	PJ10KPS VCRS_LCD	Data Progetto	15/09/02
Autore	rev. BERTI J.	Nome Proie	RF POWER AMPLIFIER MODULE
Nome File in Rete	N:\RACK	Revisione	13
Funzione	MANUALI ELETTRICI ELETTRONICA	Autore	PJ10KPS

## LISTA MATERIALI

Item	Quantity	Reference	Part
1	2	L6, L5	
2	1	C1	150pFHQ
3	1	C2	68pFHQ
4	10	C3, C4, C10, C12, C13, C14, C15, C16, C17, C18	470pFHQ
5	5	C5, C6, C7, C8, C19	1nFCH
6	1	C9	680pFHQ
7	1	C11	100nF
8	1	C20	680nFP
9	1	C21	470nF 25V
10	1	D1	Z6V8
11	3	D2, D3, D5	1N4007
12	1	L1	L64.5RVR0.7
13	1	L2	POWER IND.
14	1	L3	BU6012RVR2
15	1	L4	L105RVR2
16	1	Q1	BLF278
17	4	R1, R2, R3, R4	5.6#
18	2	R5, R6	820#
19	2	R8, R7	22**
20	1	R9	100CH
21	1	R10	1K5CH
22	1	R11	1KCH
23	1	R12	270H 1W
24	1	R13	8K2 1%
25	1	R14	10KNTC
26	1	R15	M1K
27	1	R16	47#
28	1	R18	1.2\$
29	1	T1	4:1
30	1	T3	RG303
31	1	U1	ACCDIR

ACCOPIATORE DIREZIONALE MODULO R.F.

SLDCLPFPJ1KM

PIANO DI MONTAGGIO

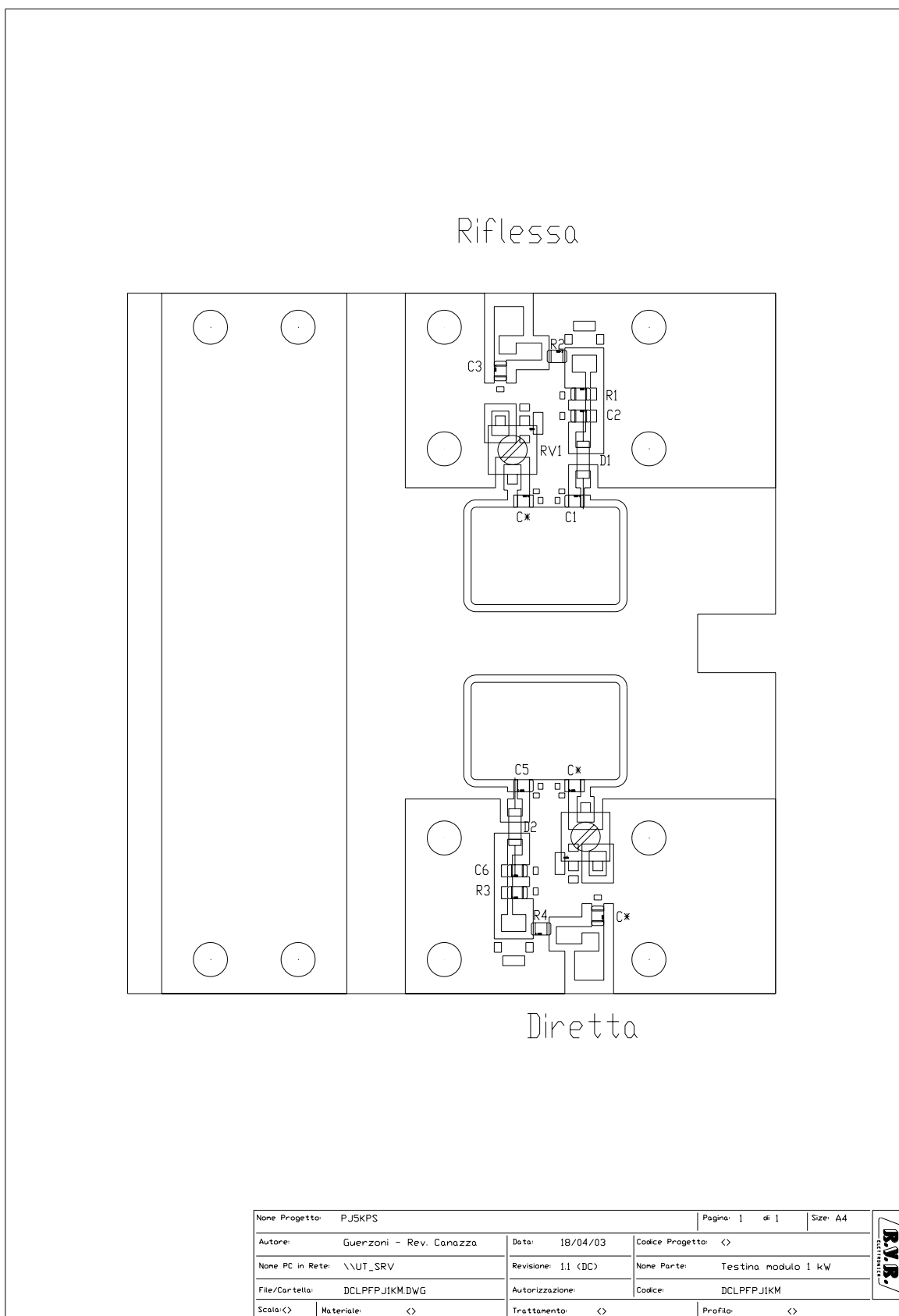

SCHEMA ELETTRICO

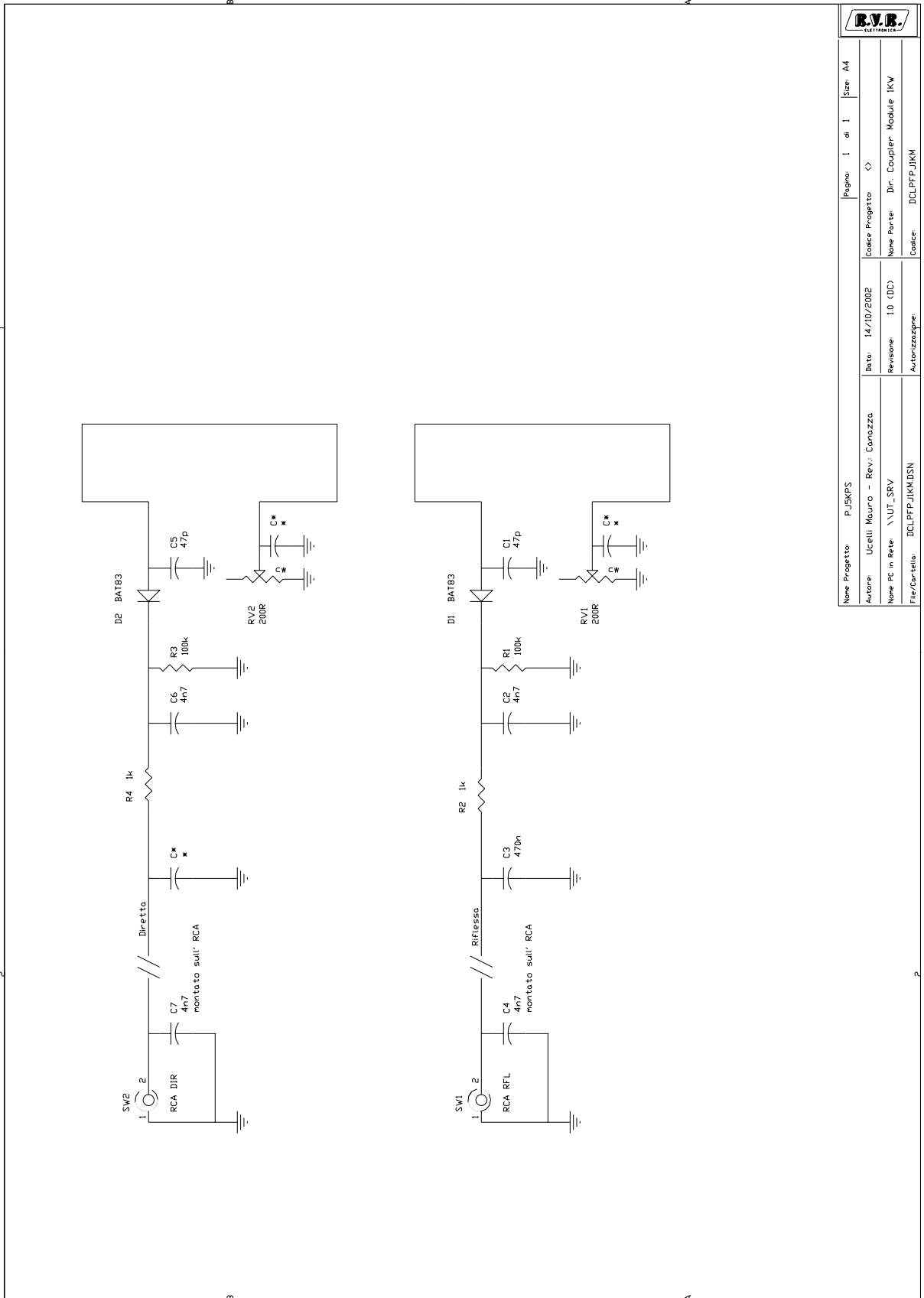

## LISTA MATERIALI

Item	Quantity	Reference	Part
1	1	C*	*
2	2	C5, C1	47p
3	4	C2, C4, C6, C7	4n7
4	1	C3	470n
5	2	D2, D1	BAT83
6	2	RV2, RV1	200R
7	2	R3, R1	100k
8	2	R2, R4	1k
9	1	SW1	RCA RFL
10	1	SW2	RCA DIR



# SCHEDA MISURE SPLITTER INGRESSO

SLSPLMEA5KW1

PIANO DI MONTAGGIO

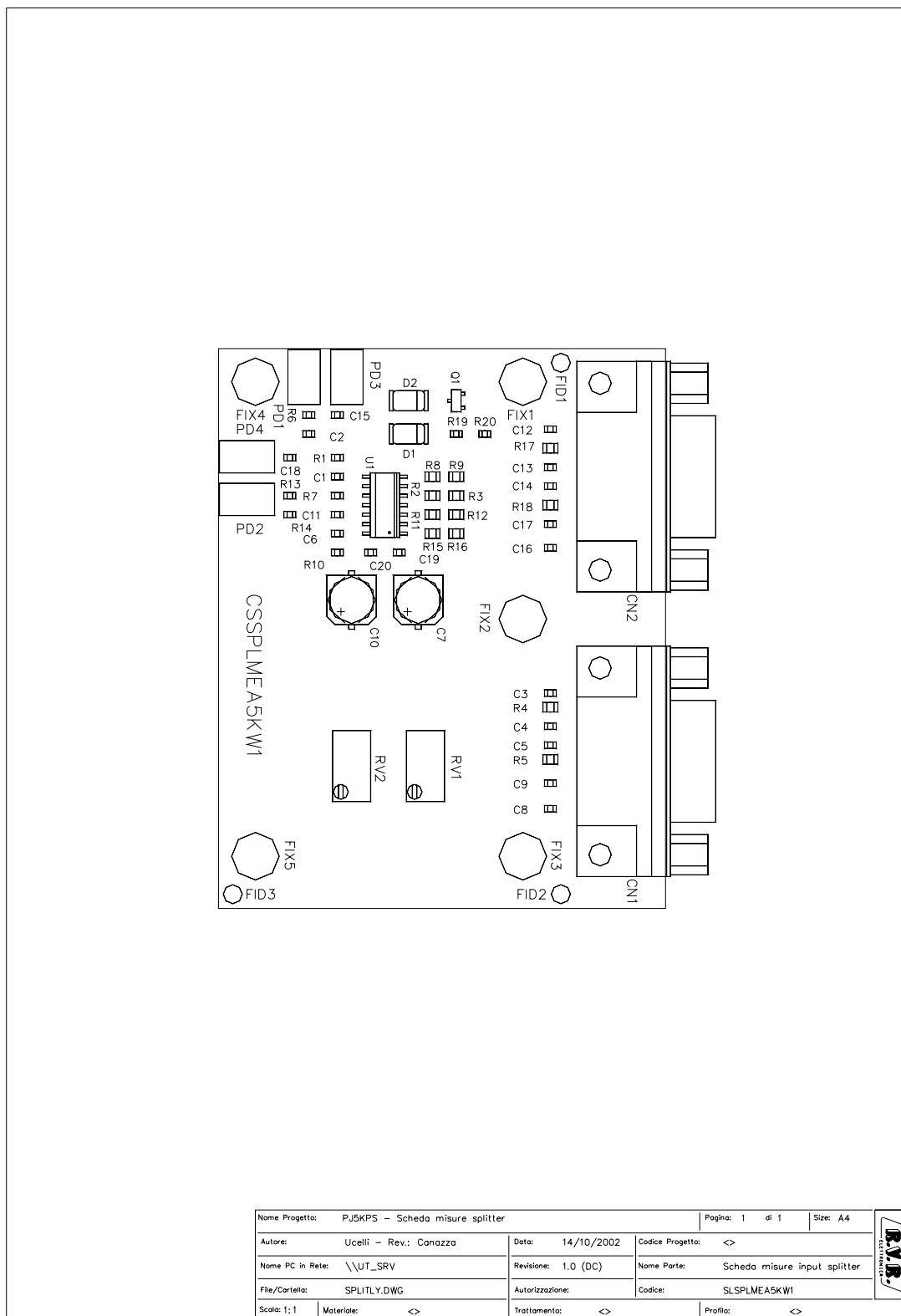

SCHEMA ELETTRICO

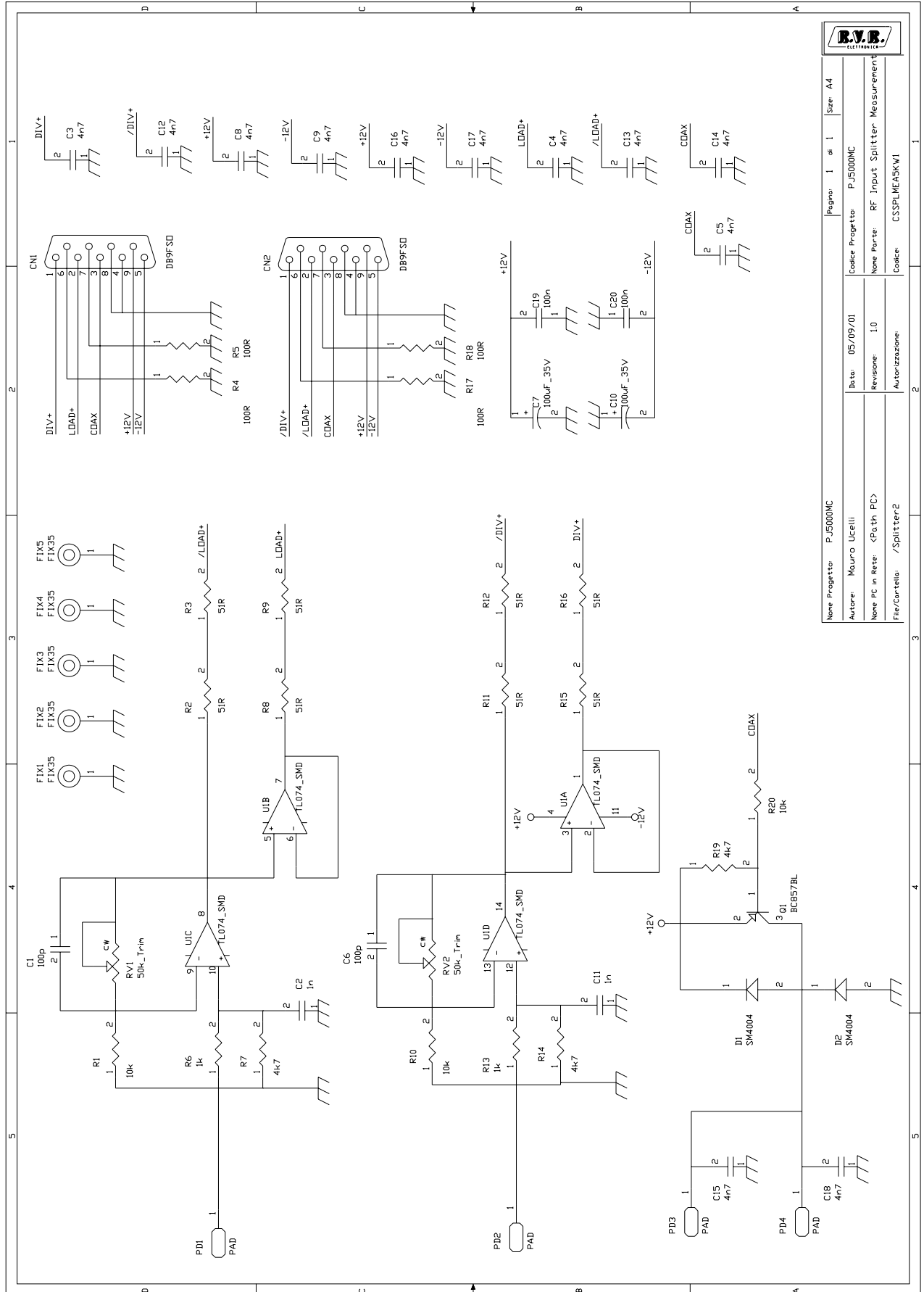

Nuovo Progetto: PJ5000MC Autore: Mauro Ucelli Nome PC in Rete: <Path PC> File/Cartella: /Splitter2	Pagina: 1 di 1 Size: A4 Codice Progetto: PJ5000MC Nome Parte: RF Input Splitter Measurement Codice: CSSPLMEASKV1
Data: 05/09/01 Revisione: 10 Autorizzazione:	

## LISTA MATERIALI

Item	Quantity	Reference	Part
1	2	CN2, CN1	DB9FSO
2	2	C6, C1	100p
3	2	C11, C2	1n
4	12	C3, C4, C5, C8, C9, C12, C13, C14, C15, C16, C17, C18	4n7
5	2	C7, C10	100uF 35V
6	2	C19, C20	100n
7	2	D1, D2	SM4004
8	5	FIX1, FIX2, FIX3, FIX4, FIX5	FIX35
9	4	PD1, PD2, PD3, PD4	PAD
10	1	Q1	BC857BL
11	2	RV2, RV1	50k Trim
12	3	R1, R10, R20	10k
13	8	R2, R3, R8, R9, R11, R12, R15, R16	51R
14	4	R4, R5, R17, R18	100R
15	2	R13, R6	1k
16	3	R7, R14, R19	4k7
17	1	U1	TL074 SMD

SPLITTER MODULO R.F.

SLSPLRFPJ5KM

PIANO DI MONTAGGIO

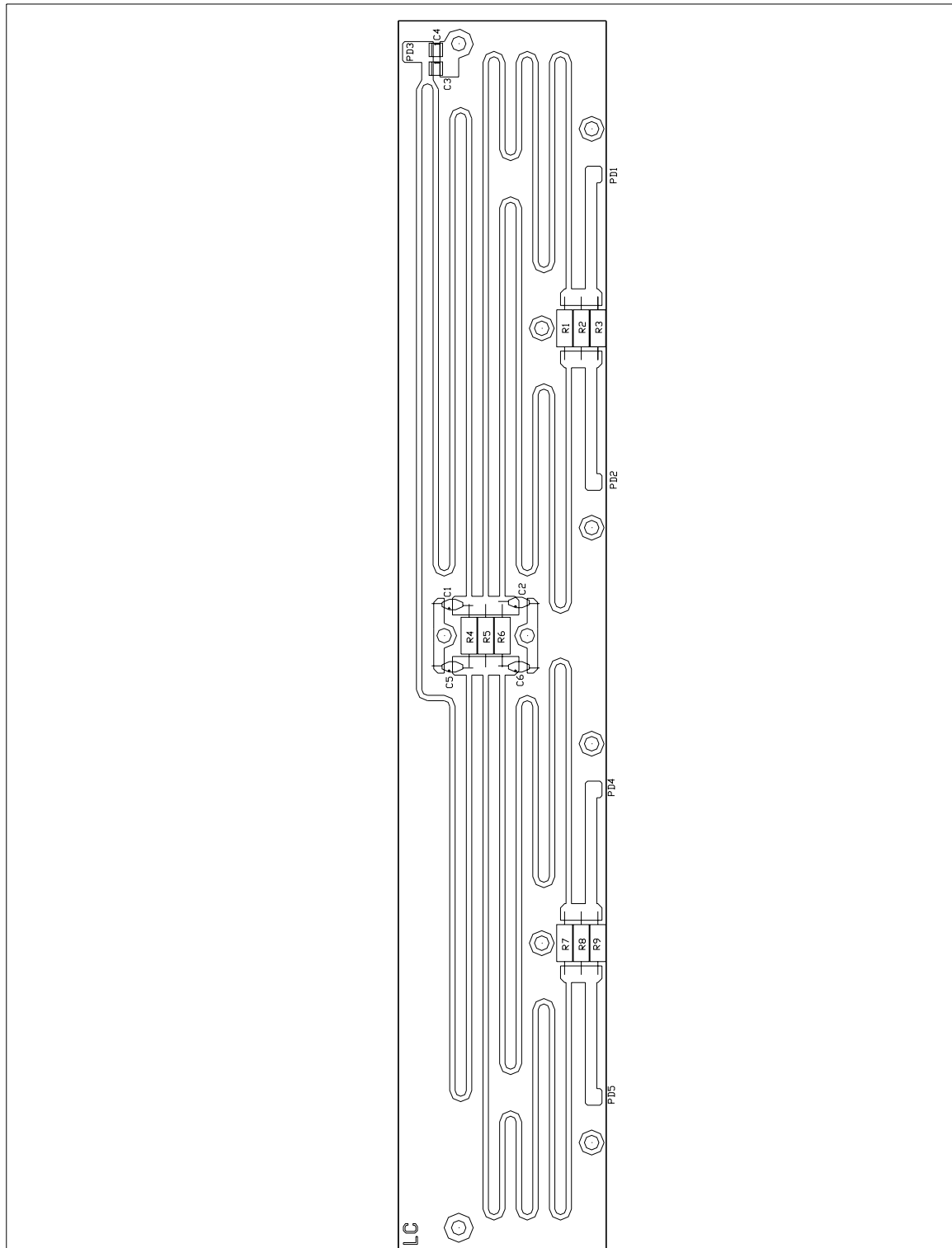

Nome Progetto: PJ5KPS - Modulo RF 1.2 kW		Pagina: 1 di 1	Size: A4
Autore: Ucelli - Rev. Canazza	Data: 09/10/2002	Codice Progetto: <>	
Nome PC in Rete: \\UT_SRV	Revisione: 1.0 (DC)	Nome Parte: Splitter	
File/Cartella: CSSPLRFPJ5KM.DWG	Autorizzazione:	Codice: SLSPLRFPJ5KM	
Scala:<>	Materiale: <>	Trattamento: <>	Profilo: <>



SCHEMA ELETTRICO

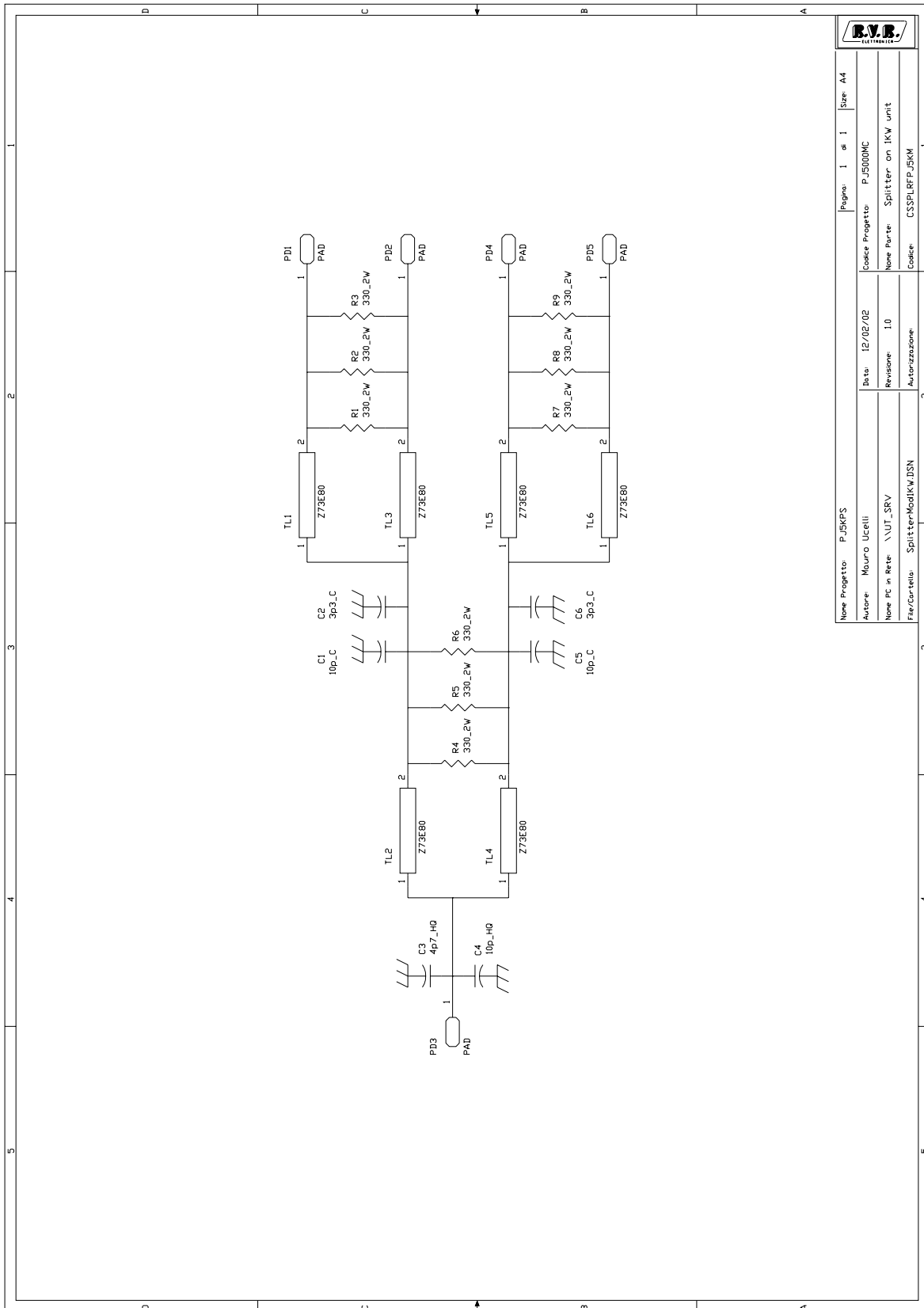

		Pagina 1 di 1 Size: A4	
Nome Progetto:	PJ5KPS	Codice Progetto:	PJ5000MC
Autore:	MaurO Ucelli	Data:	12/02/02
Nome FC in Rete:	\\UT_SRV	Revisione:	10
File/Cartella:	SplitterModKW.DSN	Nome Parte:	Splitter on KW unit
		Codice:	CSSPLRFPJ5KM
		AutORIZZAZIONE:	

## LISTA MATERIALI

Item	Quantity	Reference	Part
2	2	C6, C2	3p3 C
3	1	C3	4p7 HQ
4	1	C4	10p HQ
5	5	PD1, PD2, PD3, PD4, PD5	PAD
6	9	R1, R2, R3, R4, R5, R6, R7, R8, R9	330 2W
7	6	TL1, TL2, TL3, TL4, TL5, TL6	Z73E80

SCHEDA FUSIBILI MODULO R.F.

SLFUSRFPJ5KM

PIANO DI MONTAGGIO

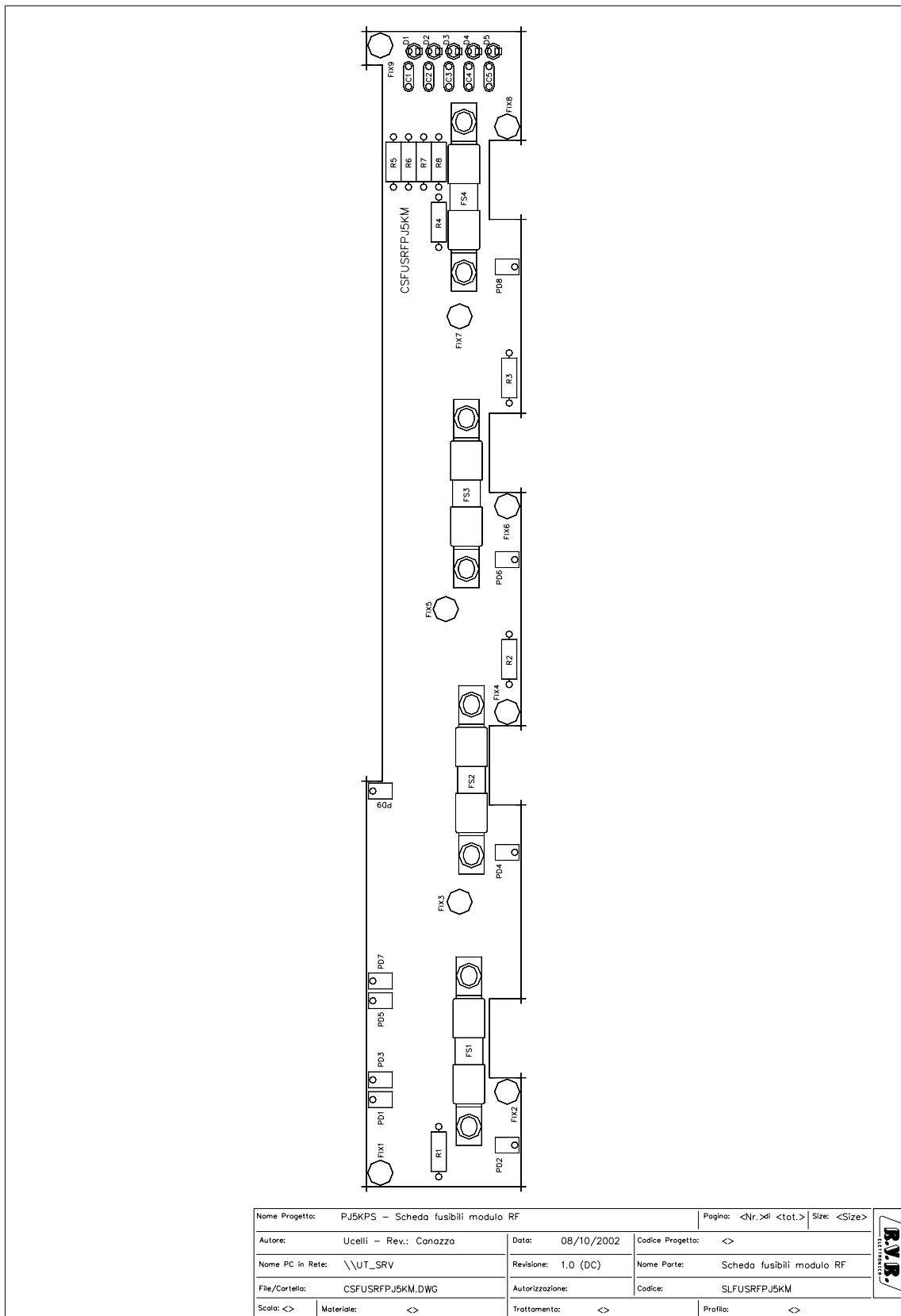

Nome Progetto: PJ5KPS - Scheda fusibili modulo RF		Pagina: <Nr.>di <tot.>	Size: <Size>
Autore: Ucelli - Rev.: Canazza		Data: 08/10/2002	Codice Progetto: <>
Nome PC in Rete: \\UT_SRV		Revisione: 1.0 (DC)	Nome Parte: Scheda fusibili modulo RF
File/Cartella: CSFUSRFPJ5KM.DWG		Autorizzazione:	Codice: SLFUSRFPJ5KM
Scala: <>	Materiale: <>	Trattamento: <>	Profilo: <>



SCHEMA ELETTRICO

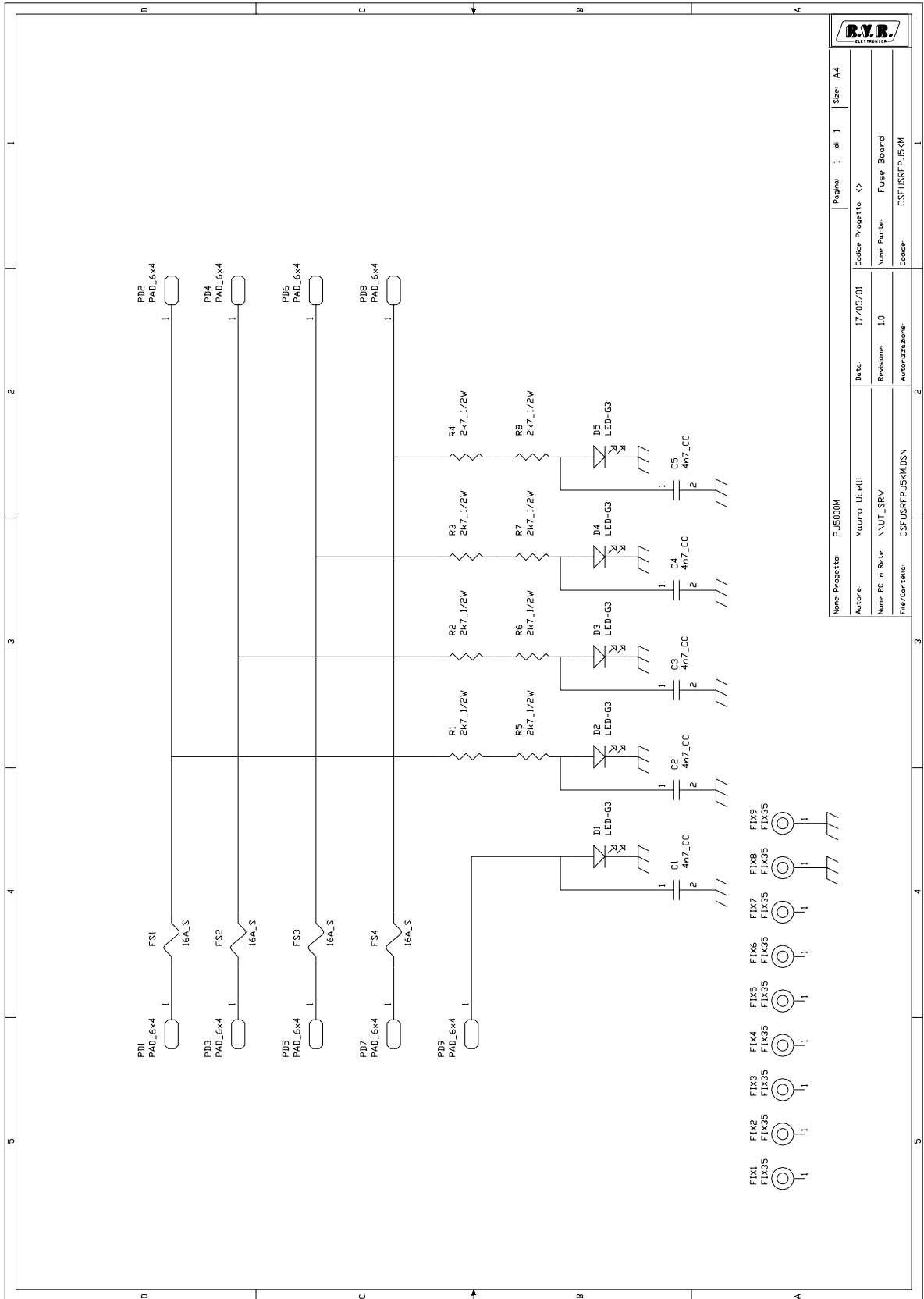

		Pagina: 1 di 1 Size: A4
Nome Progetto: PJ10KPS-C	Data: 17/05/01	Codice Progetto: <>
Autore: Mauro Ucelli	Revisione: 1.0	Nome Parte: Fuse Board
Nome PC in Rete: \AUT_SRV	Autorizzazione:	Codice: CSFUSRFPJ5KM
File/Cartella: CSFUSRFPJ5KM\DSN		



## LISTA MATERIALI

Item	Quantity	Reference	Part
1	5	C1, C2, C3, C4, C5	4n7 CC
2	5	D1, D2, D3, D4, D5	LED-G3
3	9	FIX1, FIX2, FIX3, FIX4, FIX5, FIX6, FIX7, FIX8, FIX9	FIX35
4	4	FS1, FS2, FS3, FS4	16A S
5	9	PD1, PD2, PD3, PD4, PD5, PD6, PD7, PD8, PD9	PAD_6x4
6	8	R1, R2, R3, R4, R5, R6, R7, R8	2k7 1/2W

SCHEDA MISURA SBILANCIAMENTO

SLPWRSEHC52

PIANO DI MONTAGGIO

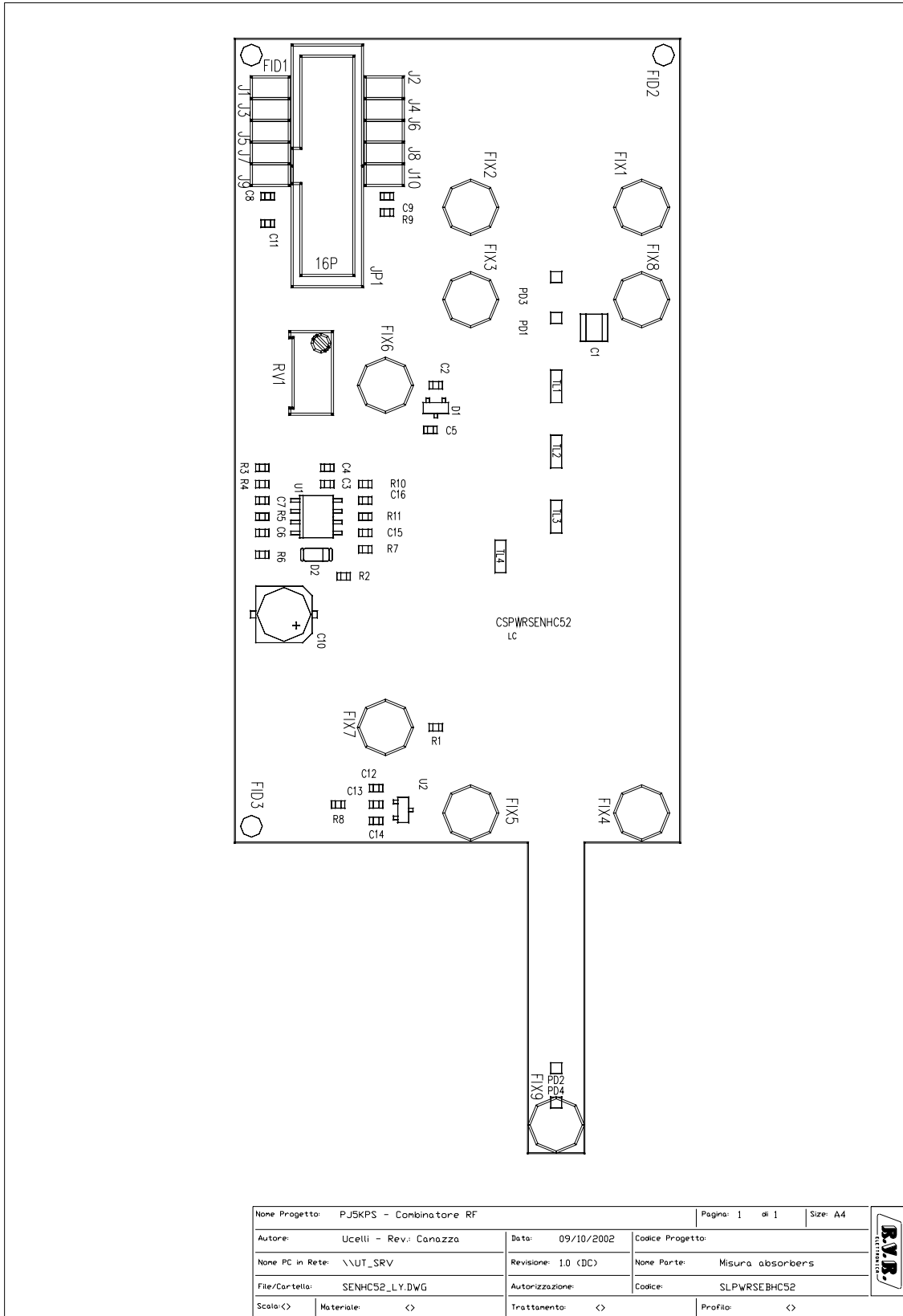

Nome Progetto: PJ5KPS - Combinatore RF		Pagina: 1 di 1	Size: A4
Autore: Ucelli - Rev.: Canazza		Data: 09/10/2002	Codice Progetto:
None PC in Rete: \\UT_SRV		Revisione: 1.0 (DC)	Nome Parte: Misura absorbers
File/Cartella: SENHCS2_LY.DWG		Autorizzazione:	Codice: SLPWRSEHC52
Scala: <	Materiale: <	Trattamento: <	Profilo: <



SCHEMA ELETTRICO

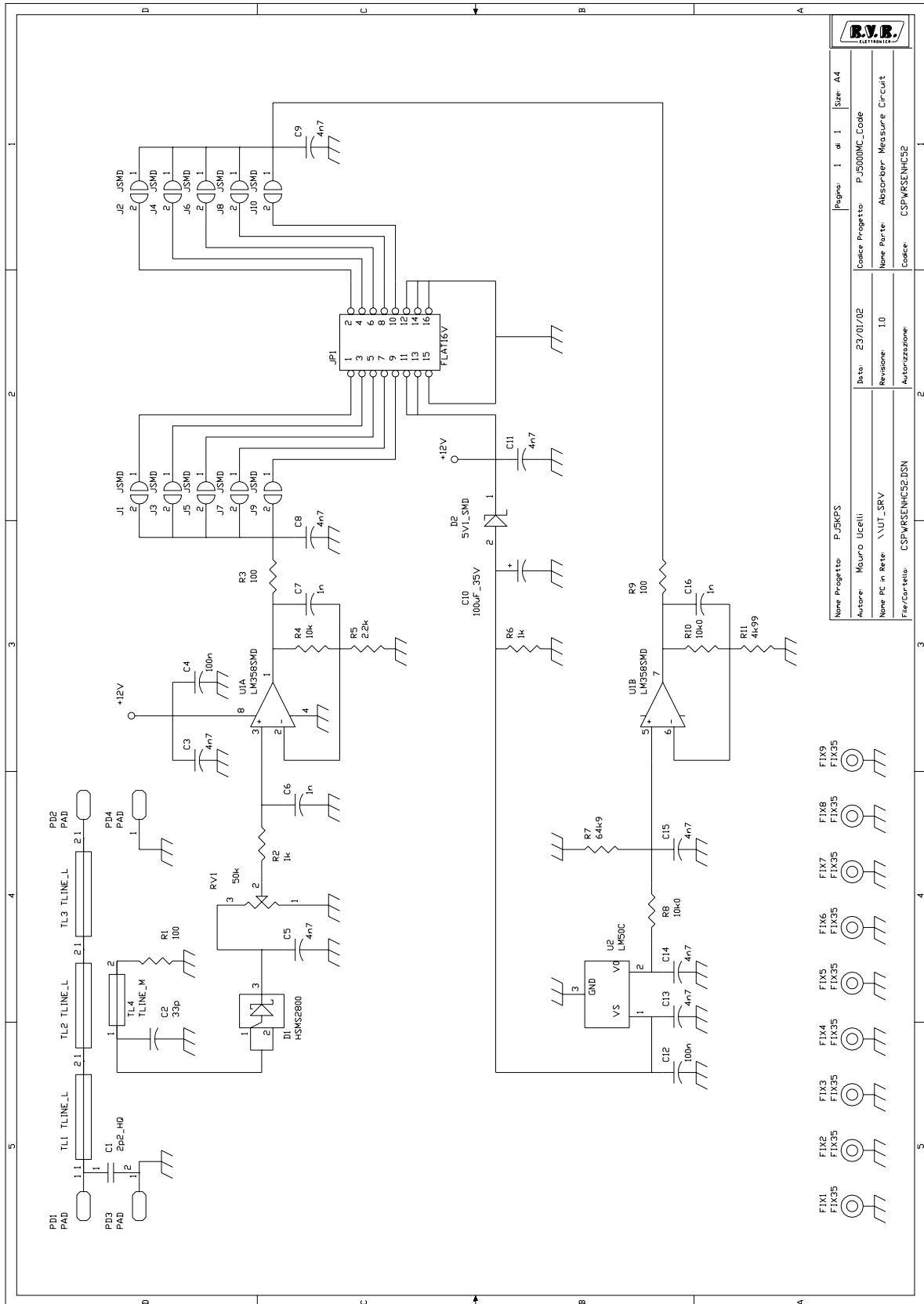

Nome Progetto	PJ5KPS
Autore	Maurizio Ucelli
Nome PC in Rete	\\U1_SRV
File/Cartella	CSPARSENHCSE\DSN
Coste Progetto	PJ5000MC_Code
Nome Parte	Absorber_Measure_Circuit
Revisione	1.0
Autore/Revisione	CSPARSENHCSE
Page	1 of 1
Size	A4
Date	23/01/02

- FIX1 FIX35
- FIX2 FIX35
- FIX3 FIX35
- FIX4 FIX35
- FIX5 FIX35
- FIX6 FIX35
- FIX7 FIX35
- FIX8 FIX35
- FIX9 FIX35

## LISTA MATERIALI

Item	Quantity	Reference	Part
1	1	C1	2p2 HQ
2	1	C2	33p
3	8	C3, C5, C8, C9, C11, C13, C14, C15	4n7
4	2	C12, C4	100n
5	3	C6, C7, C16	1n
6	1	C10	100uF 35V
7	1	D1	HSMS2800
8	1	D2	5V1 SMD
9	9	FIX1, FIX2, FIX3, FIX4, FIX5, FIX6, FIX7, FIX8, FIX9	FIX35
10	1	JP1	FLAT16V
11	10	J1, J2, J3, J4, J5, J6, J7, J8, J9, J10	JSMD
12	4	PD1, PD2, PD3, PD4	PAD
13	1	RV1	50k
14	3	R1, R3, R9	100
15	2	R6, R2	1k
16	1	R4	10k
17	1	R5	2.2k
18	1	R7	64k9
19	2	R8, R10	10k0
20	1	R11	4k99
21	3	TL1, TL2, TL3	TLINE L
22	1	TL4	TLINE M
23	1	U1	LM358SMD
24	1	U2	LM50C

SELETTORE MISURA ANALOGICA

SLMETPJ5KM4

PIANO DI MONTAGGIO

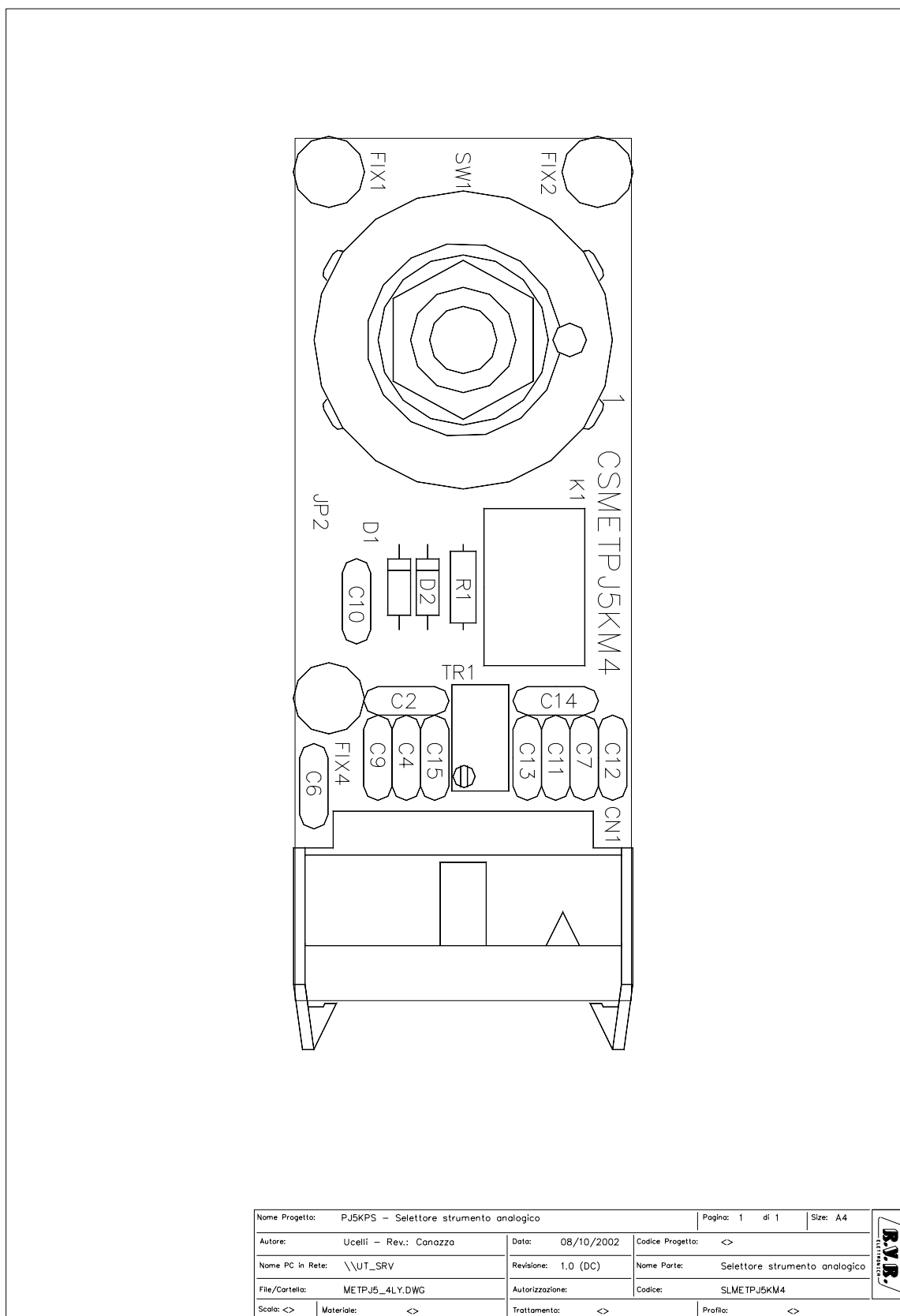

Nome Progetto: PJ5KPS - Selettore strumento analogico		Pagina: 1 di 1	Size: A4
Autore: Ucelli - Rev.: Canazza		Data: 08/10/2002	Codice Progetto: <>
Nome PC in Rete: \\UT_SRV		Revisione: 1.0 (DC)	Nome Parte: Selettore strumento analogico
File/Cartella: METPJ5_4LY.DWG		Autorizzazione:	Codice: SLMETPJ5KM4
Scala: <>	Materiale: <>	Trattamento: <>	Profilo: <>



SCHEMA ELETTRICO

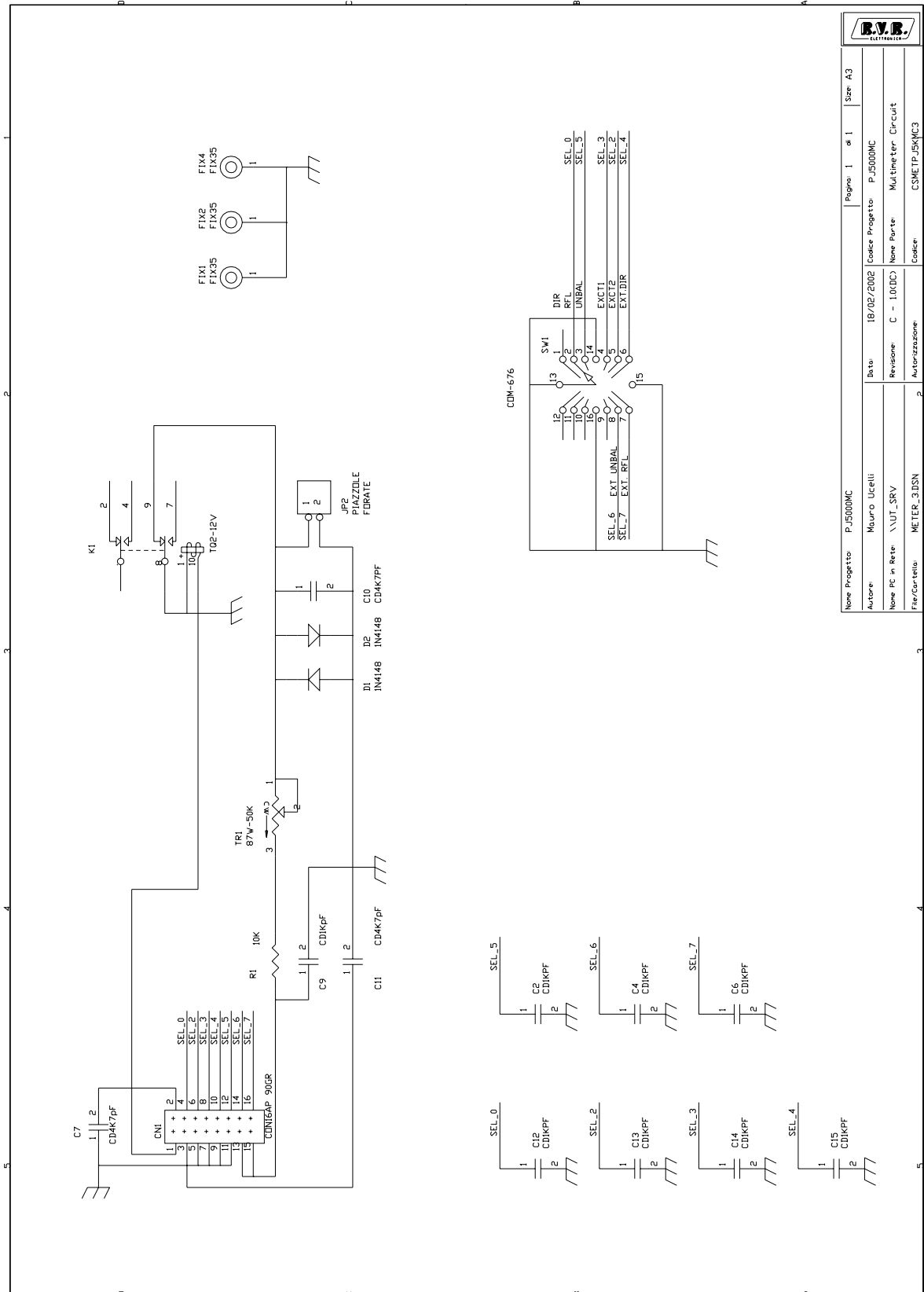

Nome Progetto: P_J5000MC		Pagina: 1 di 1		Size: A3	
Autore: Mauro Ucelli		Data: 18/02/2002		Codice Progetto: P_J5000MC	
Nome PC in Rete: \\UT_SRV		Revisione: C - 1.0(0C)		Nome Porte: Multimeter Circuit	
File/Cartella: METER_3.DSN		Autorizzazione:		Codice: CSNETPJSKMC3	

## LISTA MATERIALI

Item	Quantity	Reference	Part
1	1	CN1	CON16AP 90GR
2	8	C2, C4, C6, C9, C12, C13, C14, C15	CD1KPF
3	3	C7, C10, C11	CD4K7pF
4	2	D1, D2	1N4148
5	3	FIX1, FIX2, FIX4	FIX35
6	1	JP2	PIAZZOLE
7	1	K1	TQ2-12V
8	1	R1	10K
9	1	SW1	COM-676
10	1	TR1	87W-50K

**INTERFACCIA I/O MODULO R.F.**

SLIORFPJ5KM2

PIANO DI MONTAGGIO

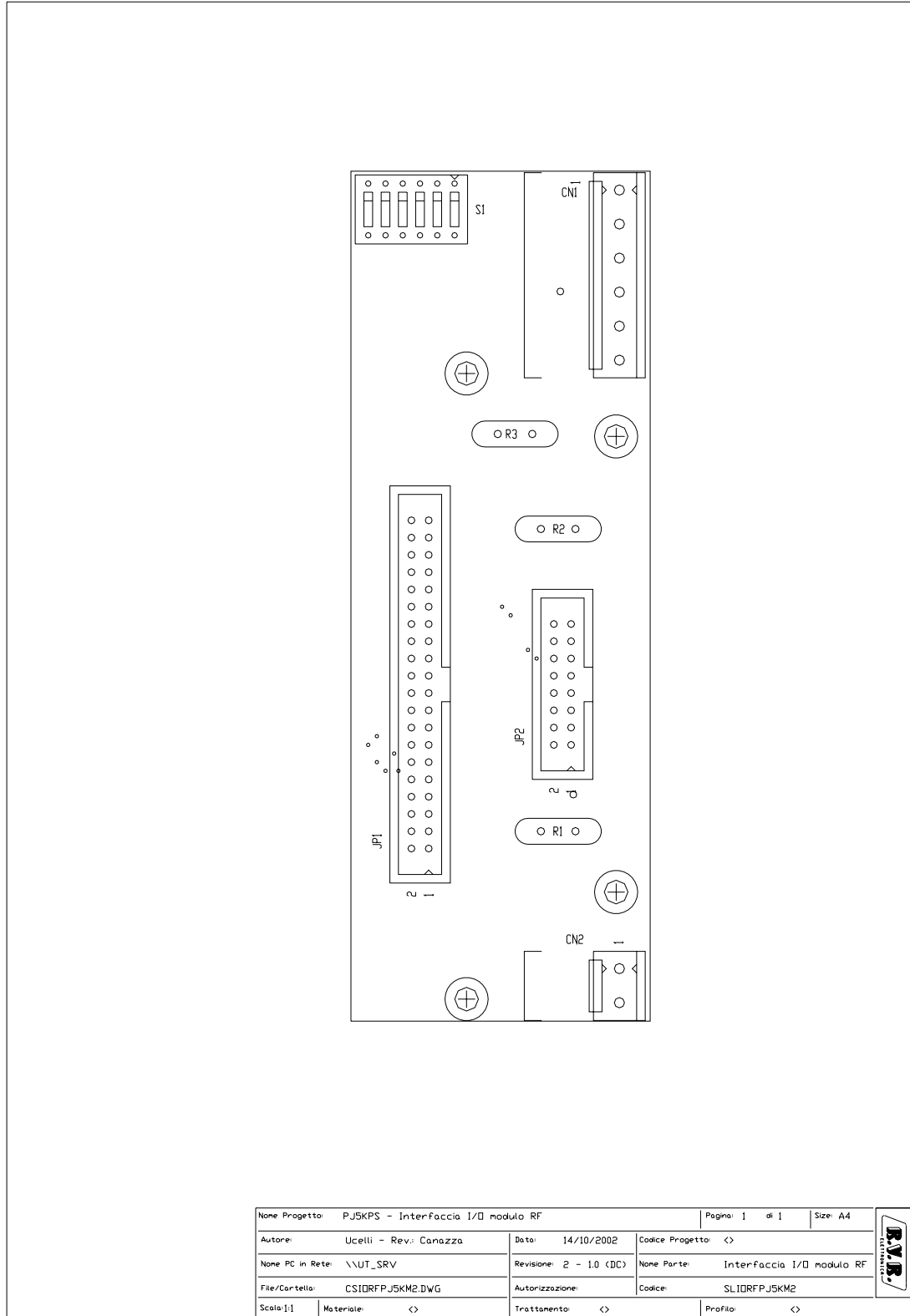

Nome Progetto: PJ5KPS - Interfaccia I/O modulo RF		Pagina: 1 di 1	Size: A4
Autore: Ucelli - Rev.: Canazza	Data: 14/10/2002	Codice Progetto: <>	
Nome PC in Rete: \\UT_SRV	Revisione: 2 - 1.0 (DC)	Nome Parte: Interfaccia I/O modulo RF	
File/Cartella: CSIORFPJ5KM2.DWG	Autorizzazione:	Codice: SLIORFPJ5KM2	
Scala: 1:1	Materiale: <>	Trattamento: <>	Profilo: <>





SCHEMA ELETTRICO

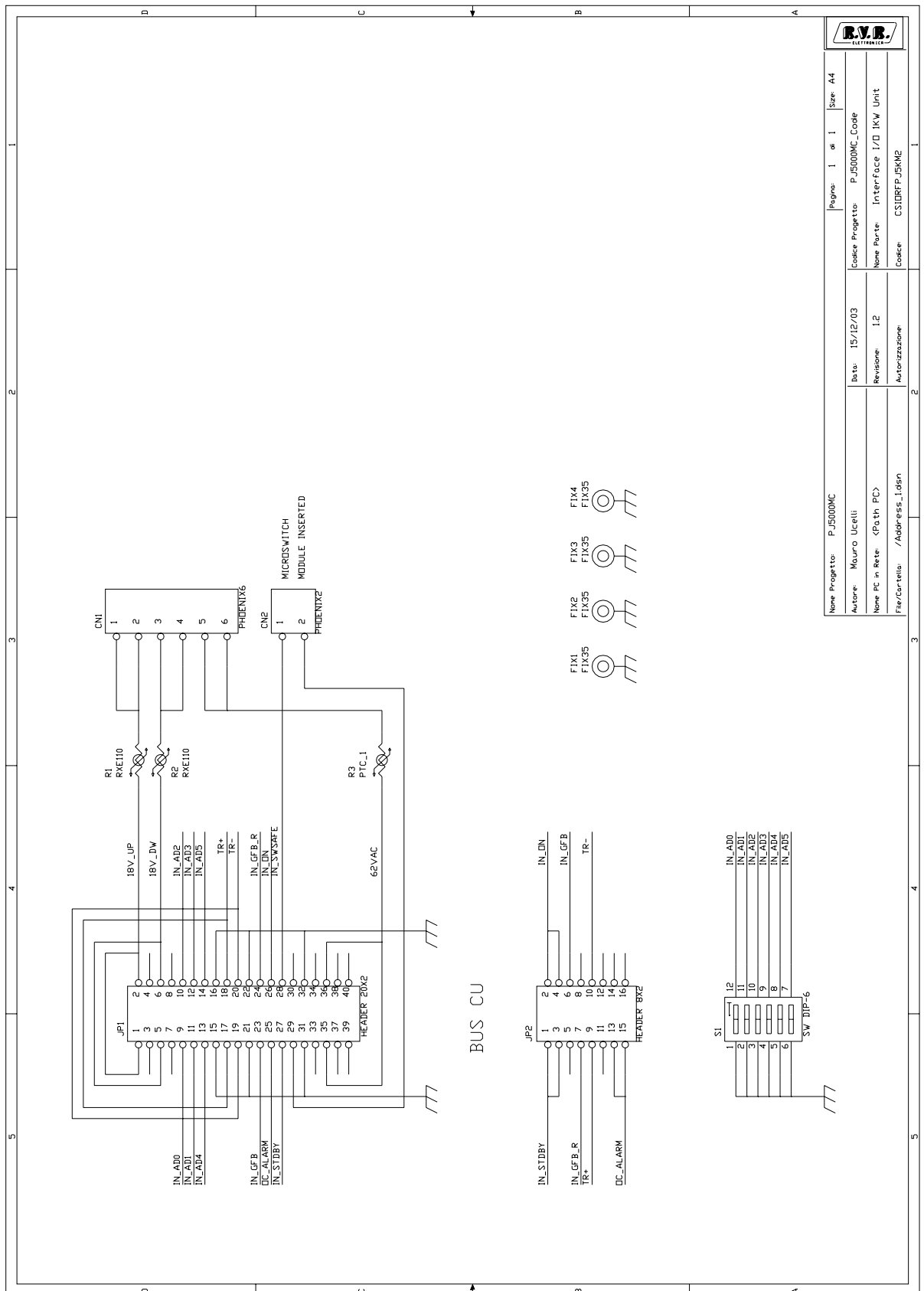

		Pagina: 1 di 1 Size: A4
Nome Progetto: PJ5000MC	Codice Progetto: PJ5000MC_Code	Data: 15/12/03
Autore: Mauro Ucelli	Nome Parte: Interface I/O IKW Unit	Revisione: 1.2
Nome PC in Rete: <Path PC>	File/Cartella: /Address_1.dsn	Autorizzazione:
Nome Progetto: PJ5000MC	Codice Progetto: PJ5000MC_Code	Size: A4
Autore: Mauro Ucelli	Nome Parte: Interface I/O IKW Unit	Revisione: 1.2
Nome PC in Rete: <Path PC>	File/Cartella: /Address_1.dsn	Autorizzazione:

## Lista Materiali

Item	Quantity	Reference	Part
1			
2	1	CN1	PHOENIX6
3	1	CN2	PHOENIX2
4	4	FIX1, FIX2, FIX3, FIX4	FIX35
5	1	JP1	HEADER 20X2
6	1	JP2	HEADER 8X2
7	2	R2, R1	RXE110
8	1	R3	PTC 1
9	1	S1	SW DIP-6

# ACCOPIATORE DIREZIONALE DI USCITA

SLPWRMTRHC51

## PIANO DI MONTAGGIO

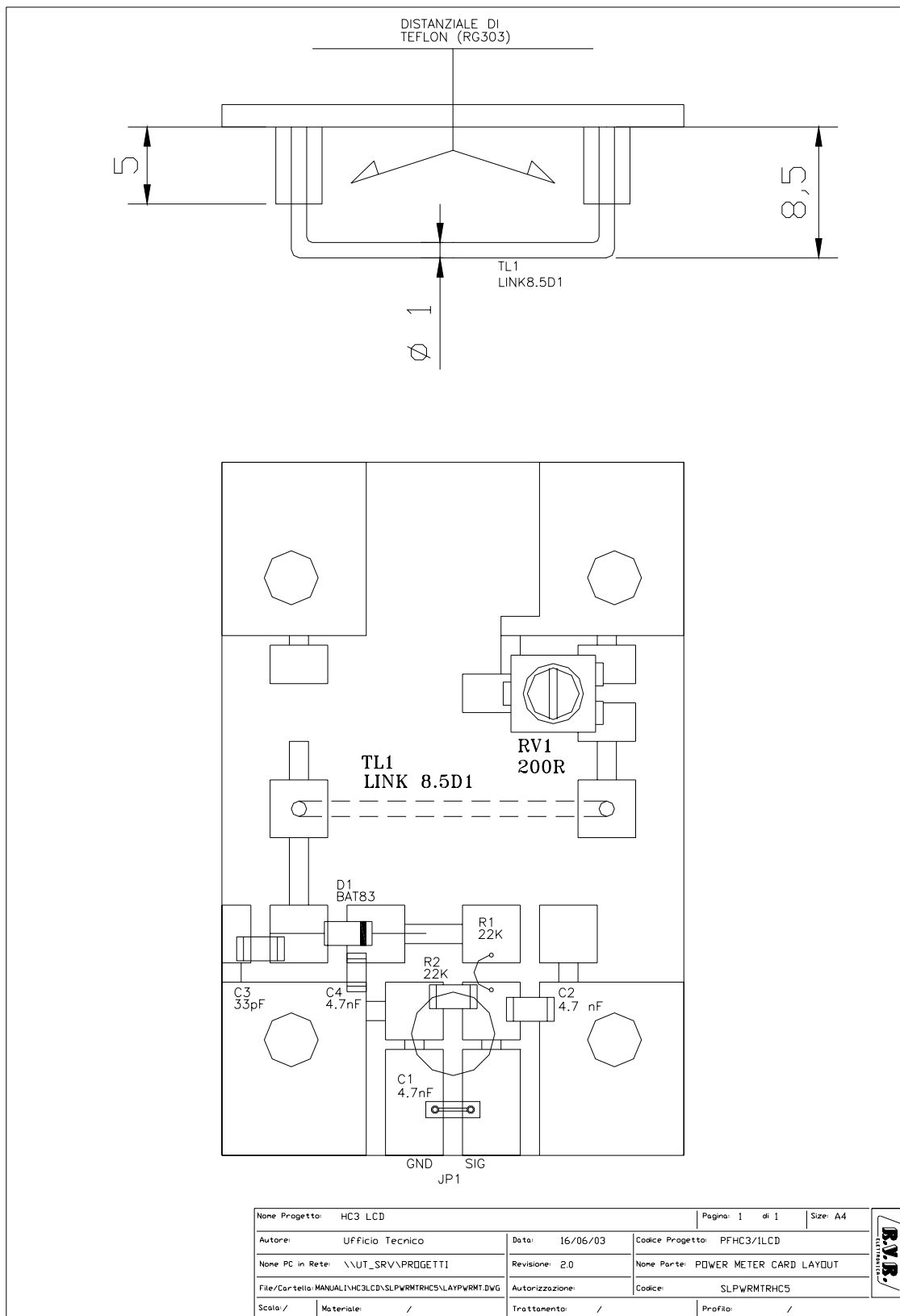

Nome Progetto: HC3 LCD		Pagina: 1 di 1	Size: A4
Autore: Ufficio Tecnico	Data: 16/06/03	Codice Progetto: PFHC3/ILCD	
Nome PC in Rete: \\UT_SRV\PROGETTI	Revisione: 2.0	Nome Parte: POWER METER CARD LAYOUT	
File/Cortello: MANUAL\HC3LCD\SLPWRMTRHC5\LAYPWRMT.DWG	Autorizzazione:	Codice: SLPWRMTRHC5	
Scala: /	Materiale: /	Trattamento: /	Profilo: /



SCHEMA ELETTRICO

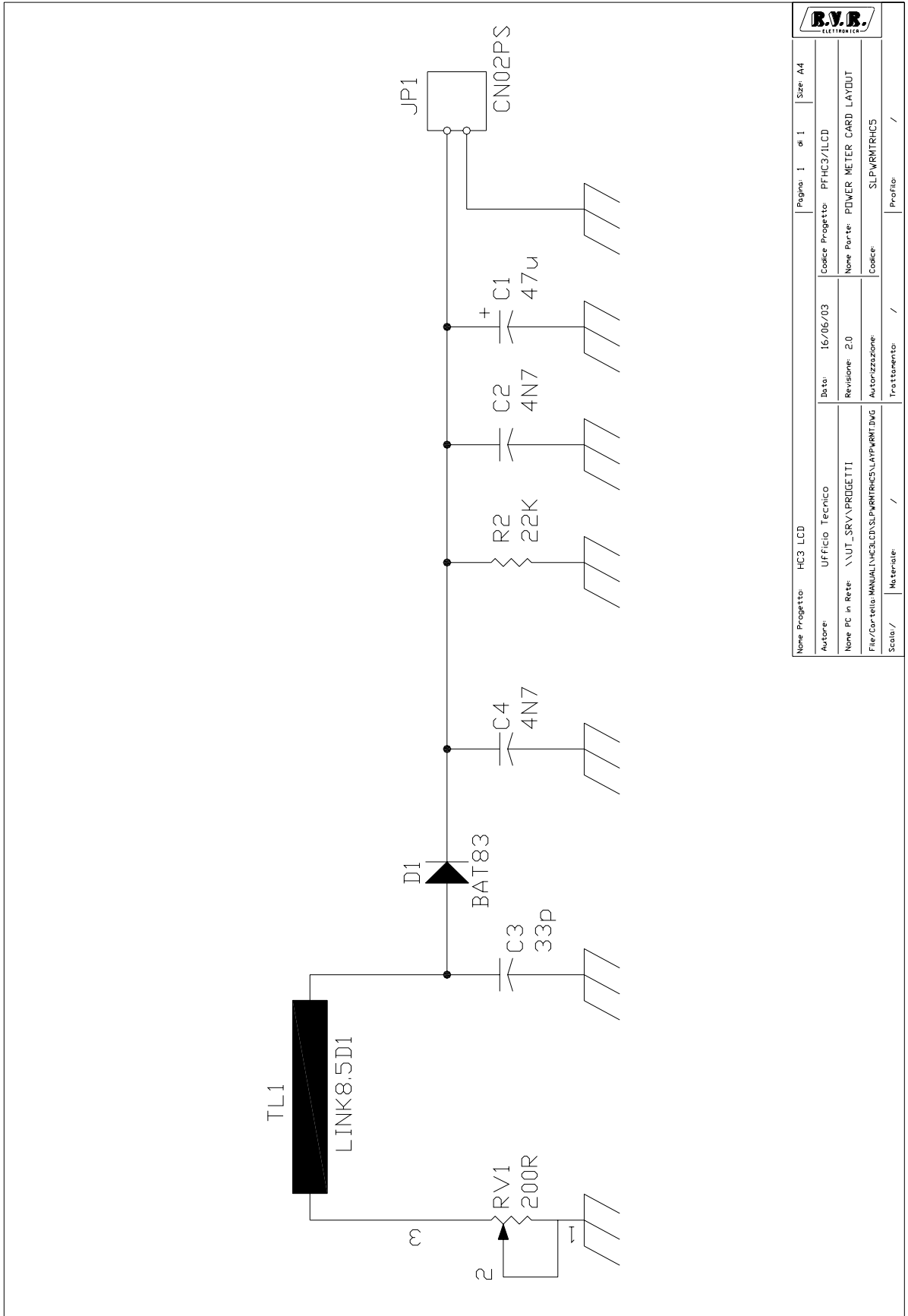

Nome Progetto: HC3 LCD		Pagina: 1	di 1	Size: A4
Autore:	UFFICIO Tecnico	Data:	16/06/03	Codice Progetto: PFHC3/LCD
Nome PC in Rete:	\\UT_SRV\PROGETTI	Revisione:	2.0	Nome Parte: POWER METER CARD LAYOUT
File/Carrello:	MANUAL\HC3LCD\SLP\WRMTRHC5\LAY\PMTR.DWG	Autorizzazione:		Codice: SLP\WRMTRHC5
Scala:	Materiali: /	Trattamento:	/	Profilo: /

## LISTA MATERIALI

Item	Quantity	Reference	Part
1	1	C1	47u
2	2	C4, C2	4n7
3	1	C3	33p
4	1	D1	BAT 83
5	1	JP1	CN02PS
6	1	RV1	200R
7	2	R2	22k
8	1	TL1	LINK8.5D1

# INTERFACCIA RELÉ DI POTENZA

## SLRLYCPROTVJ

### PIANO DI MONTAGGIO

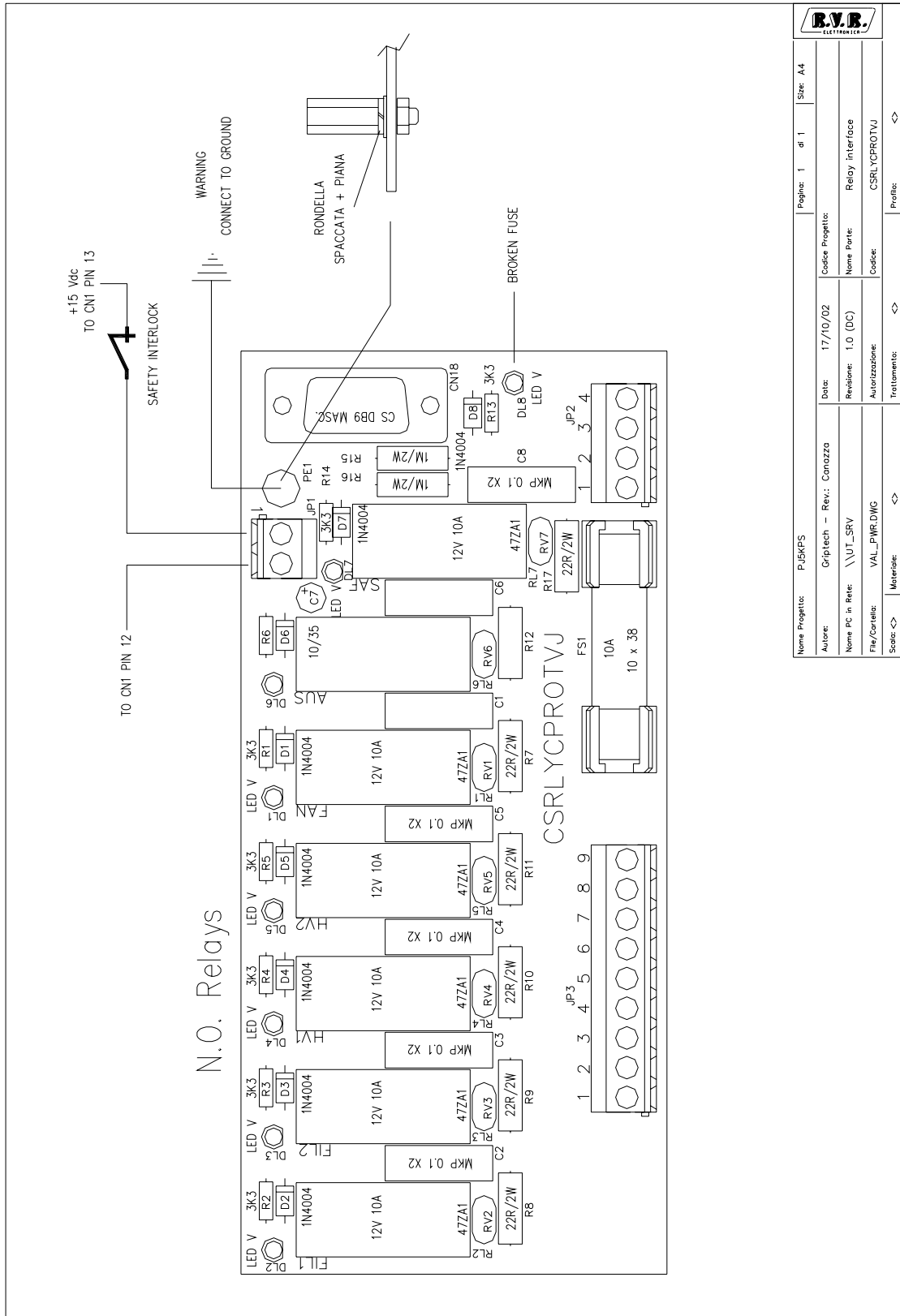

		Pagina: 1 di 1 Size: A4
Nome Progetto: PJ5KPS	Codice Progetto:	Data: 17/10/02
Autore: CripTech - Rev.: Canozza	Nome Parte: Relay Interface	Revisione: 1.0 (DC)
Nome PC in Rete: \\UT_SRV	Autorizzazione:	Codice: CSRLYCPROTVJ
File/Caricelli: VAL_PWR.DWG	Materiale:	Trattamento:
Scaric: <->	Profilo:	<->

SCHEMA ELETTRICO

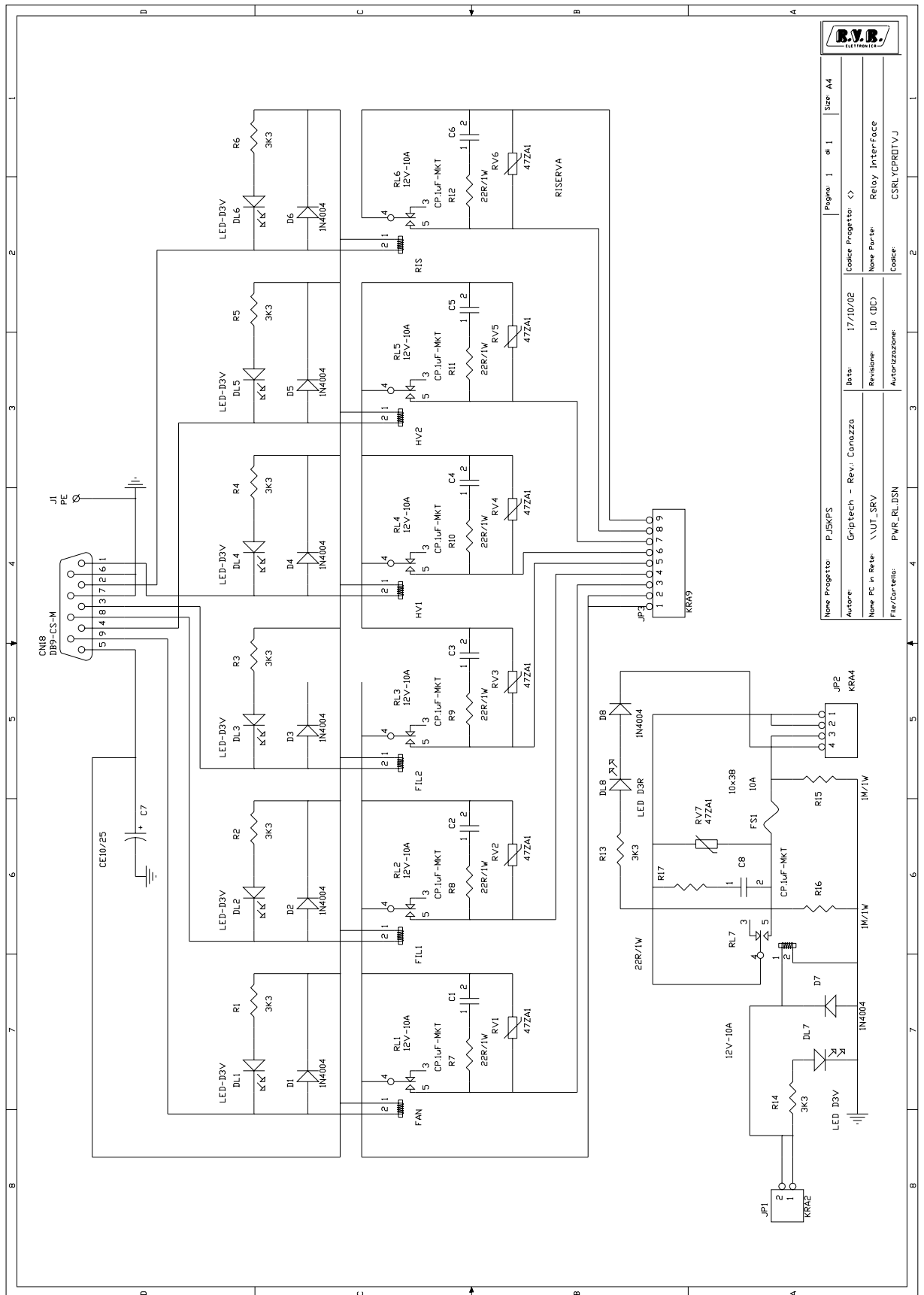

## LISTA MATERIALI

Item	Quantity	Reference	Part
1	1	CN18	DB9-CS-M
2	7	C1, C2, C3, C4, C5, C6, C8	CP.1uF-MKT
3	1	C7	CE10/25
4	6	DL1, DL2, DL3, DL4, DL5, DL6	LED-D3V
5	1	DL7	LED D3V
6	1	DL8	LED D3R
7	8	D1, D2, D3, D4, D5, D6, D7, D8	1N4004
8	1	FS1	10x38
9	1	JP1	KRA2
10	1	JP2	KRA4
11	1	JP3	KRA9
12	1	J1	PE
13	7	RL1, RL2, RL3, RL4, RL5, RL6, RL7	12V-10A
14	7	RV1, RV2, RV3, RV4, RV5, RV6, RV7	47ZA1
15	8	R1, R2, R3, R4, R5, R6, R13, R14	3K3
16	7	R7, R8, R9, R10, R11, R12, R17	22R/1W
17	2	R15, R16	1M/1W



**SCHEDA EMERGENZA CCU**

SLCCUEMPJ5K2

PIANO DI MONTAGGIO

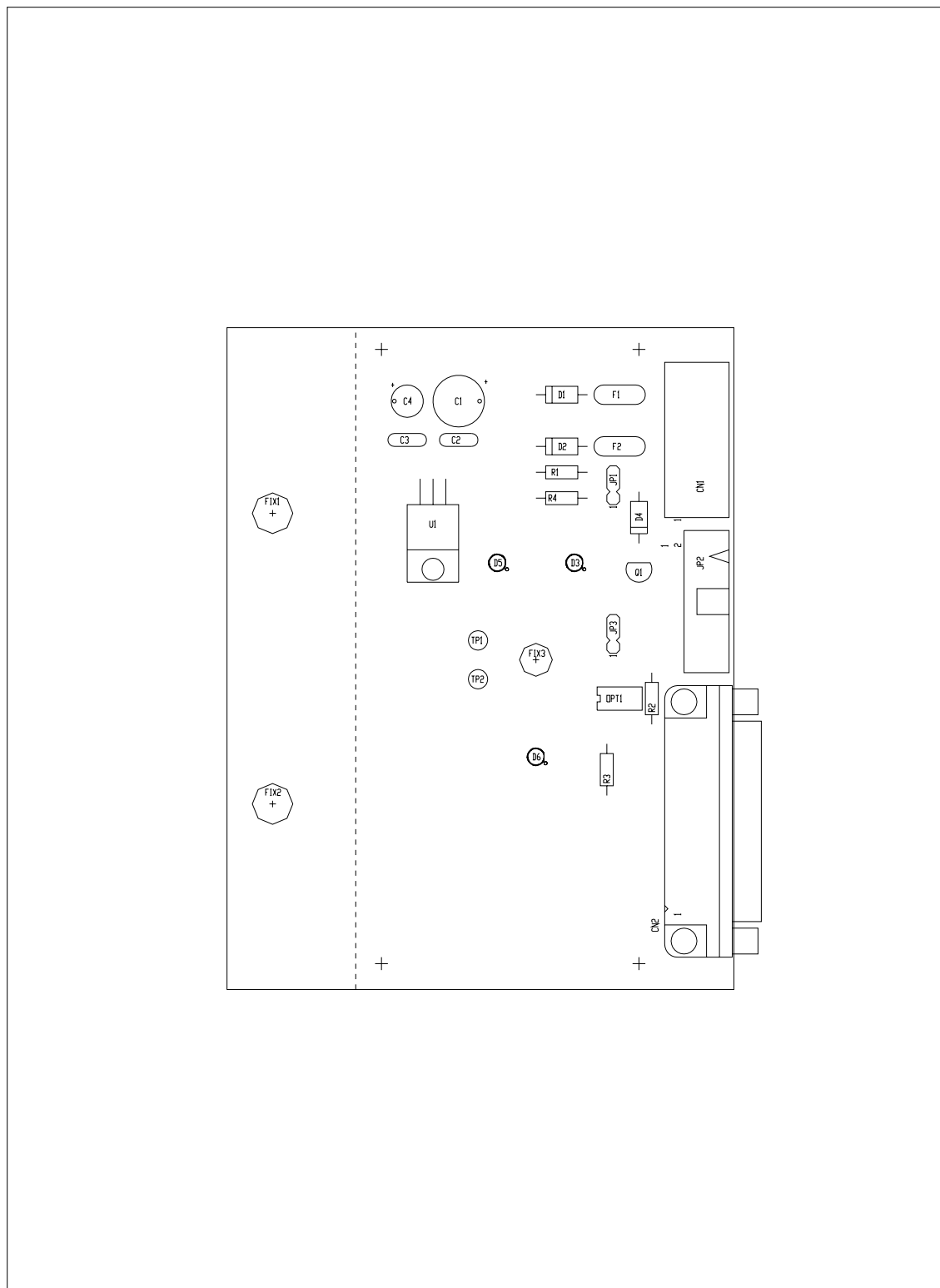

	NOME PROGETTO	PJ10KPS	NOME PARCHEDA EMERGENZA CCU PJ5K
	AUTORE:	Poluzzi S.	DATA 07/03/2005 REVISIONE 2:0 SCALA: 1 SIZE: A4 PAGINA 1 DI 1
ARCHIVIAZIONE ELETTRONICA PROGETTI SU "CORSO" PROGETTO:		CODICE DISEGNO SLCCUEMPJ5K2	
MATERIALI 4-74 1.6mm Cu 35FRATTAMEN	SO	STANDARD COSTRUTTORE	PROFILO/ STATO/

SCHEMA ELETTRICO

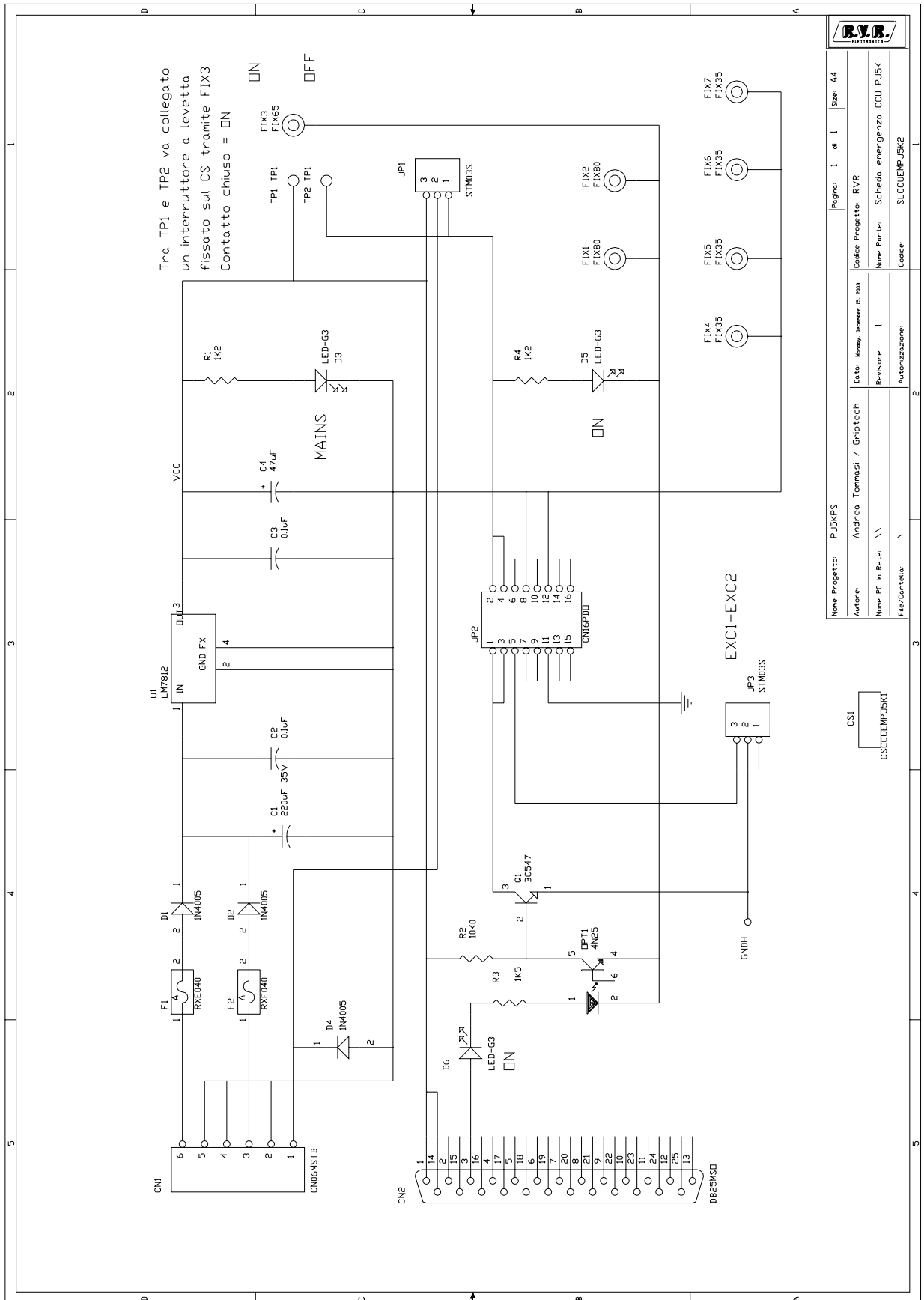

## LISTA MATERIALI

Item	Quantity	Reference	Part
1	1	CN1	CN06MSTB
2	1	CN2	DB25MSO
3	1	CS1	CSCCUEMPJ5K1
4	1	C1	220uF 35V
5	2	C2, C3	0.1uF
6	1	C4	47uF
7	3	D1, D2, D4	1N4005
8	3	D3, D5, D6	LED-G3
9	2	FIX1, FIX2	FIX80
10	1	FIX3	FIX65
11	4	FIX4, FIX5, FIX6, FIX7	FIX35
12	2	F1, F2	RXE040
13	2	JP3, JP1	STM03S
14	1	JP2	CN16PDO
15	1	OPT1	4N25
16	1	Q1	BC547
17	2	R4, R1	1K2
18	1	R2	10K0
19	1	R3	1K5
20	2	TP1, TP2	TP1
21	1	U1	LM7812

**SCHEDA MICROCONTROLLORE**

SLCPUPJ5KM2

**PIANO DI MONTAGGIO**

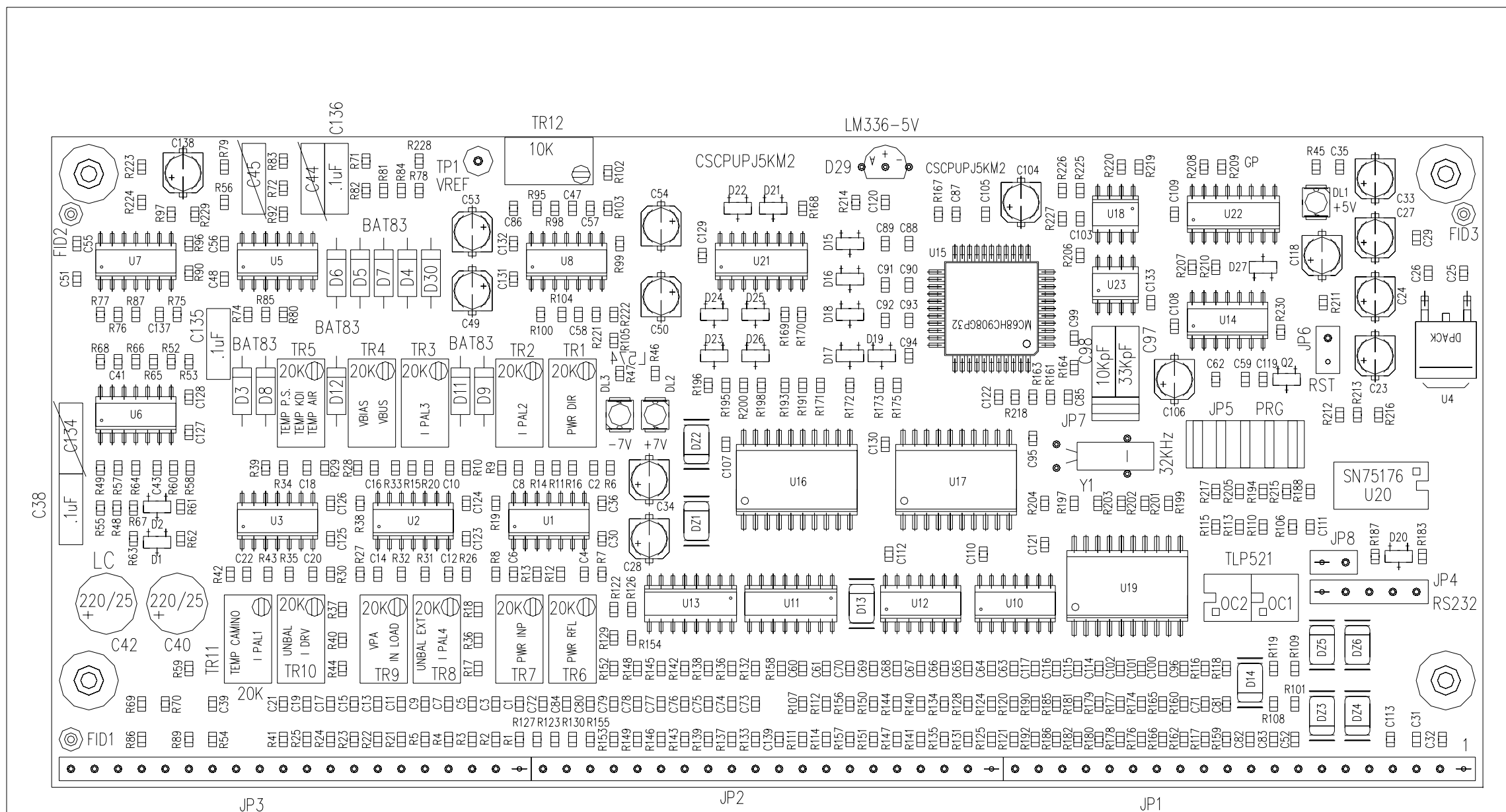

Nome Progetto: PJ5KPS - Scheda CPU		Pagina: 1 di 1	Size: A4
Autore: Griptech - Rev: Canazza	Data: 07/10/2002	Codice Progetto: <>	
Nome PC in Rete: \\UT_SRV	Revisione: 1.0 (DC)	Nome Parte: Scheda CPU	
File/Cartella: PJ5K_CPU_MNT.DWG	Autorizzazione:	Codice: SLCPUPJ5KM2	
Scala: <>	Materiale: <>	Trattamento: <>	Profilo: <>



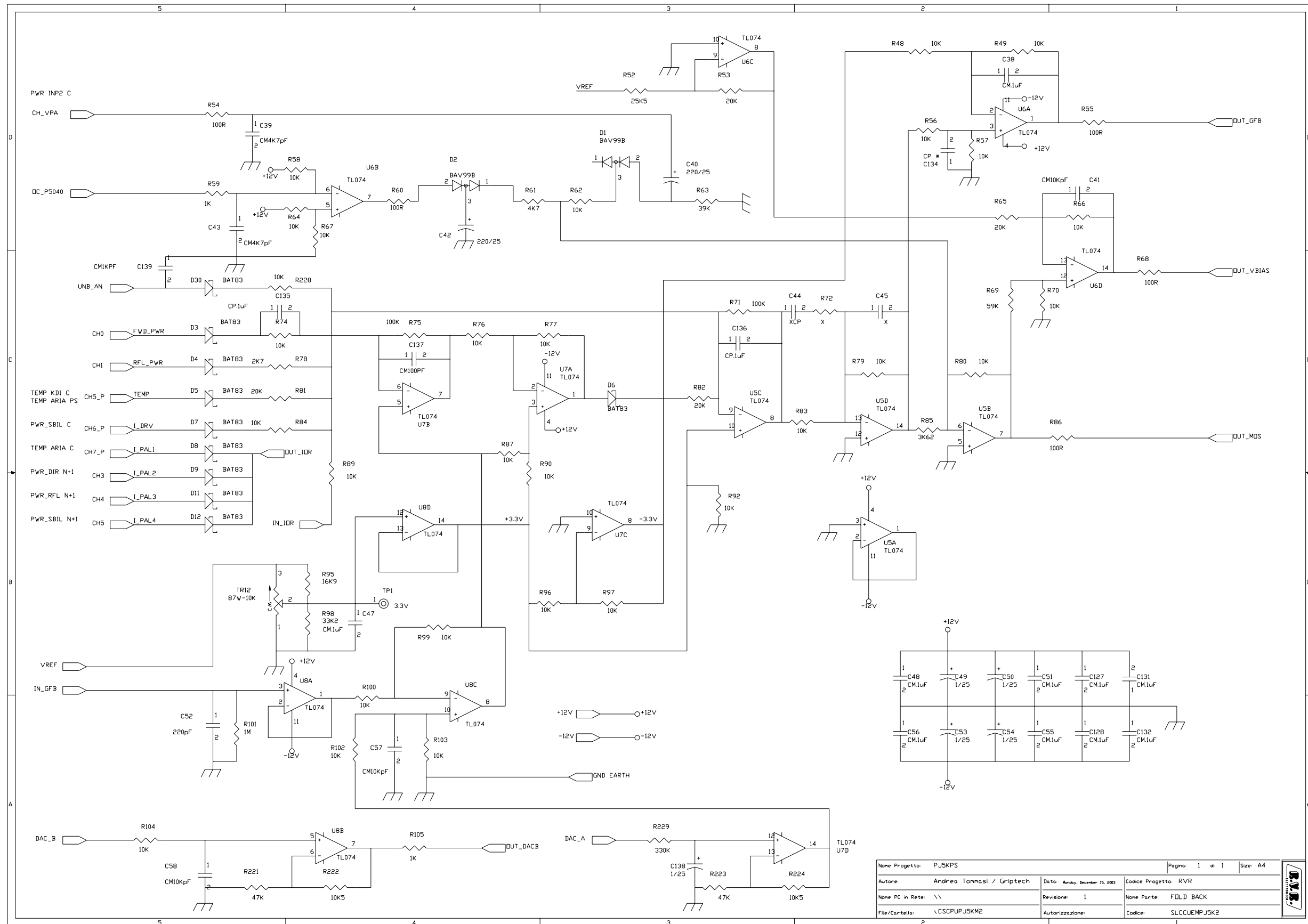

Nome Progetto:	PJ5KPS	Data:	Monday, December 15, 2003	Page:	1 di 1	Size:	A4
Autore:	Andrea Tommasi / Griptech	Revisione:	1	Nome Parte:	FOLD BACK		
None PC in Rete:	\\	Autorizzazione:		Code:	SLCCUEMPJ5K2		
File/Cartella:	\\CSCUP\J5K2						

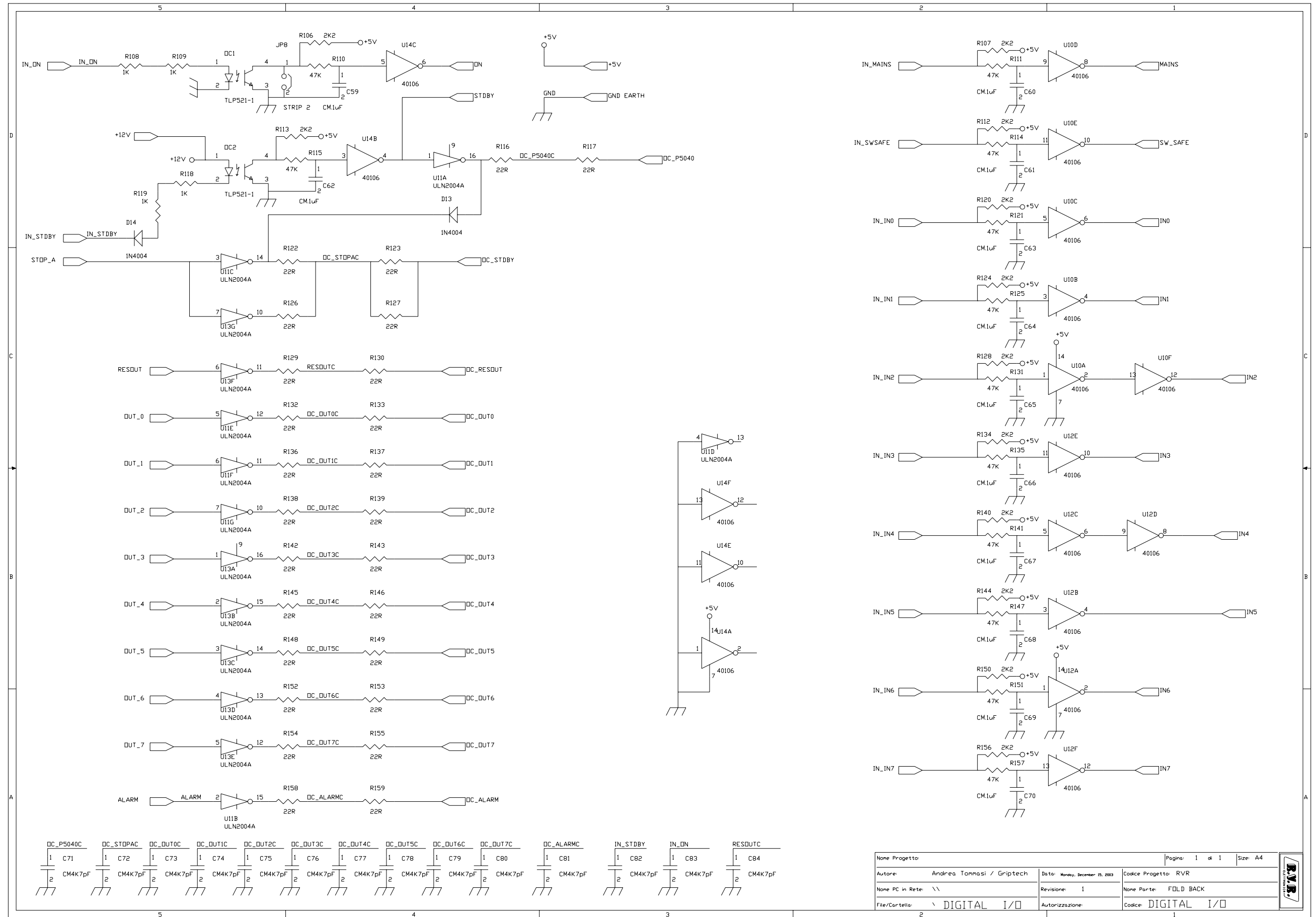

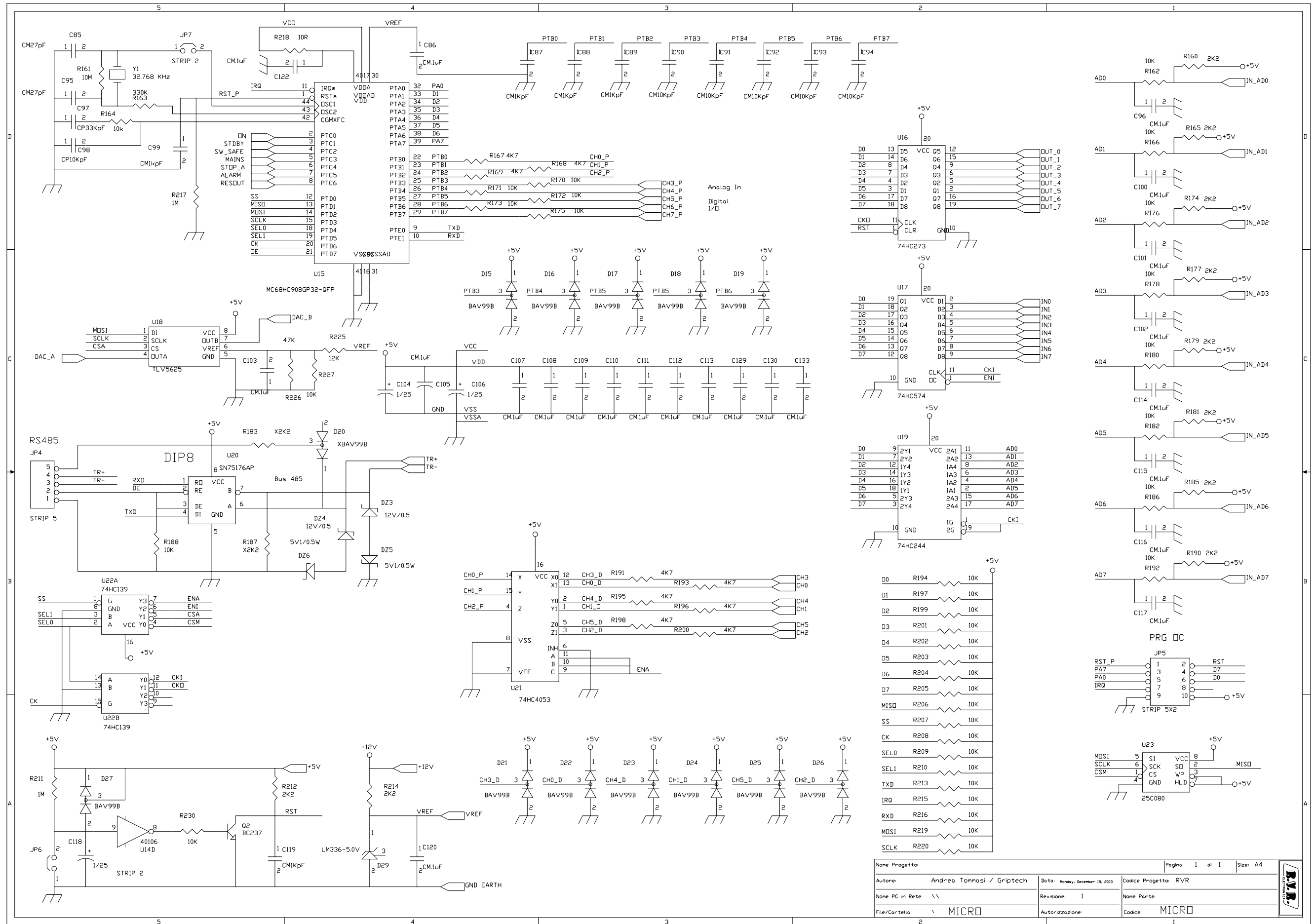

## LISTA MATERIALI

Item	Quantity	Reference	Part
1	17	C1, C3, C5, C7, C9, C11, C13, C15, C17, C19, C21, C87, C88, C89, C99, C119, C139	CM1kpF
2	12	C2, C4, C6, C8, C10, C12, C14, C16, C18, C20, C85, C95	CM27pF
3	1	C22	27pF
4	14	C23, C24, C27, C28, C33, C34, C49, C50, C53, C54, C104, C106, C118, C138	1/25
5	55	C25, C26, C29, C30, C35, C36, C38, C47, C48, C51, C55, C56, C59, C60, C61, C62, C63, C64, C65, C66, C67, C68, C69, C70, C86, C96, C100, C101, C102, C103, C105, C107, C108, C109, C110, C111, C112, C113, C114, C115, C116, C117, C120, C122, C123, C124, C125, C126, C127, C128, C129, C130, C131, C132, C133	CM.1uF
6	19	C31, C32, C39, C43, C71, C72, C73, C74, C75, C76, C77, C78, C79, C80, C81, C82, C83, C84, C121	CM4K7pF
7	2	C42, C40	220/25
8	8	C41, C57, C58, C90, C91, C92, C93, C94	CM10KpF
9	1	C44	XCP
10	2	R72, C45	X
11	1	C52	220pF
12	1	C97	CP33KpF
13	1	C98	CP10KpF
14	1	C134	CP *
15	2	C136, C135	CP.1uF
16	1	C137	CM100PF
17	3	DL1, DL2, DL3	LED
18	2	DZ1, DZ2	5V1/1W
19	2	DZ4, DZ3	12V/0.5
20	2	DZ6, DZ5	5V1/0.5W
21	14	D1, D2, D15, D16, D17, D18, D19, D21, D22, D23, D24, D25, D26, D27	BAV99B
22	10	D3, D4, D5, D6, D7, D8, D9, D11, D12, D30	BAT83
23	2	D14, D13	1N4004
24	1	D20	XBAV99B
25	1	D29	LM336-5.0V
26	4	FIX1, FIX2, FIX3, FIX4	FIX35
27	3	JP1, JP2, JP3	STRIP20
28	1	JP4	STRIP 5
29	1	JP5	STRIP 5X2
30	3	JP6, JP7, JP8	STRIP 2
31	2	OC1, OC2	TLP521-1
32	1	Q2	BC237
33	20	R1, R2, R3, R4, R5, R21, R22, R23, R24, R25, R41, R45, R46, R47, R59, R105, R108, R109, R118, R119	1K
34	16	R6, R7, R8, R9, R10, R26, R27, R28, R29, R30, R42, R54, R55, R60, R68, R86	100R
35	13	R11, R12, R13, R14, R15, R31, R32, R33, R34, R35, R43, R71, R75	100K
36	33	R16, R17, R18, R19, R20, R36, R37, R38, R39, R40, R44, R106, R107, R112, R113, R120, R124, R128, R134, R140, R144, R150, R156, R160, R165, R174, R177, R179, R181, R185, R190, R212, R214	2K2

Item	Quantity	Reference	Part
37	64	R48, R49, R56, R57, R58, R62, R64, R66, R67, R70, R74, R76, R77, R79, R80, R83, R84, R87, R89, R90, R92, R96, R97, R99, R100, R102, R103, R104, R162, R164, R166, R170, R171, R172, R173, R175, R176, R178, R180, R182, R186, R188, R192, R194, R197, R199, R201, R202, R203, R204, R205, R206, R207, R208, R209, R210, R213, R215, R216, R219, R220, R227, R228, R230	10K
38	1	R52	25K5
39	4	R53, R65, R81, R82	20K
40	10	R61, R167, R168, R169, R191, R193, R195, R196, R198, R200	4K7
41	1	R63	39K
42	1	R69	59K
43	1	R78	2K7
44	1	R85	3K62
45	1	R95	16K9
46	1	R98	33K2
47	3	R101, R211, R217	1M
48	15	R110, R111, R114, R115, R121, R125, R131, R135, R141, R147, R151, R157, R221, R223, R226	47K
49	26	R116, R117, R122, R123, R126, R127, R129, R130, R132, R133, R136, R137, R138, R139, R142, R143, R145, R146, R148, R149, R152, R153, R154, R155, R158, R159	22R
50	1	R161	10M
51	2	R229, R163	330K
52	2	R187, R183	X2K2
53	1	R218	10R
54	2	R224, R222	10K5
55	1	R225	12K
56	1	TP1	3.3V
57	11	TR1, TR2, TR3, TR4, TR5, TR6, TR7, TR8, TR9, TR10, TR11	87W-20K
58	1	TR12	87W-10K
59	3	U1, U2, U3	LM324
60	1	U4	LM78M05CDT
61	4	U5, U6, U7, U8	TL074
62	3	U10, U12, U14	40106
63	2	U13, U11	ULN2004A
64	1	U15	MC68HC908GP32-QFP
65	1	U16	74HC273
66	1	U17	74HC574
67	1	U18	TLV5625
68	1	U19	74HC244
69	1	U20	SN75176AP
70	1	U21	74HC4053
71	1	U22	74HC139
72	1	U23	25C080
73	1	Y1	32.768 KHz



ADATTATORE CPU PS E COMBINATORE

SLADPPSPJ5KM2

PIANO DI MONTAGGIO

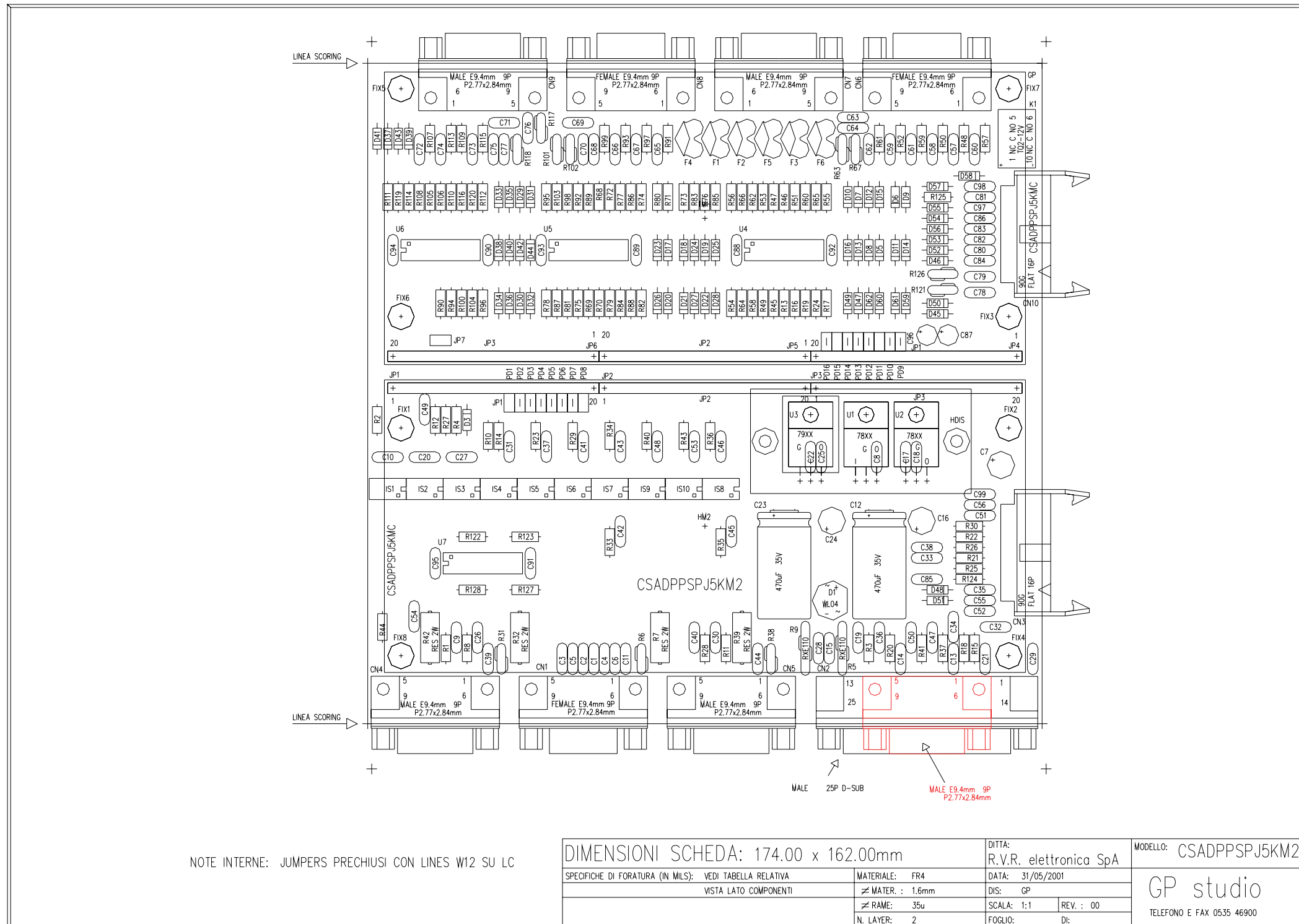

NOTE INTERNE: JUMPERS PRECHIUSI CON LINES W12 SU LC

DIMENSIONI SCHEDA: 174.00 x 162.00mm		DITTA: R.V.R. elettronica SpA	MODELLO: CSADPPSPJ5KM2
SPECIFICHE DI FORATURA (IN MILS): VEDI TABELLA RELATIVA	MATERIALE: FR4	DATA: 31/05/2001	GP studio TELEFONO E FAX 0535 46900
VISTA LATO COMPONENTI	≠ MATER.: 1.6mm	DIS: GP	
	≠ RAME: 35u	SCALA: 1:1	
	N. LAYER: 2	REV.: 00	
		FOGLIO: DI:	

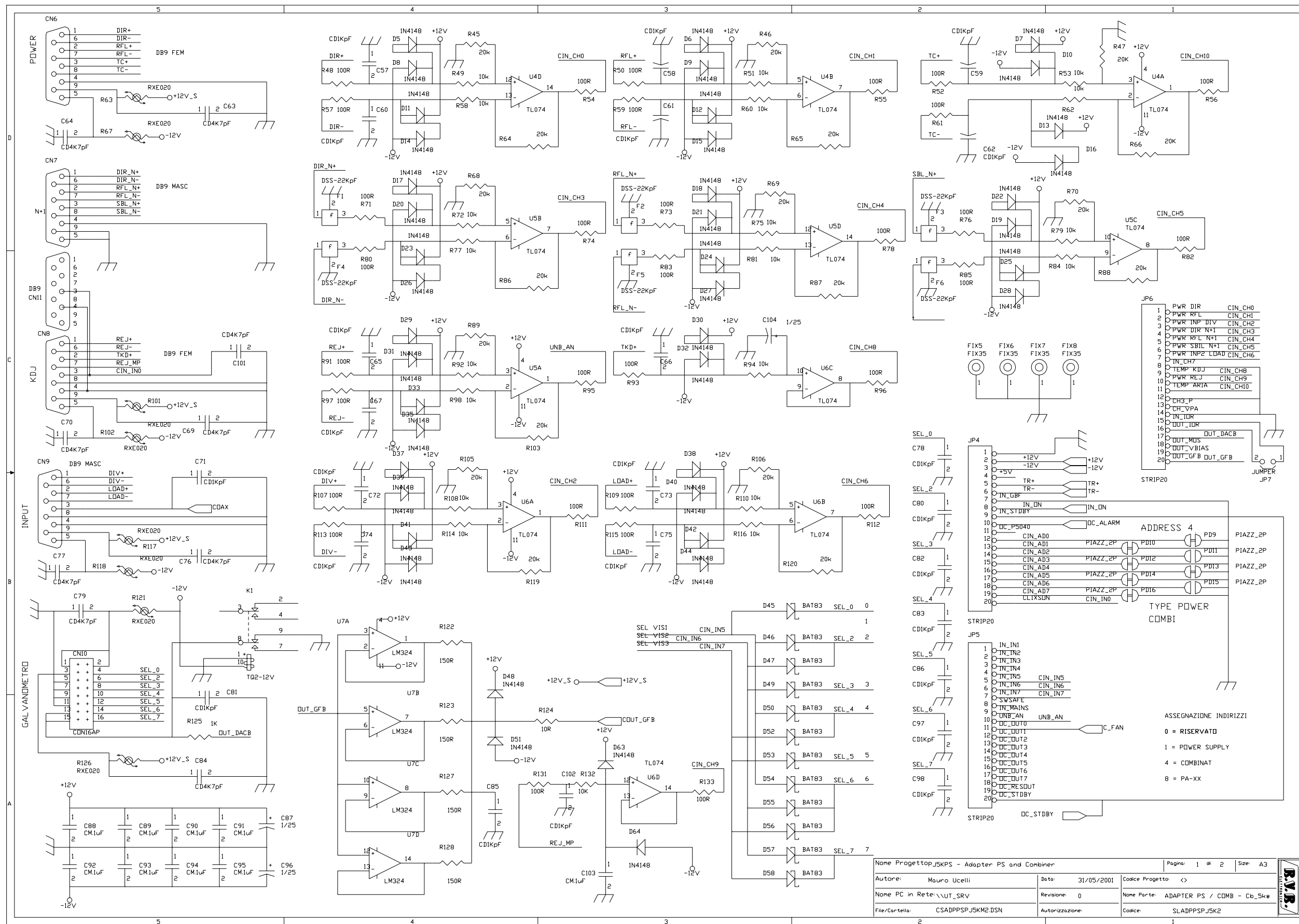

None Progettopj5kps - Adapter PS and Combiner		Pagina: 1 di 2		Size: A3	
Autore:	Maura Ucelli	Data:	31/05/2001	Codice Progetto:	<
Nome PC in Rete:	\\UT_SRV	Revisione:	0	Nome Parte:	ADAPTER PS / COMB - Cb_5k#
File/Cartella:	CSADPPSPJ5KM2.DSN	Autorizzazione:		Codice:	SLADPPSPJ5K2

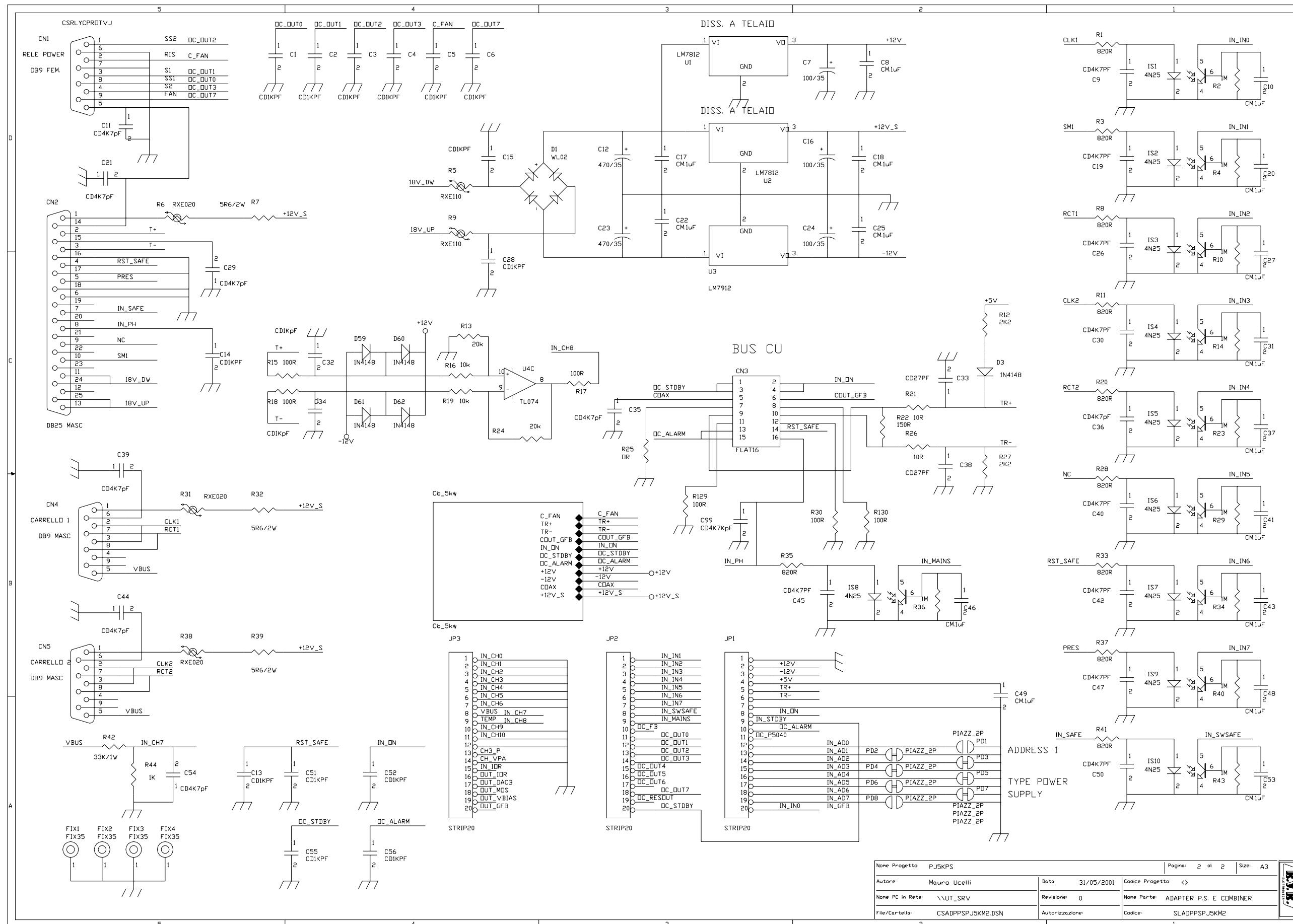

## LISTA MATERIALI

Item	Quantity	Reference	Part
1	1	CN1/CN11	DB9 FEM.
2	1	CN2	DB25 MASC
3	1	CN3	FLAT16
4	4	CN4, CN5, CN7, CN9	DB9 MASC
5	2	CN8, CN6	DB9 FEM
6	1	CN10	CON16AP
7	40	C1, C2, C3, C4, C5, C6, C13, C14, C15, C28, C32, C34, C51, C52, C55, C56, C57, C58, C59, C60, C61, C62, C65, C66, C67, C71, C72, C73, C74, C75, C78, C80, C81, C82, C83, C85, C86, C97, C98, C102	CD1KPF
8	3	C7, C16, C24	100/35
9	25	C8, C10, C17, C18, C20, C22, C25, C27, C31, C37, C41, C43, C46, C48, C49, C53, C88, C89, C90, C91, C92, C93, C94, C95, C103	CM.1uF
10	26	C9, C11, C19, C21, C26, C29, C30, C35, C36, C39, C40, C42, C44, C45, C47, C50, C54, C63, C64, C69, C70, C76, C77, C79, C84, C101	CD4K7pF
11	2	C12, C23	470/35
12	2	C33, C38	CD27PF
13	3	C87, C96, C104	1/25
14	1	C99	CD4K7KpF
15	1	D1	WL02
16	47	D3, D5, D6, D7, D8, D9, D10, D11, D12, D13, D14, D15, D16, D17, D18, D19, D20, D21, D22, D23, D24, D25, D26, D27, D28, D29, D30, D31, D32, D33, D35, D37, D38, D39, D40, D41, D42, D43, D44, D48, D51, D59, D60, D61, D62, D63, D64	1N4148
17	12	D45, D46, D47, D49, D50, D52, D53, D54, D55, D56, D57, D58	BAT83
18	8	FIX1, FIX2, FIX3, FIX4, FIX5, FIX6, FIX7, FIX8	FIX35
19	6	F1, F2, F3, F4, F5, F6	DSS-22KpF
20	10	IS1, IS2, IS3, IS4, IS5, IS6, IS7, IS8, IS9, IS10	4N25
21	6	JP1, JP2, JP3, JP4, JP5, JP6	STRIP20

Item	Quantity	Reference	Part
22	1	JP7	JUMPER
23	1	K1	TQ2-12V
24	16	PD1, PD2, PD3, PD4, PD5, PD6, PD7, PD8, PD9, PD10, PD11, PD12, PD13, PD14, PD15, PD16	PIAZZ_2P
25	10	R1, R3, R8, R11, R20, R28, R33, R35, R37, R41	820R
26	10	R2, R4, R10, R14, R23, R29, R34, R36, R40, R43	1M
27	2	R5, R9	RXE110
28	11	R6, R31, R38, R63, R67, R101, R102, R117, R118, R121, R126	RXE020
29	3	R7, R32, R39	5R6/2W
30	2	R27, R12	2K2
31	20	R13, R24, R45, R46, R47, R64, R65, R66, R68, R69, R70, R86, R87, R88, R89, R103, R105, R106, R119, R120	20k
32	37	R15, R17, R18, R30, R48, R50, R52, R54, R55, R56, R57, R59, R61, R71, R73, R74, R76, R78, R80, R82, R83, R85, R91, R93, R95, R96, R97, R107, R109, R111, R112, R113, R115, R129, R130, R131, R133	100R
33	22	R16, R19, R49, R51, R53, R58, R60, R62, R72, R75, R77, R79, R81, R84, R92, R94, R98, R108, R110, R114, R116, R132	10k
34	3	R21, R26, R124	10R
35	5	R22, R122, R123, R127, R128	150R
36	1	R25	OR
37	1	R42	33K/1W
38	2	R125, R44	1K
39	2	U1, U2	LM7812
40	1	U3	LM7912
41	3	U4, U5, U6	TL074
42	1	U7	LM324

**SCHEDA RETTIFICATRICE TRIFASE**

SLRCTPJ5KMC

PIANO DI MONTAGGIO

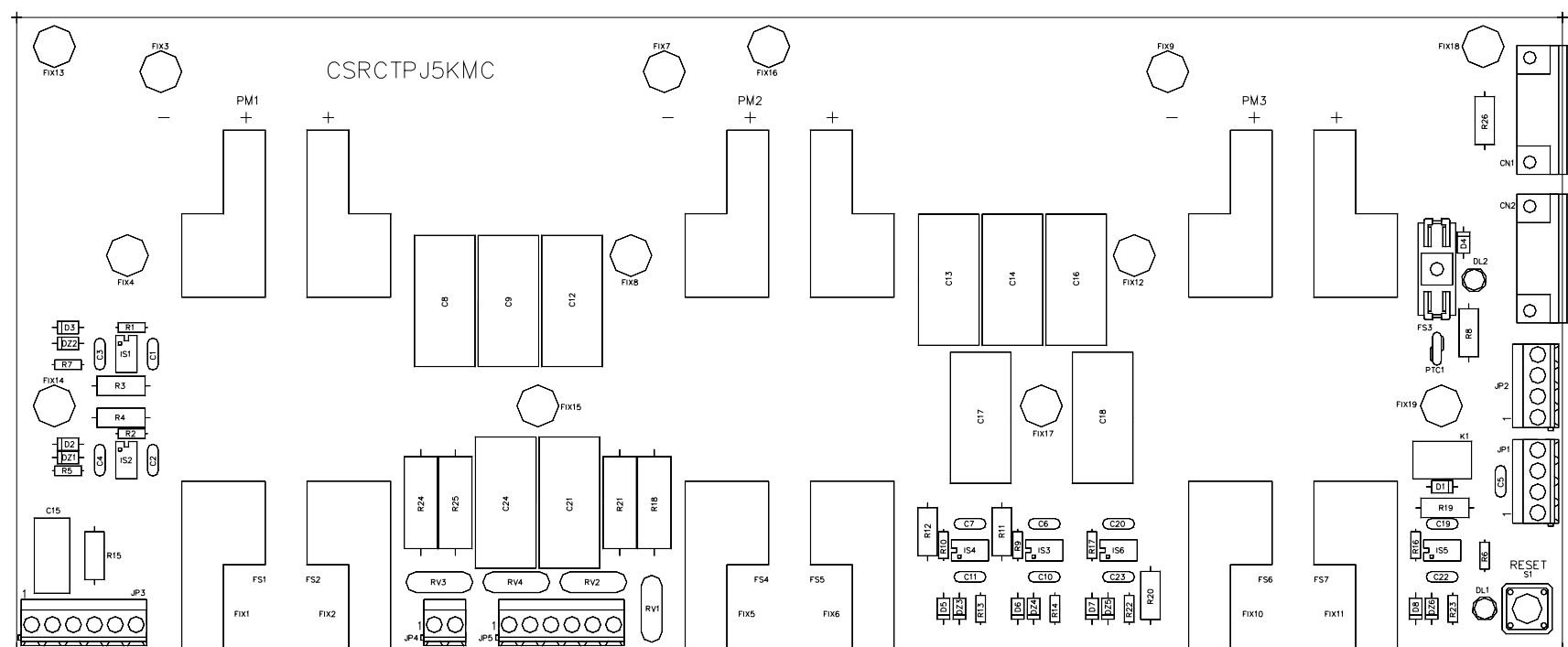

Nome Progetto: PJ5KPS - Rectifier board		Pagina: 1 di 1	Size: A4
Autore: Ucelli - Rev.: Canazza	Data: 17/10/2002	Codice Progetto:	
Name PC in Rete: \\UT_SRV	Revisione: 1.0 (DC)	Nome Parte: Three-phase rectifier	
File/Cartella: RCTPJ5K5_L.Y.DWG	Autorizzazione:	Codice: CSRCTPJ5KMC	
Scala: <>	Materiale: <>	Trattamento: <>	Profilo: <>



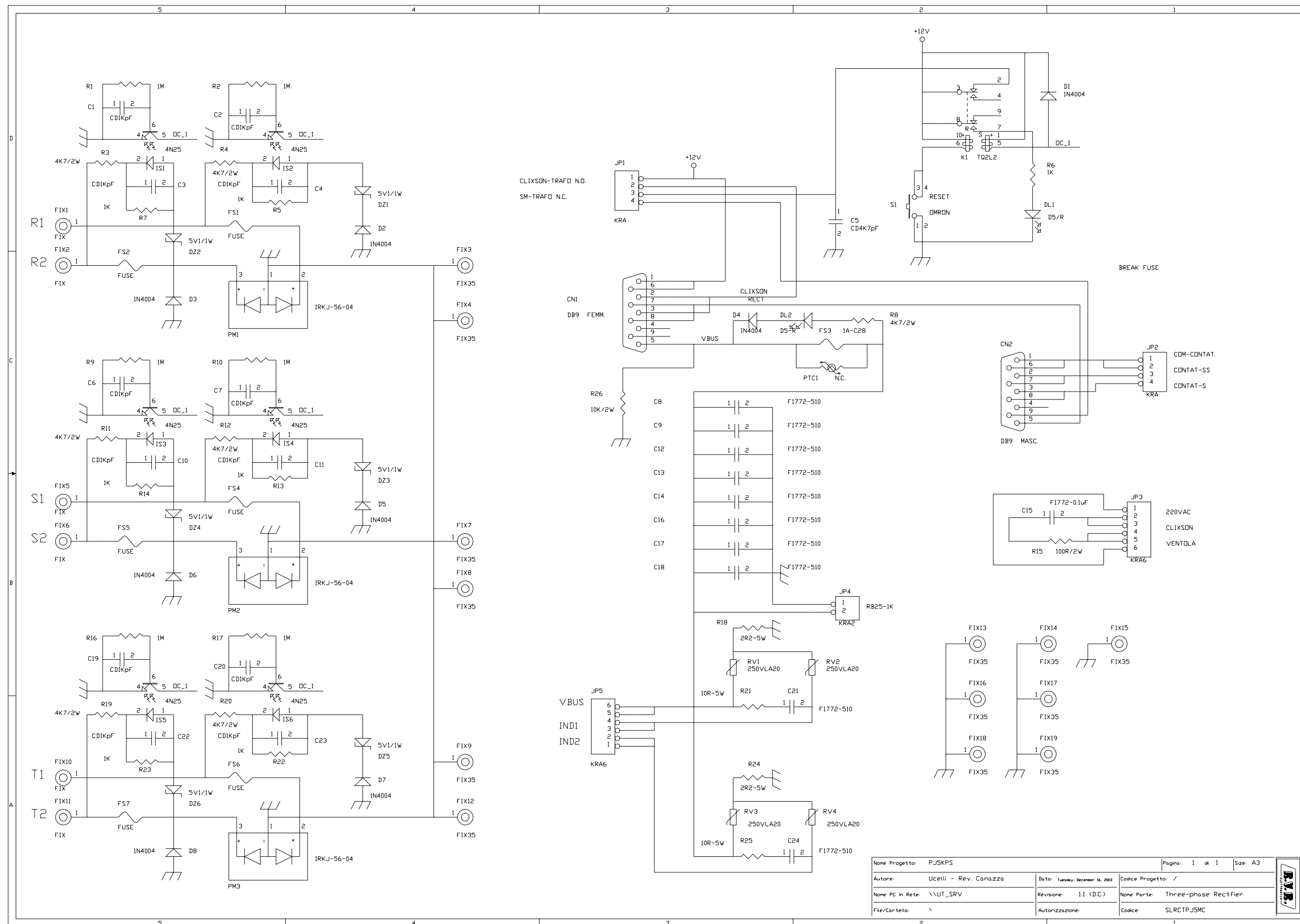

## LISTA MATERIALI

Item	Quantity	Reference	Part
1	1	CN1	DB9 FEMM.
2	1	CN2	DB9 MASC.
3	12	C1,C2,C3,C4,C6,C7,C10,C11,C19,C20,C22,C23	CD1KPF
4	1	C5	CD4K7PF
5	10	C8,C9,C12,C13,C14,C16,C17,C18,C21,C24	F1772-510
6	1	C15	F17720-0.1uF
7	1	DL1	D6R
8	1	DL2	D6R
9	6	DZ1,DZ2,DZ3,DZ4,DZ5,DZ6	5/1/1W
10	7	D1,D2,D3,D5,D6,D7,D8	1N4004
11	1	D4	IN4004
12	6	FIX1, FIX2, FIX5, FIX6, FIX10, FIX11	FIX
13	13	FIX3, FIX4, FIX7, FIX8, FIX9, FIX12, FIX13, FIX14, FIX15, FIX16, FIX17, FIX18, FIX19	FIX35
14	6	FS1, FS2, FS4, FS5, FS6, FS7	FUSE
15	1	FS3	1A-C2B

16	6	IS1, IS2, IS3, IS4, IS5, IS6	4N25
17	2	JP2, JP1	KRA
18	2	JP3, JP5	KRA6
19	1	JP4	KRA2
20	1	K1	TQ2L2
21	3	PM1, PM2, PM3	IRQKJ-56-04
22	1	PTC1	N.C.
23	4	RV1, RV2, RV3, RV4	250VLA20
24	6	R1, R2, R9, R10, R16, R17	1M
25	7	R3, R4, R8, R11, R12, R19, R20	4K7/2W
26	7	R5, R6, R7, R13, R14, R22, R23	1K
27	1	R15	100R/2W
28	2	R18, R24	2R2-5W
29	2	R25, R21	10R-5W
30	1	R26	10W/2W
31	1	S1	OMRON

SCHEDA UNITÀ DI CONTROLLO CPU

SLCCUPJ5KM2

PIANO DI MONTAGGIO

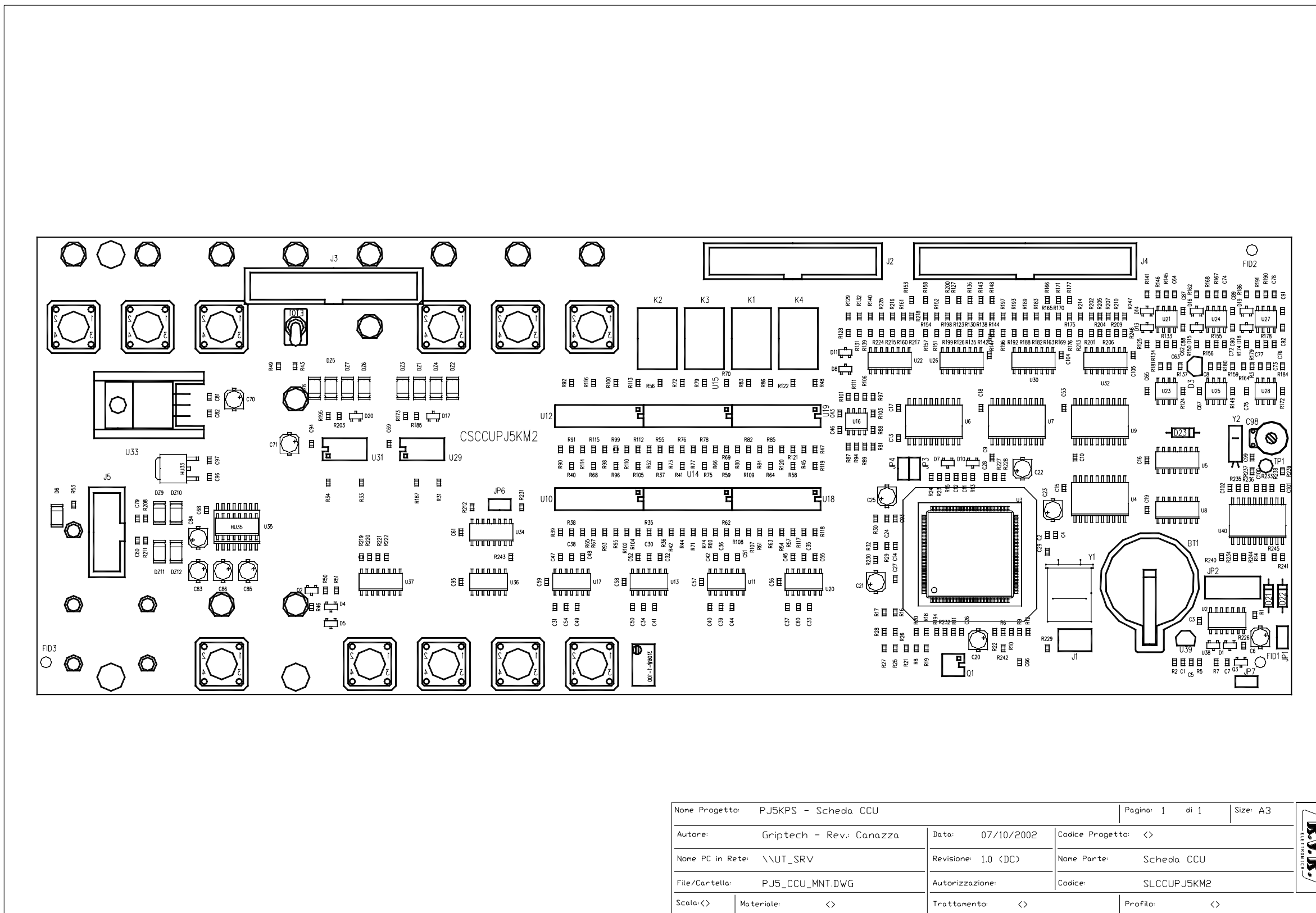

Nome Progetto: PJ5KPS - Scheda CCU		Pagina: 1 di 1		Size: A3
Autore: Griptech - Rev.: Canazza	Data: 07/10/2002	Codice Progetto: <>		
Nome PC in Rete: \\UT_SRV	Revisione: 1.0 (DC)	Nome Parte: Scheda CCU		
File/Cartella: PJ5_CCU_MNT.DWG	Autorizzazione:	Codice: SLCCUPJ5KM2		
Scala: <>	Materiale: <>	Trattamento: <>	Profilo: <>	

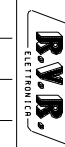



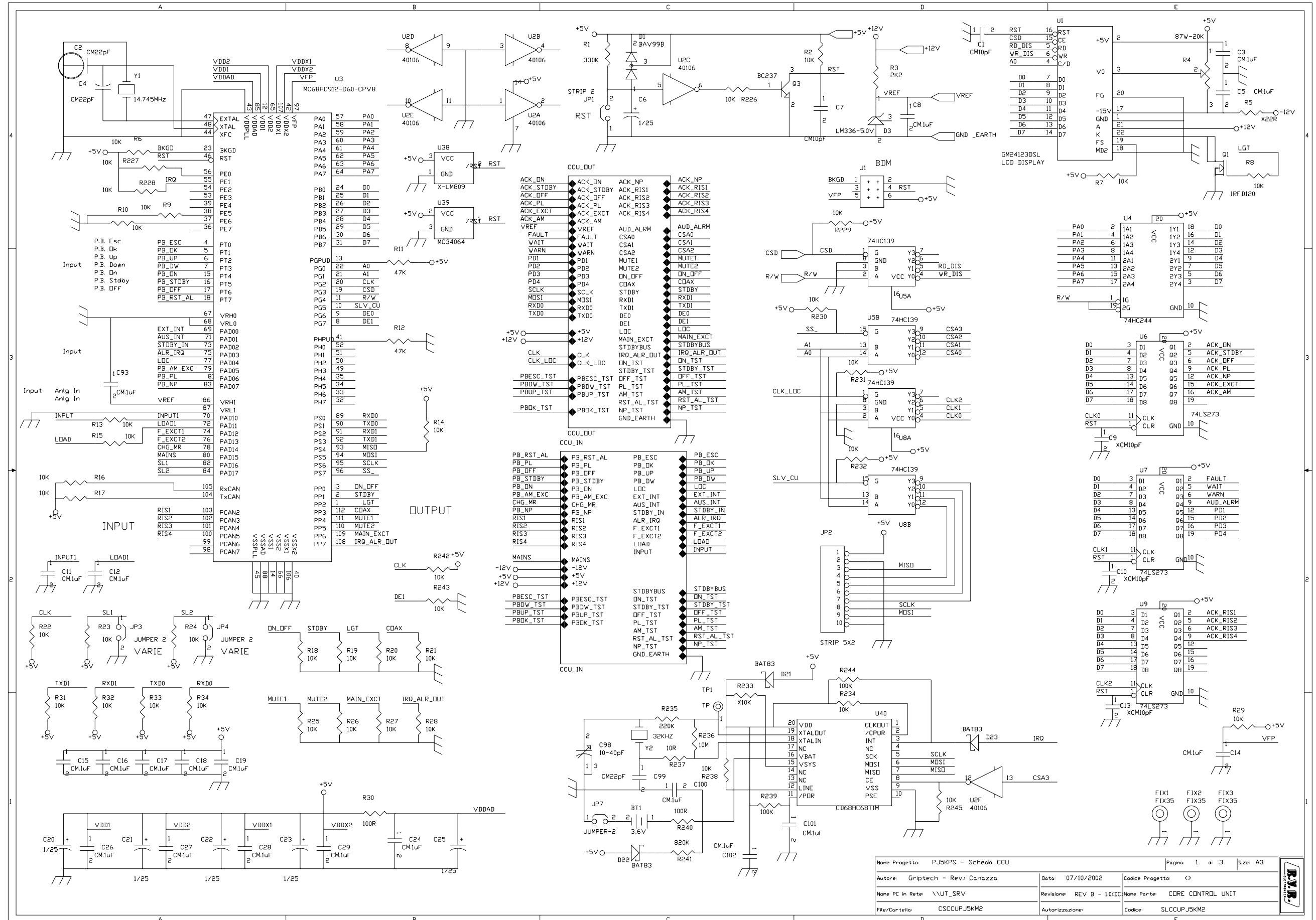

None Progetto:	PJ5KPS - Scheda CCU	Pagina:	1 di 3	Size:	A3
Autore:	GripTech - Rev: Canazza	Data:	07/10/2002	Code Progetto:	<>
None PC in Rete:	\\UT_SRV	Revisione:	REV B - 1.0(DC)	None Parte:	CORE CONTROL UNIT
File/Cartella:	CSCCUPJ5KM2	Autorizzazione:		Code:	SLCCUPJ5KM2

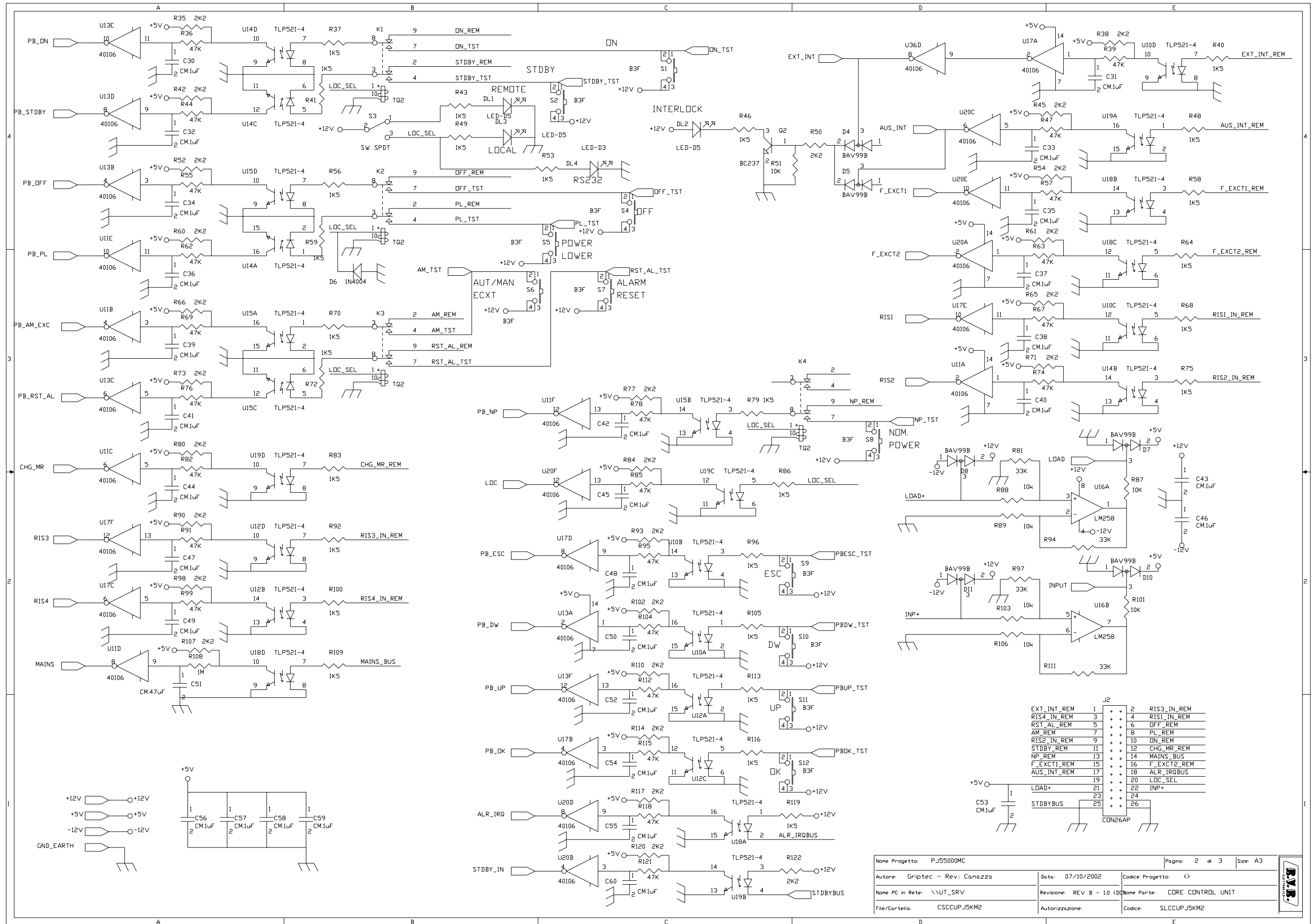

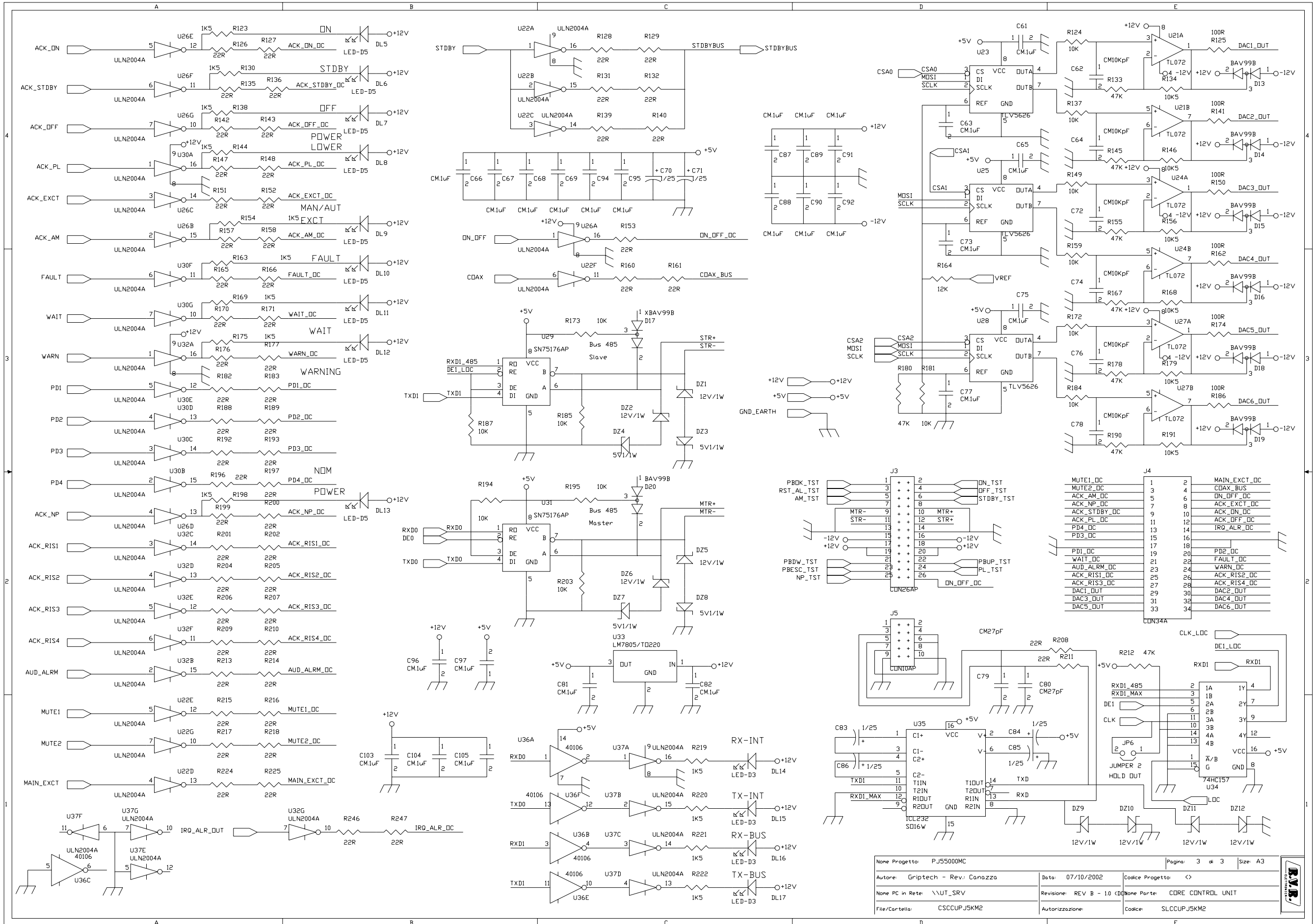

Nome Progetto: PJ55000MC	Page: 3 di 3	Size: A3
Autore: Griptech - Rev: Canazza	Data: 07/10/2002	Codice Progetto: <
Nome PC in Rete: \\UT_SRV	Revisione: REV B - 1.0	None Parte: CORE CONTROL UNIT
File/Carrella: CSCCUPJ5KM2	Autorizzazione:	Codice: SLCCUPJ5KM2

## LISTA MATERIALI

Item	Quantity	Reference	Part
1	1	BT1	3, 6V
2	2	C1, C7	CM10pF
3	3	C2, C4, C99	CM22pF
4	75	C3, C5, C8, C11, C12, C14, C15, C16, C17, C18, C19, C24, C26, C27, C28, C29, C30, C31, C32, C33, C34, C35, C36, C37, C38, C39, C40, C41, C42, C43, C44, C45, C46, C47, C48, C49, C50, C52, C53, C54, C55, C56, C57, C58, C59, C60, C61, C63, C65, C66, C67, C68, C69, C73, C75, C77, C81, C82, C87, C88, C89, C90, C91, C92, C93, C94, C95, C96, C97, C100, C101, C102, C103, C104, C105	CM. 1uF
5	12	C6, C20, C21, C22, C23, C25, C70, C71, C83, C84, C85, C86	1/25
6	3	C9, C10, C13	XCM10pF
7	1	C51	CM. 47uF
8	6	C62, C64, C72, C74, C76, C78	CM10KpF
9	2	C80, C79	CM27pF
10	1	C98	10-40pF
11	12	DL1, DL2, DL3, DL5, DL6, DL7, DL8, DL9, DL10, DL11, DL12, DL13	LED-D5
12	5	DL4, DL14, DL15, DL16, DL17	LED-D3
13	8	DZ1, DZ2, DZ5, DZ6, DZ9, DZ10, DZ11, DZ12	12V/1W
14	4	DZ3, DZ4, DZ7, DZ8	5V1/1W
15	14	D1, D4, D5, D7, D8, D10, D11, D13, D14, D15, D16, D18, D19, D20	BAV99B
16	1	D3	LM336-5.0V
17	1	D6	1N4004
18	1	D17	XBAV99B
19	3	D21, D22, D23	BAT83
20	3	FIX1, FIX2, FIX3	FIX35
21	1	JP1	STRIP 2
22	1	JP2	STRIP 5X2
23	3	JP3, JP4, JP6	JUMPER 2
24	1	JP7	JUMPER-2
25	1	J1	BDM
26	2	J3, J2	CON26AP
27	1	J4	CON34A
28	1	J5	CON10AP
29	4	K1, K2, K3, K4	TQ2
30	1	Q1	IRFD120
31	2	Q3, Q2	BC237
32	1	R1	330K
33	59	R2, R6, R7, R8, R9, R10, R13, R14, R15, R16, R17, R18, R19, R20, R21, R22, R23, R24, R25, R26, R27, R28, R29, R31, R32, R33, R34, R51, R87, R88, R89, R101, R103, R106, R124, R137, R149, R159, R172, R173, R181, R184, R185, R187, R194, R195, R203, R226, R227, R228, R229, R230, R231, R232, R234, R238, R242, R243, R245	10K
34	27	R3, R35, R38, R42, R45, R50, R52, R54, R60, R61, R65, R66, R71, R73, R77, R80, R84, R90, R93, R98, R102, R107, R110, R114, R117, R120, R122	2K2
35	1	R4	87W-20K

Item	Quantity	Reference	Part
36	1	R5	X22R
37	33	R11, R12, R36, R39, R44, R47, R55, R57, R62, R63, R67, R69, R74, R76, R78, R82, R85, R91, R95, R99, R104, R112, R115, R118, R121, R133, R145, R155, R167, R178, R180, R190, R212	47K
38	8	R30, R125, R141, R150, R162, R174, R186, R240	100R
39	40	R37, R40, R41, R43, R46, R48, R49, R53, R56, R58, R59, R64, R68, R70, R72, R75, R79, R83, R86, R92, R96, R100, R105, R109, R113, R116, R119, R123, R130, R138, R144, R154, R163, R169, R175, R198, R219, R220, R221, R222	1K5
40	4	R81, R94, R97, R111	33K
41	1	R108	1M
42	57	R126, R127, R128, R129, R131, R132, R135, R136, R139, R140, R142, R143, R147, R148, R151, R152, R153, R157, R158, R160, R161, R165, R166, R170, R171, R176, R177, R182, R183, R188, R189, R192, R193, R196, R197, R199, R200, R201, R202, R204, R205, R206, R207, R208, R209, R210, R211, R213, R214, R215, R216, R217, R218, R224, R225, R246, R247	22R
43	6	R134, R146, R156, R168, R179, R191	10K5
44	1	R164	12K
45	1	R233	X10K
46	1	R235	220K
47	1	R236	10M
48	1	R237	10R
49	2	R239, R244	100K
50	1	R241	820K
51	11	S1, S2, S4, S5, S6, S7, S8, S9, S10, S11, S12	B3F
52	1	S3	SW SPDT
53	1	TP1	TP
54	1	U1	GM24123DSL
55	6	U2, U11, U13, U17, U20, U36	40106
56	1	U3	MC68HC912-D60-CPV8
57	1	U4	74HC244
58	2	U8, U5	74HC139
59	3	U6, U7, U9	74LS273
60	6	U10, U12, U14, U15, U18, U19	TLP521-4
61	1	U16	LM258
62	3	U21, U24, U27	TL072
63	5	U22, U26, U30, U32, U37	ULN2004A
64	3	U23, U25, U28	TLV5626
65	2	U29, U31	SN75176AP
66	1	U33	LM7805/TO220
67	1	U34	74HC157
68	1	U35	ICL232
69	1	U38	X-LM809
70	1	U39	MC34064
71	1	U40	CD68HC68T1M
72	1	Y1	14.745MHz
73	1	Y2	32KHZ

**SCHEDA UNITÀ DI CONTROLLO MADRE**

SLCCU1PJ5KM2

PIANO DI MONTAGGIO

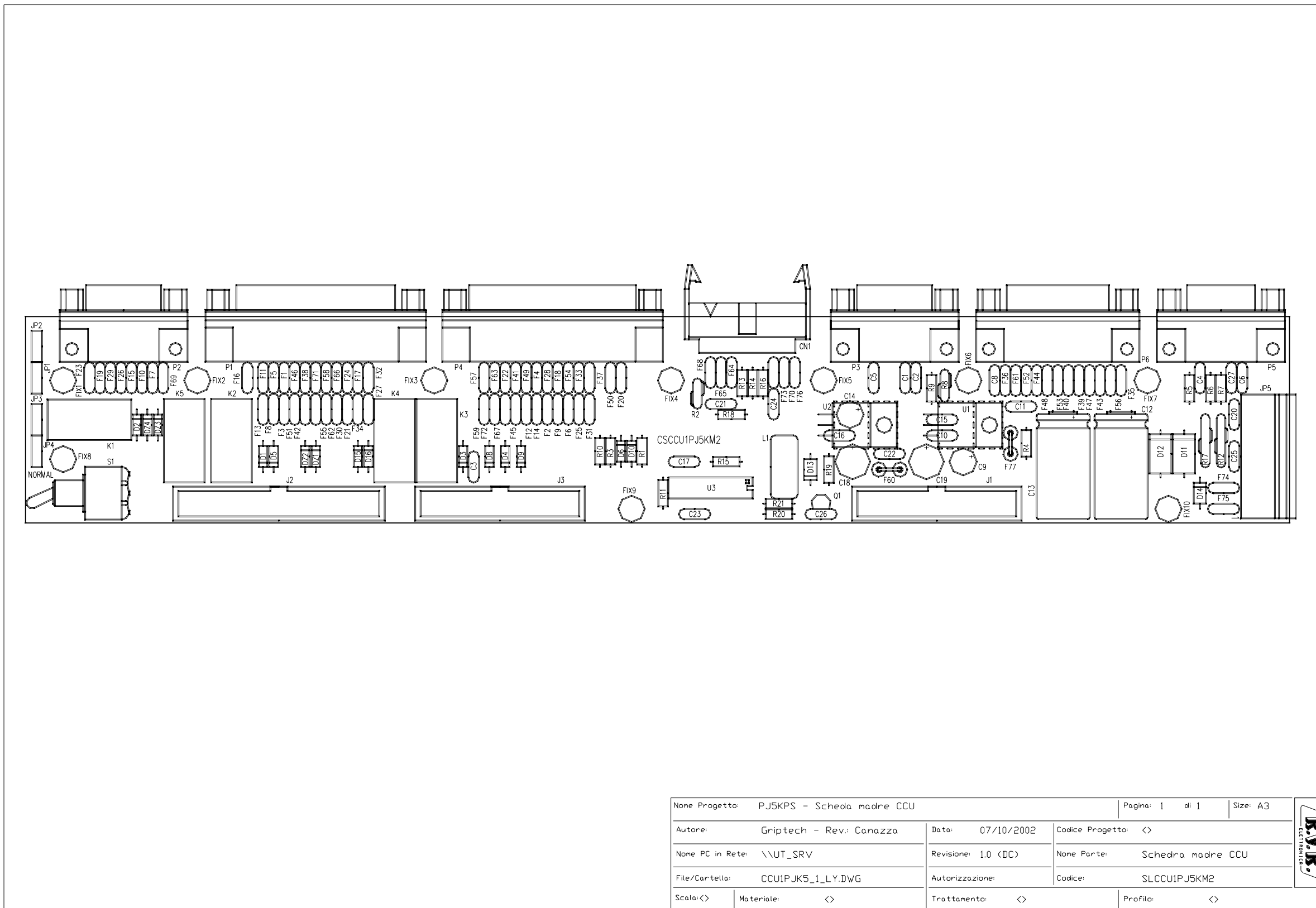

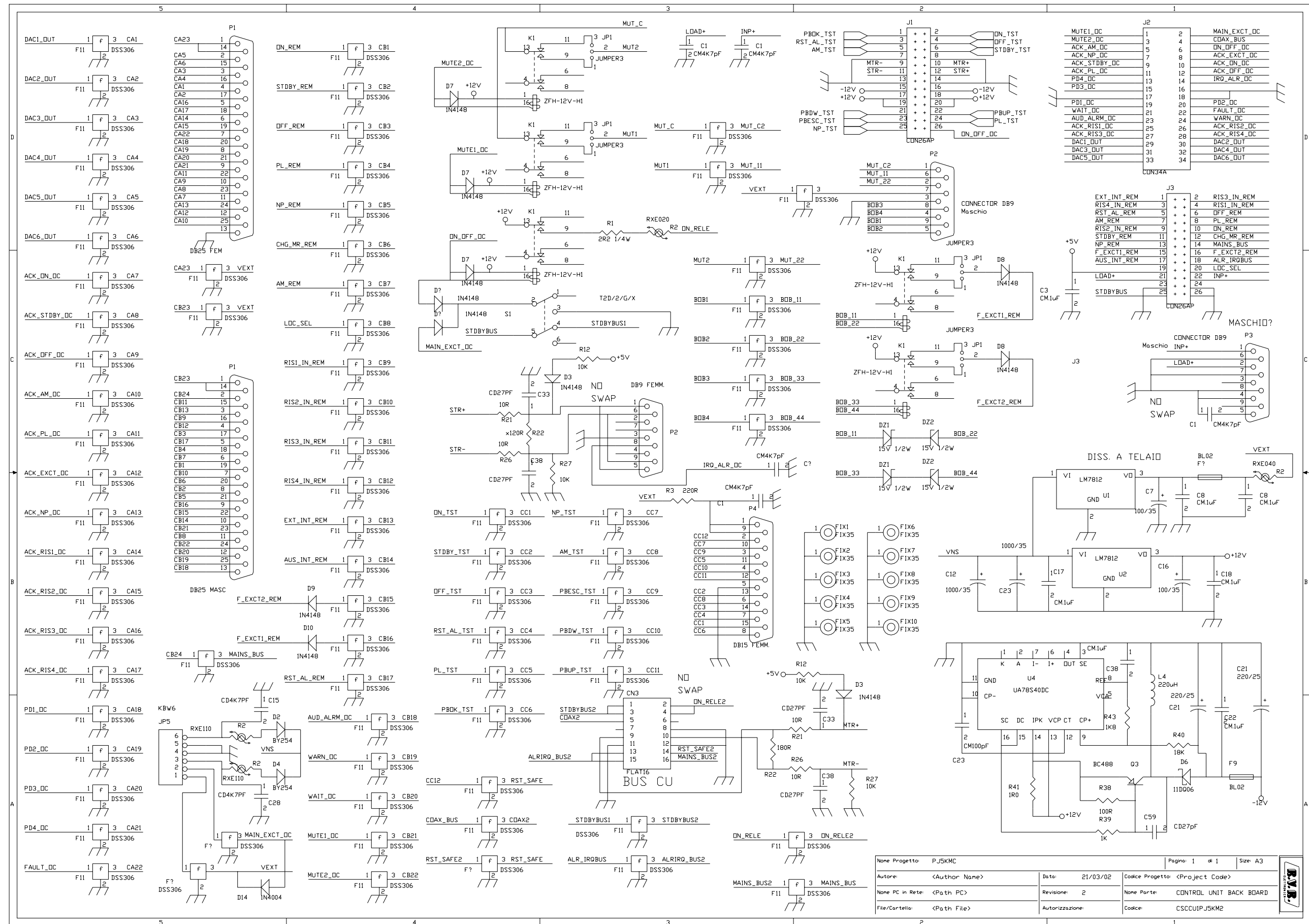

None	Progetto: P_5KMC	Pagina: 1	di 1	Size: A3
Autore:	<Author Name>	Data:	21/03/02	Code: <Project Code>
None	PC in Rete: <Path PC>	Revisione:	2	None
File/Cartella:	<Path File>	Autorizzazione:		Code: CSCCU1P5KM2

## LISTA MATERIALI

Item	Quantity	Reference	Part
1	1	CN1	FLAT16
2	5	C1,C2,C5,C8,C27	CM4K7pF
3	7	C3,C10,C11,C15,C16,C17,C22	CM.1uF
4	5	C4,C6,C21,C24,C26	CD27pF
5	2	C9,C14	100/35
6	2	C12,C13	1000/35
7	2	C19,C18	220/25
8	2	C25,C20	CD4K7PF
9	1	C23	CM100pF
10	4	DZ1,DZ2,DZ3,DZ4	15V 1/2W
11	11	D1,D2,D3,D4,D5,D6,D8,D9, D10,D15,D16	1N4148
12	2	D11,D12	BY254
13	1	D13	11DQ06
14	1	D14	1N4004
15	10	FIX1, FIX2, FIX3, FIX4, FIX5, FIX6, FIX7, FIX8, FIX9, FIX10	FIX35
16	75	F1, F2, F3, F4, F5, F6, F7, F8, F9, F10, F11, F12, F13, F14, F15, F16, F17, F18, F19, F20, F21, F22, F23, F24, F25, F26, F27, F28, F29, F30, F31, F32, F33, F34, F35, F36, F37, F38, F39, F40, F41, F42, F43, F44, F45, F46, F47, F48, F49, F50, F51, F52, F53, F54, F55, F56, F57, F58, F59, F61, F62, F63, F64, F65, F66, F67, F68, F69, F70, F71, F72, F73, F74, F75, F76	DSS306
17	2	F77, F60	BL02
18	4	JP1, JP2, JP3, JP4	JUMPER3
19	1	JP5	KBW6
20	2	J3, J1	CON26AP
21	1	J2	CON34A
22	5	K1, K2, K3, K4, K5	ZFH-12V-H1
23	1	L1	220uH
24	1	P1	DB25 FEM
25	2	P2, P3	CONNECTOR DB9
26	1	P4	DB25 MASC
27	1	P5	DB9 FEMM.
28	1	P6	DB15 FEMM.
29	1	Q1	BC488
30	1	R1	2R2 1/4W
31	1	R2	RXE020
32	4	R3, R7, R10, R18	10K
33	4	R4, R6, R13, R16	10R
34	1	R5	x120R
35	1	R8	RXE040
36	1	R9	220R
37	1	R11	1K8
38	2	R12, R17	RXE110
39	1	R14	180R
40	1	R15	18K
41	1	R19	1R0
42	1	R20	100R
43	1	R21	1K
44	1	S1	T2D/2/G/X
45	2	U1, U2	LM7812
46	1	U3	UA78S40DC

INTERFACCIA PARALLELA

SLINTREMPJ5KM

PIANO DI MONTAGGIO

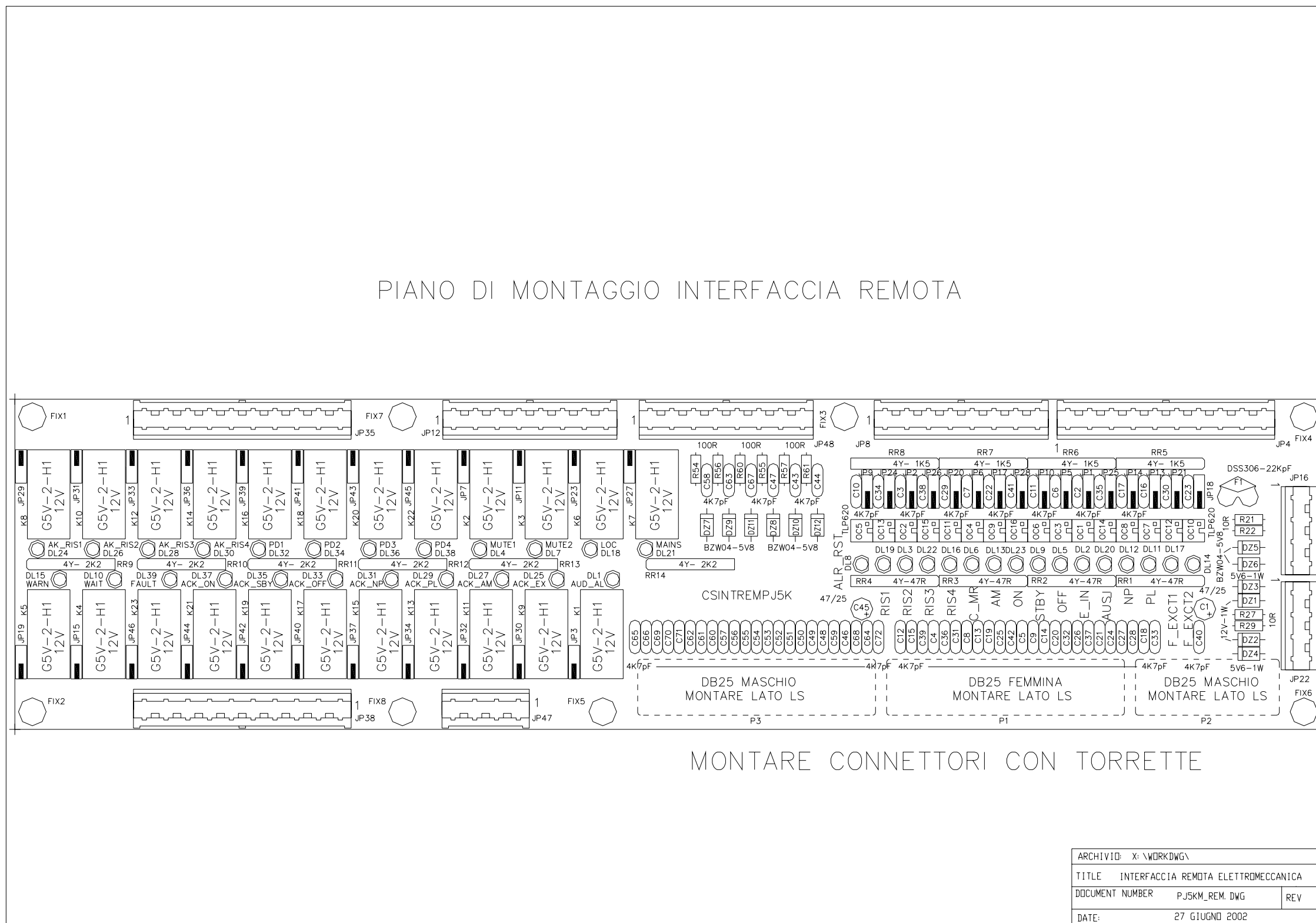



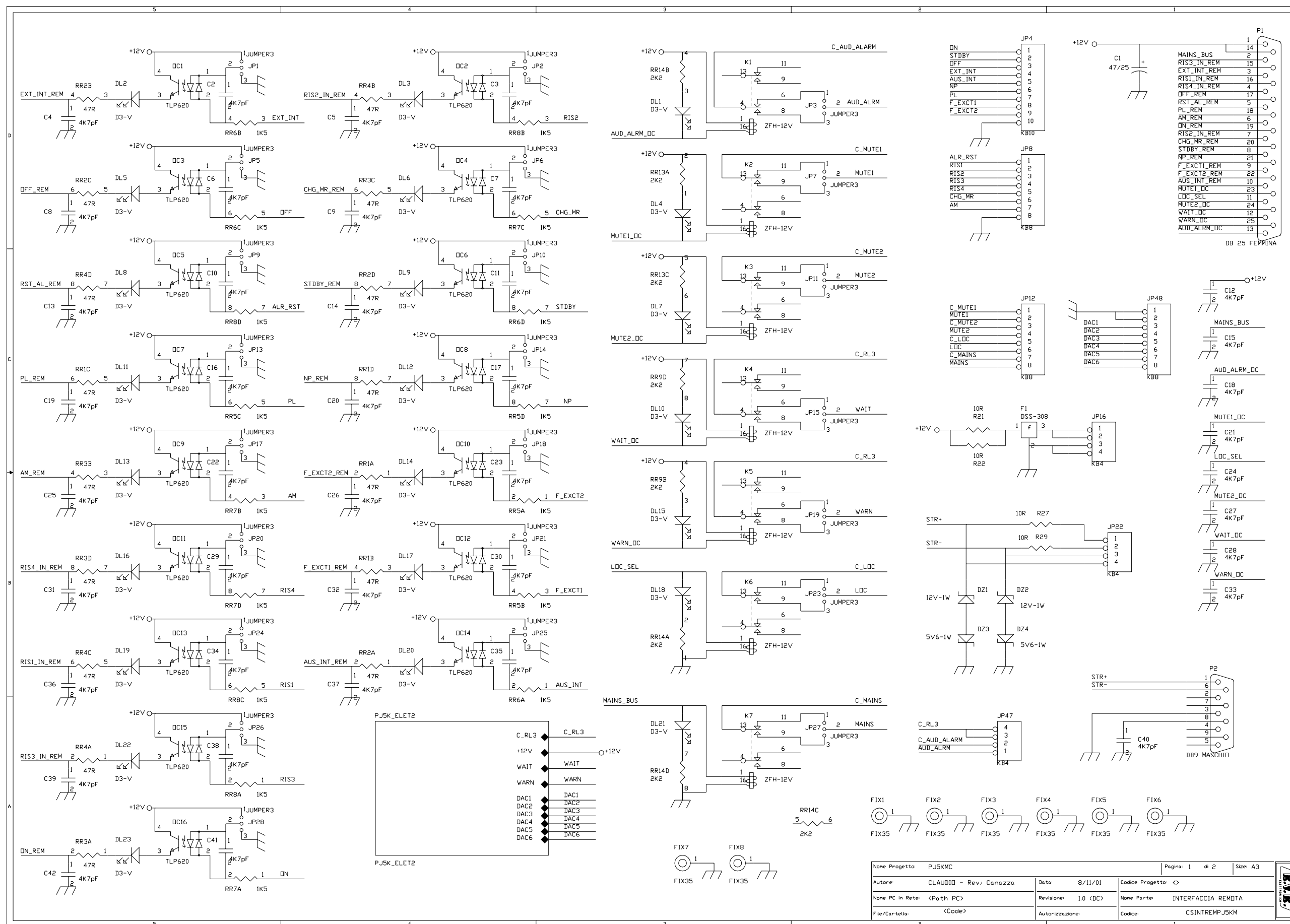

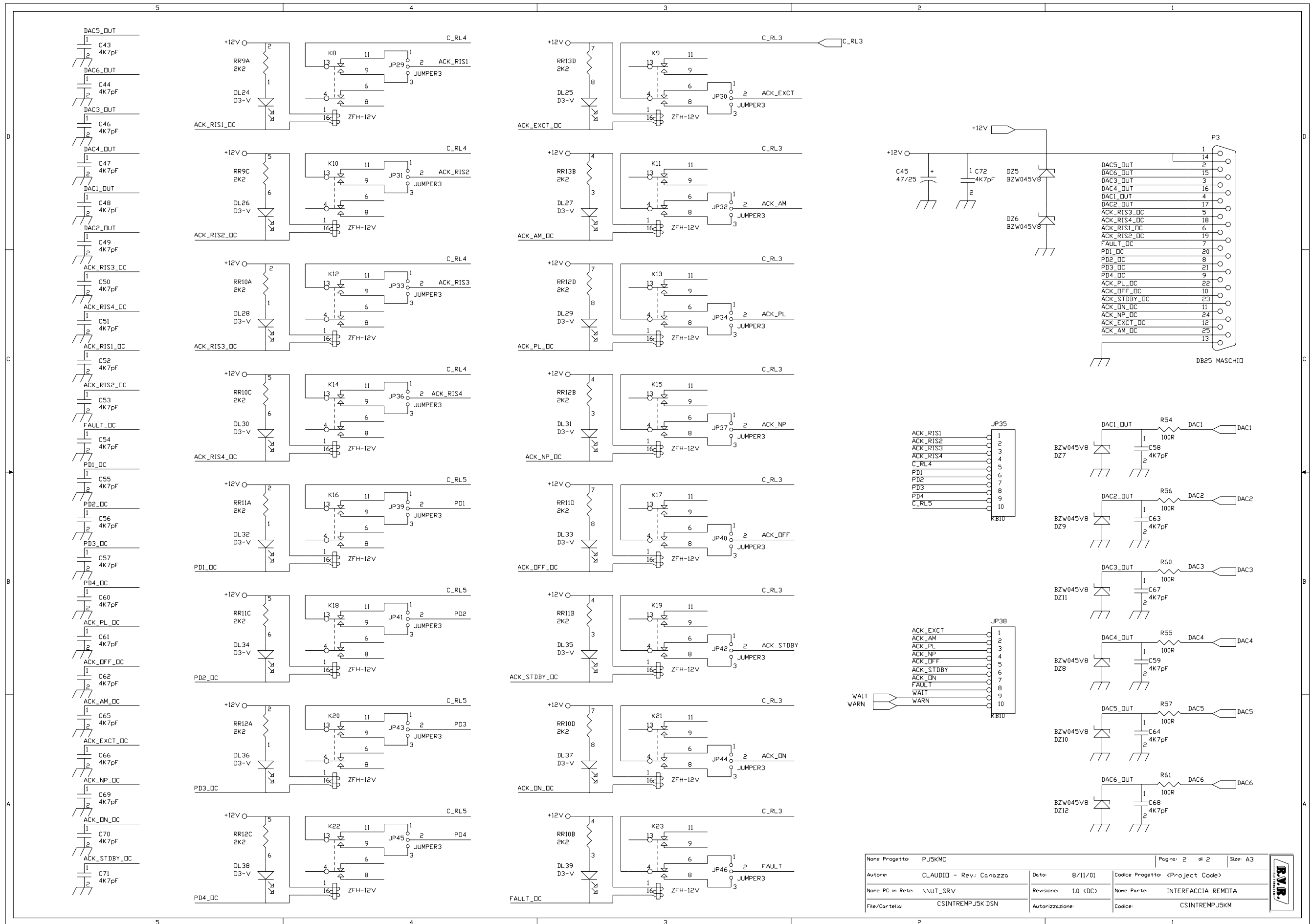

Nome Progetto:	PJ5KMC	Pagina:	2 di 2	Size:	A3
Autore:	CLAUDIO - Rev: Conazza	Data:	8/11/01	Codice Progetto:	<Project Code>
Nome PC in Rete:	\\UT_SRV	Revisione:	1.0 (DC)	Nome Parte:	INTERFACCIA REMDTA
File/Carrella:	CSINTREMPJ5K.DSN	Autorizzazione:		Codice:	CSINTREMPJ5KM

## LISTA MATERIALI

ITEM	Q. TY	REFERENCE	PART
1	2	C1, C45	47/25
2	70	C2, C3, C4, C5, C6, C7, C8, C9, C10, C11, C12, C14, C15, C16, C17, C18, C19, C20, C21, C22, C23, C24, C25, C26, C27, C28, C29, C30, C31, C32, C32, C33, C34, C35, C36, C37, C38, C39, C40, C41, C42, C43, C44, C46, C47, C48, C49, C50, C51, C52, C53, C54, C55, C56, C57, C56, C57, C58, C59, C60, C61, C62, C63, C64, C65, C66, C67, C68, C69, C70, C71, C72	4K7Pf
3	39	DL1, DL2, DL3, DL4, DL5, DL6, DL7, DL8, DL9, DL10, DL11, DL12, DL13, DL14, DL15, DL16, DL17, DL18, DL19, DL20, DL21, DL22, DL23, DL24, DL25, DL26, DL27, DL28, DL29, DL30, DL31, DL32, DL33, DL34, DL35, DL36, DL37, DL38, DL39	D3-V
4	2	DZ2, DZ1	12V-1N
5	2	DZ4, DZ3	5V6-1N
6	8	DZ5, DZ6, DZ7, DZ8, DZ9, DZ10, DZ11, DZ12	BZK045V8
7	8	FIX1, FIX2, FIX3, FIX4, FIX5, FIX6, FIX7, FIX8	FIX35
8	1	F1	DSS-308
9	39	JP1, JP2, JP3, JP5, JP6, JP7, JP9, JP10, JP11, JP13, JP14, JP15, JP17, JP18, JP19, JP20, JP21, JP23, JP24, JP25, JP26, JP27, JP28, JP29, JP30, JP31, JP32, JP33, JP34, JP36, JP37, JP39, JP40, JP41, JP42, JP43, JP44, JP45, JP46	JUMPER3
10	3	JP4, JP35, JP8	KB10
11	3	JP8, JP12, JP48	KBS
12	3	JP16, JP22, JP47	KB4
13	23	K1, K2, K3, K4, K5, K6, K7, K8, K9, K10, K11, K12, K13, 14, K15, K16, K17, K18, K19, K20, K21, K22, K23	ZFH-12V
14	16	OC1, OC2, OC3, OC4, OC5, OC6, OC7, OC8, OC9, OC10, OC11, OC12, OC13, OC14, OC14, OC15, OC16	TLP620
15	1	P1	DB 25 FEMMINA
16	1	P2	DB9 MASCHIO
17	1	P3	DB25 MASCHIO
18	4	RR1, RR2, RR3, RR4	47R
19	4	RR5, RR6, RR7, RR8	1K5
20	6	RR9, RR10, RR11, RR12, RR13, RR14	2K2
21	4	R21, R22, R27, R29	10R
22	6	R54, R55, R56, R57, R60, R61	100R

SPLITTER/SCAMBIATORE INGRESSO

CSSPLINA10K2 – CSSPLINB10K2

PIANO DI MONTAGGIO

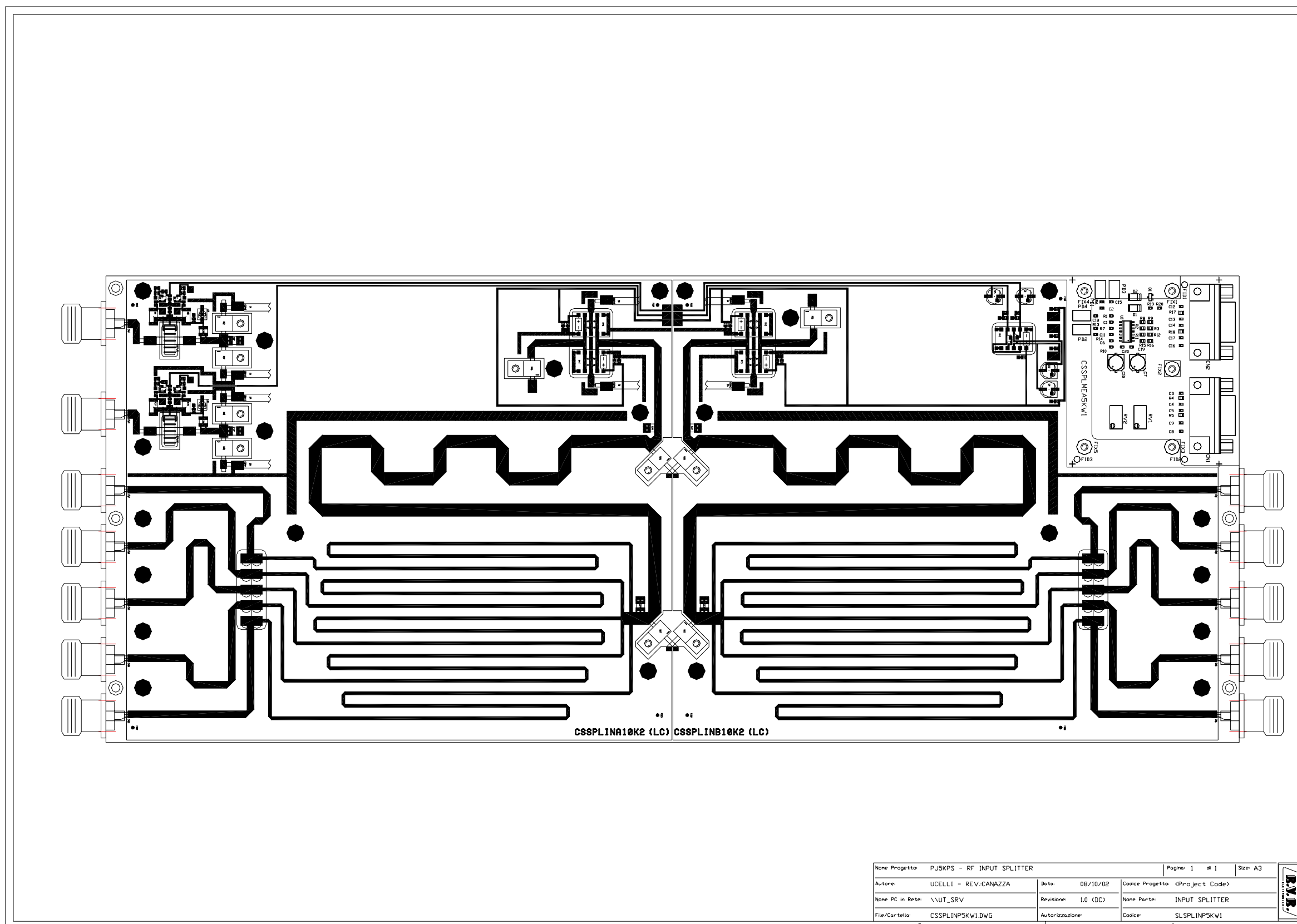

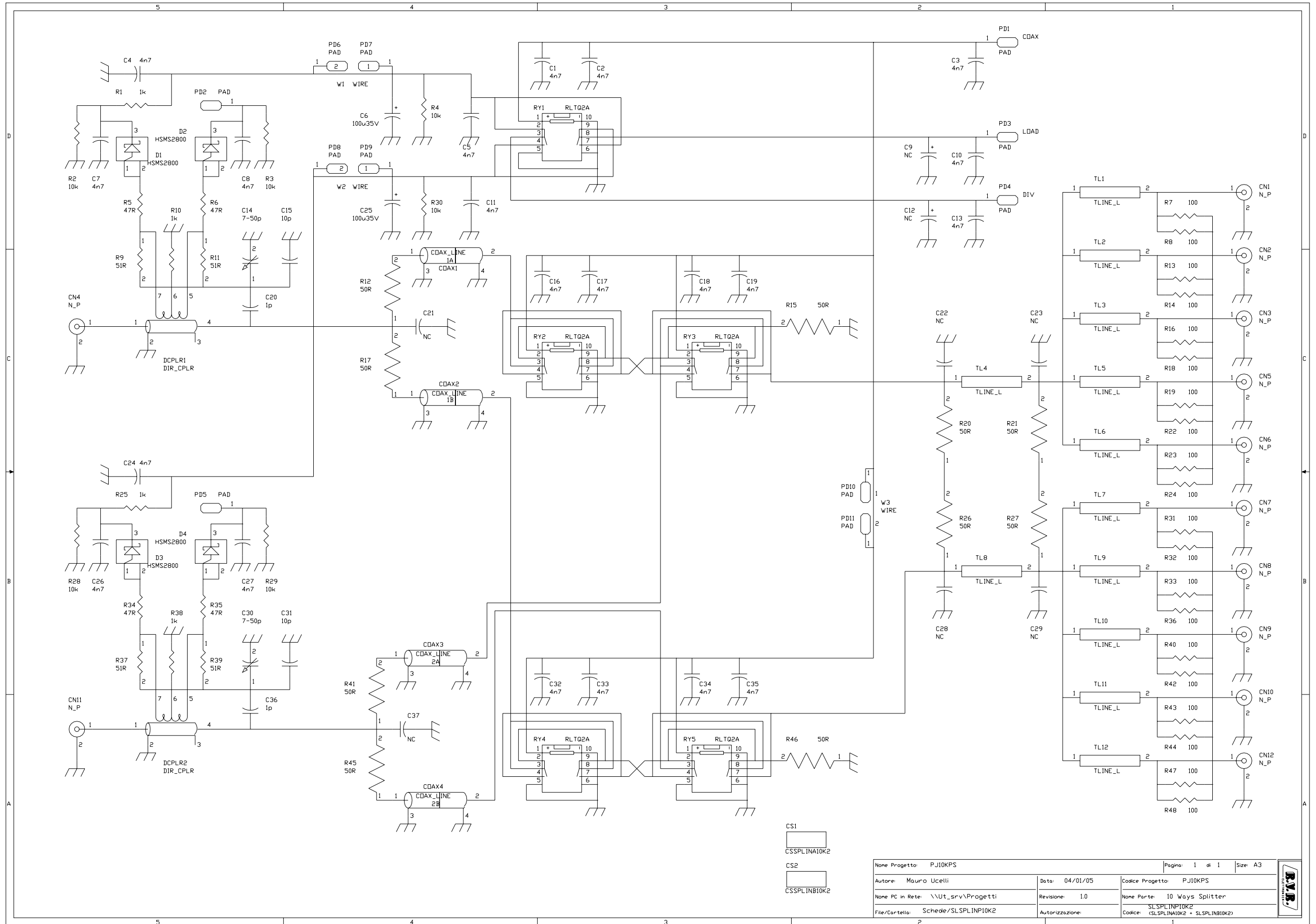

Nome Progetto: PJ10KPS	Pagina: 1 di 1	Size: A3
Autore: Mauro Ucelli	Data: 04/01/05	Codice Progetto: PJ10KPS
Nome PC in Rete: \\Ut_srv\Progetti	Revisione: 1.0	Nome Parte: 10 Ways Splitter
File/Cartella: Schede/SLSPIN10K2	Autorizzazione:	Codice: SLSPIN10K2 (SLSPIN10K2 + SLSPIN10K2)

## LISTA MATERIALI

Item	Quantity	Reference	Part
1	12	CN1, CN2, CN3, CN4, CN5, CN6, CN7, CN8, CN9, CN10, CN11, CN12	N_P
2	4	COAX1, COAX2, COAX3, COAX4	COAX LINE
3	1	CS1	CSSPLINA10K2
4	1	CS2	CSSPLINB10K2
5	21	C1, C2, C3, C4, C5, C7, C8, C10, C11, C13, C16, C17, C18, C19, C24, C26, C27, C32, C33, C34, C35	4n7
6	2	C25, C6	100u35V
7	8	C9, C12, C21, C22, C23, C28, C29, C37	NC
8	2	C14, C30	7-50p
9	2	C31, C15	10p
10	2	C36, C20	1p
11	2	DCPLR1, DCPLR2	DIR CPLR
12	4	D1, D2, D3, D4	HSMS2800
13	11	PD1, PD2, PD3, PD4, PD5, PD6, PD7, PD8, PD9, PD10, PD11	PAD
14	5	RY1, RY2, RY3, RY4, RY5	RLTQ2A
15	4	R1, R10, R25, R38	1k
16	6	R2, R3, R4, R28, R29, R30	10k
17	4	R5, R6, R34, R35	47R
18	20	R7, R8, R13, R14, R16, R18, R19, R22, R23, R24, R31, R32, R33, R36, R40, R42, R43, R44, R47, R48	100
19	4	R9, R11, R37, R39	51R
20	10	R12, R15, R17, R20, R21, R26, R27, R41, R45, R46	50R
21	12	TL1, TL2, TL3, TL4, TL5, TL6, TL7, TL8, TL9, TL10, TL11, TL12	TLINE_L
22	3	W1, W2, W3	WIRE

**SCHEDA CPU MISURE SBILANCIAMENTO**

SLADKDIPJ5K2

PIANO DI MONTAGGIO

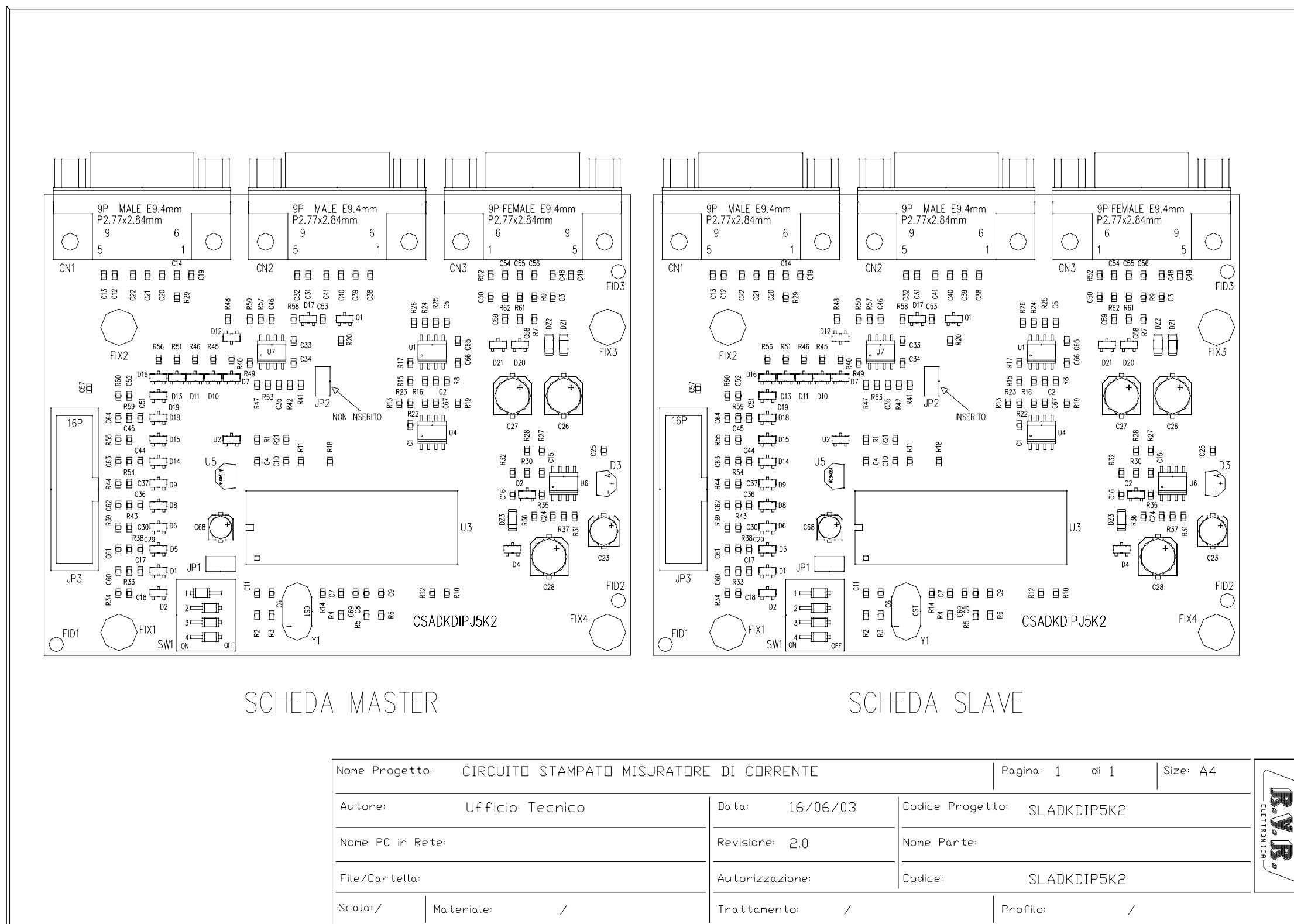

SCHEDA MASTER

SCHEDA SLAVE

Nome Progetto: CIRCUITO STAMPATO MISURATORE DI CORRENTE		Pagina: 1 di 1	Size: A4
Autore: Ufficio Tecnico	Data: 16/06/03	Codice Progetto: SLADKDIP5K2	
Nome PC in Rete:	Revisione: 2.0	Nome Parte:	
File/Cartella:	Autorizzazione:	Codice: SLADKDIP5K2	
Scala: /	Materiale: /	Trattamento: /	Profilo: /



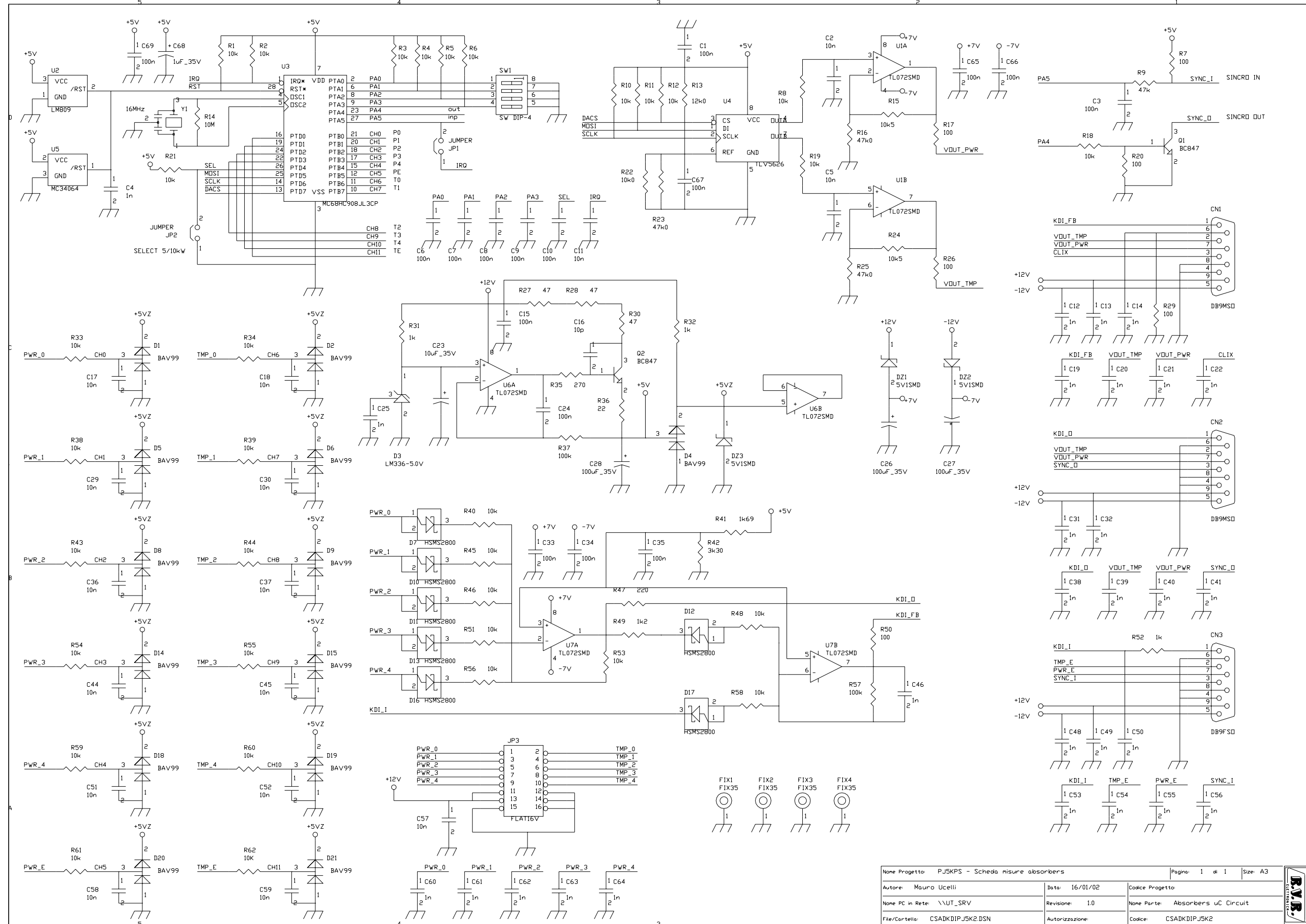

None Progetto: PJ5KPS - Scheda misure absorbers		Pagina: 1 di 1		Size: A3
Autore: Mauro Ucelli	Data: 16/01/02	Codice Progetto		
Nome PC in Rete: \\UT_SRV	Revisione: 1.0	None Parte: Absorbers uC Circuit		
File/Cartella: CSADKDIPJ5K2.DSN	Autorizzazione:	Codice: CSADKDIPJ5K2		



## LISTA MATERIALI

Item	Quantity	Reference	Part
1	2	CN1, CN2	DB9MSO
2	1	CN3	DB9FSO
3	16	C1, C3, C6, C7, C8, C9, C10, C15, C24, C33, C34, C35, C65, C66, C67, C69	100n
4	16	C2, C5, C11, C17, C18, C29, C30, C36, C37, C44, C45, C51, C52, C57, C58, C59	10n
5	31	C4, C12, C13, C14, C19, C20, C21, C22, C25, C31, C32, C38, C39, C40, C41, C46, C48, C49, C50, C53, C54, C55, C56, C60, C61, C62, C63, C64	1n
6	1	C16	10p
7	1	C23	10uF 35V
8	3	C26, C27, C28	100uF 35V
9	1	C68	1uF 35V
10	3	DZ1, DZ2, DZ3	5V1SMD
11	13	D1, D2, D4, D5, D6, D8, D9, D14, D15, D18, D19, D20, D21	BAV99
12	1	D3	LM336-5.0V
13	7	D7, D10, D11, D12, D13, D16, D17	SMS2800
14	4	FIX1, FIX2, FIX3, FIX4	FIX35
15	2	JP2, JP1	JUMPER
16	1	JP3	FLAT16V
17	2	Q2, Q1	BC847
18	33	R1, R2, R3, R4, R5, R6, R8, R10, R11, R12, R18, R19, R21, R33, R34, R38, R39, R40, R43, R44, R45, R46, R48, R51, R53, R54, R55, R56, R58, R59, R60, R61, R62	10k
19	6	R7, R17, R20, R26, R29, R50	100
20	1	R9	47k
21	1	R13	12k0
22	1	R14	10M
23	2	R15, R24	10k5
24	3	R16, R23, R25	47k0
25	1	R22	10k0
26	3	R27, R28, R30	47
27	3	R31, R32, R52	1k
28	1	R35	270
29	1	R36	22
30	2	R57, R37	100k
31	1	R41	1k69
32	1	R42	3k30
33	1	R47	220
34	1	R49	1k2
35	1	SW1	SW DIP-4
36	3	U1, U6, U7	TL072SMD
37	1	U2	LM809
38	1	U3	MC68HC908JL3CP
39	1	U4	TLV5626
40	1	U5	MC34064
41	1	Y1	

ADATTATORE CPU/BIAS MODULO R.F.

SLADBSPJ5KM2

PIANO DI MONTAGGIO

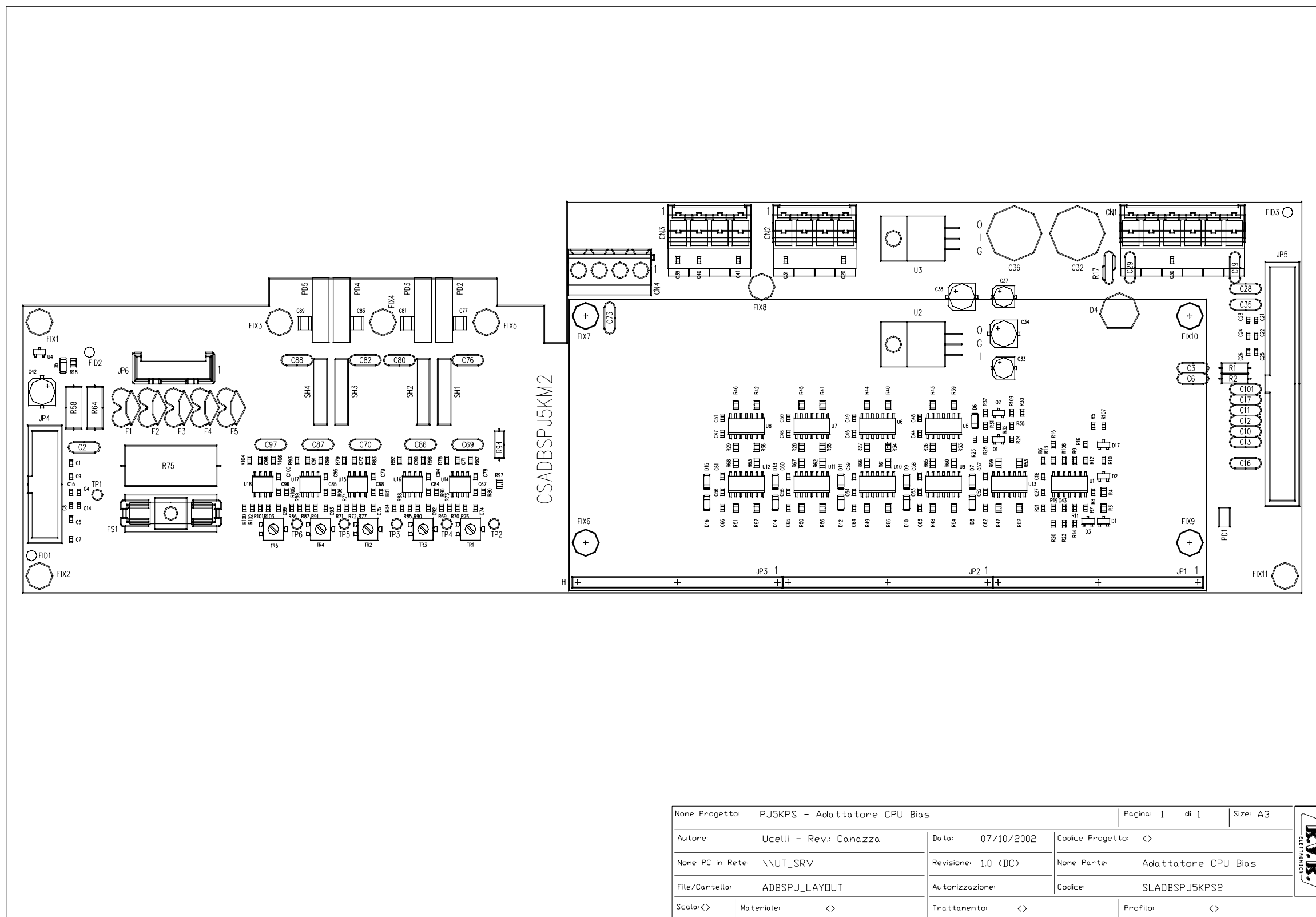

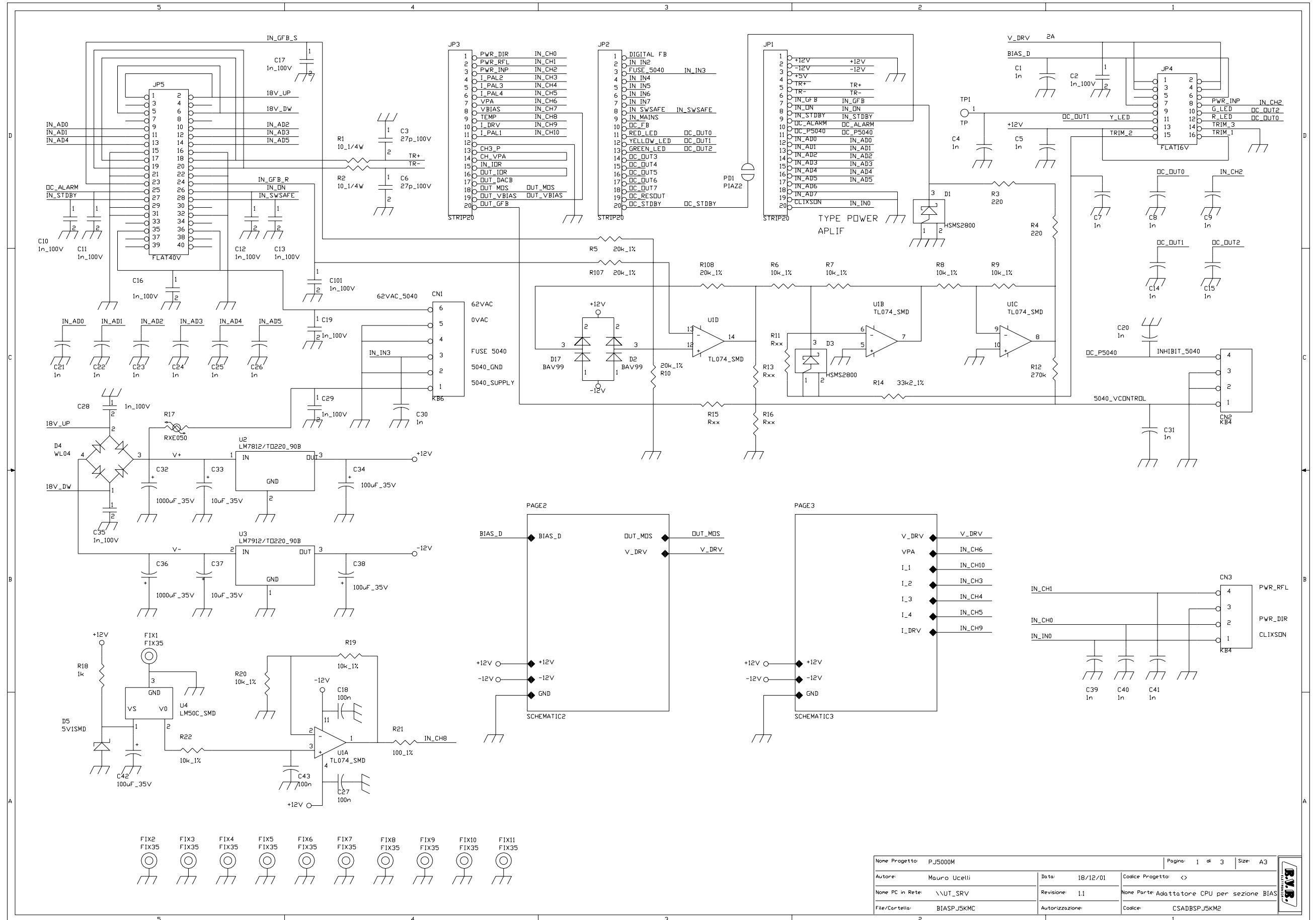

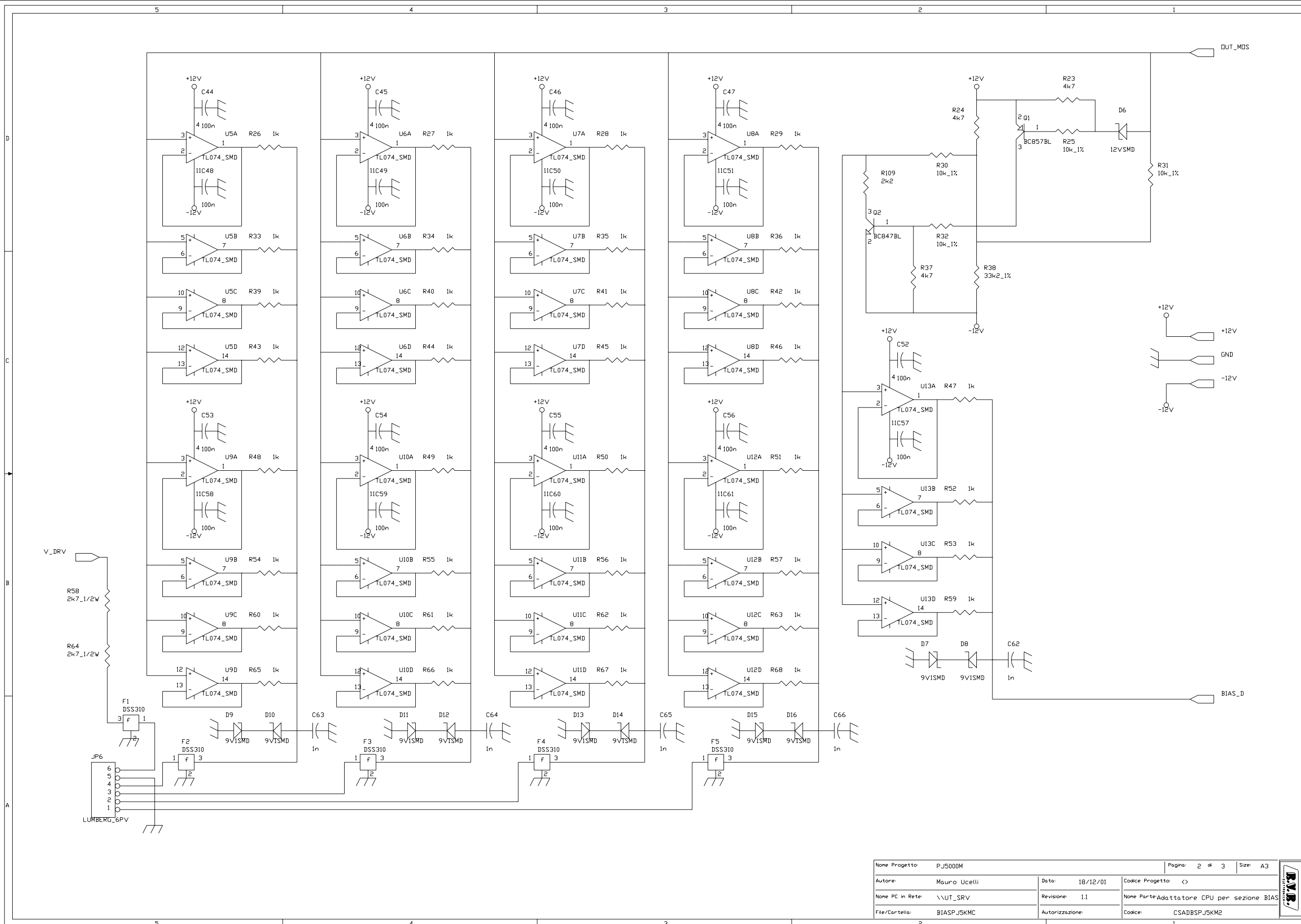

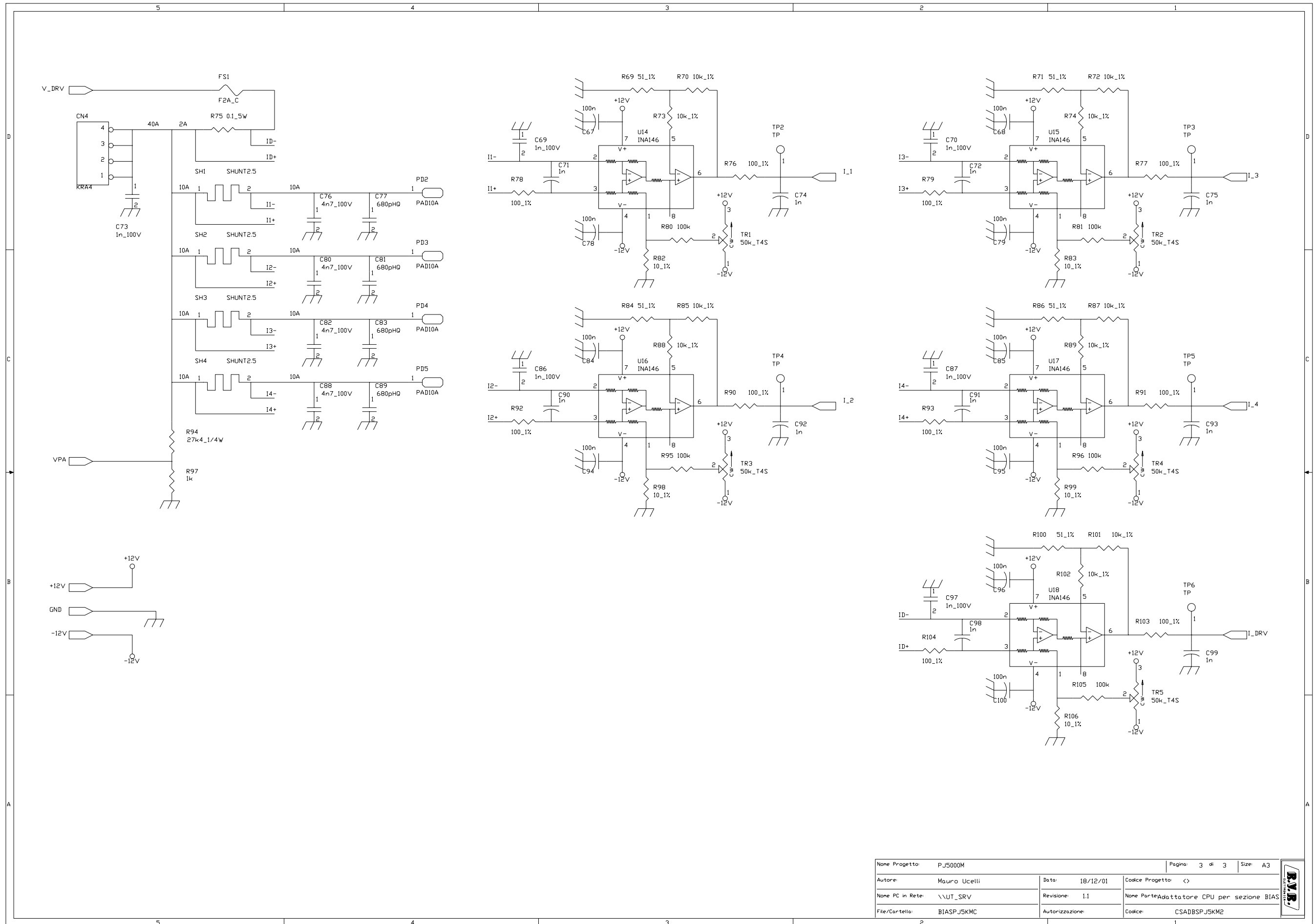

## Lista Materiali

Item	Quantity	Reference	Part
1	1	CN1	KB6
2	2	CN3, CN2	KB4
3	1	CN4	KRA4
4	35	C1, C4, C5, C7, C8, C9, C14, C15, C20, C21, C22, C23, C24, C25, C26, C30, C31, C39, C40, C41, C62, C63, C64, C65, C66, C71, C72, C74, C75, C90, C91, C92, C93, C98, C99	1n
5	18	C2, C10, C11, C12, C13, C16, C17, C19, C28, C29, C35, C69, C70, C73, C86, C87, C97, C101	1n_100V
6	2	C6, C3	27p 100V
7	31	C18, C27, C43, C44, C45, C46, C47, C48, C49, C50, C51, C52, C53, C54, C55, C56, C57, C58, C59, C60, C61, C67, C68, C78, C79, C84, C85, C94, C95, C96, C100	100n
8	2	C36, C32	1000uF 35V
9	2	C33, C37	10uF 35V
10	3	C34, C38, C42	100uF 35V
11	4	C76, C80, C82, C88	4n7 100V
12	4	C77, C81, C83, C89	680pHQ
13	2	D3, D1	HSMS2800
14	2	D2, D17	BAV99
15	1	D4	WL04
16	1	D5	5V1SMD
17	1	D6	12VSMD
18	10	D7, D8, D9, D10, D11, D12, D13, D14, D15, D16	9V1SMD
19	11	FIX1, FIX2, FIX3, FIX4, FIX5, FIX6, FIX7, FIX8, FIX9, FIX10, FIX11	FIX35
20	1	FS1	F2A_C
21	5	F1, F2, F3, F4, F5	DSS310
22	3	JP1, JP2, JP3	STRIP20
23	1	JP4	FLAT16V
24	1	JP5	FLAT40V
25	1	JP6	LUMBERG 6PV
26	1	PD1	PIAZ2
27	4	PD2, PD3, PD4, PD5	PAD10A
28	1	Q1	BC857BL

Item	Quantity	Reference	Part
29	1	Q2	BC847BL
30	2	R1, R2	10 1/4W
31	2	R3, R4	220
32	4	R5, R10, R107, R108	20k 1%
33	21	R6, R7, R8, R9, R19, R20, R22, R25, R30, R31, R32, R70, R72, R73, R74, R85, R87, R88, R89, R101, R102	10k_1%
34	4	R11, R13, R15, R16	Rxx
35	1	R12	270k
36	2	R14, R38	33k2 1%
37	1	R17	RXE050
38	38	R18, R26, R27, R28, R29, R33, R34, R35, R36, R39, R40, R41, R42, R43, R44, R45, R46, R47, R48, R49, R50, R51, R52, R53, R54, R55, R56, R57, R59, R60, R61, R62, R63, R65, R66, R67, R68, R97	1k
39	11	R21, R76, R77, R78, R79, R90, R91, R92, R93, R103, R104	100_1%
40	3	R23, R24, R37	4k7
41	2	R64, R58	2k7 1/2W
42	5	R69, R71, R84, R86, R100	51 1%
43	1	R75	0.1 5W
44	5	R80, R81, R95, R96, R105	100k
45	5	R82, R83, R98, R99, R106	10 1%
46	1	R94	27k4 1/4W
47	1	R109	2k2
48	4	SH1, SH2, SH3, SH4	SHUNT2.5
49	6	TP1, TP2, TP3, TP4, TP5, TP6	TP
50	5	TR1, TR2, TR3, TR4, TR5	50k T4S
51	10	U1, U5, U6, U7, U8, U9, U10, U11, U12, U13	TL074 SMD
52	1	U2	LM7812/TO220 90B
53	1	U3	LM7912/TO220 90B
54	1	U4	LM50C SMD
55	5	U14, U15, U16, U17, U18	INA146

DRIVER MODULO R.F.

SLDRVRFPJ5M

PIANO DI MONTAGGIO

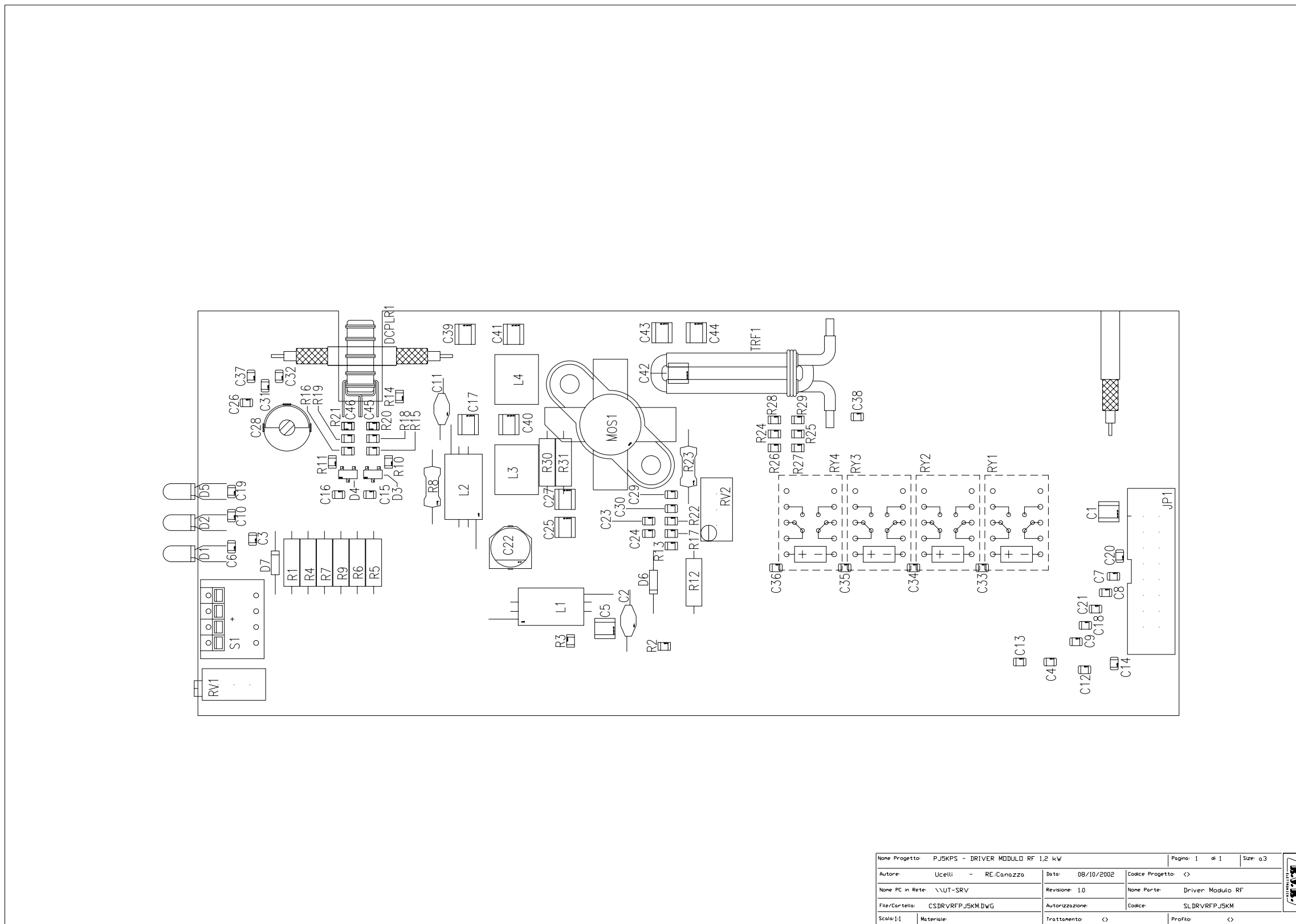

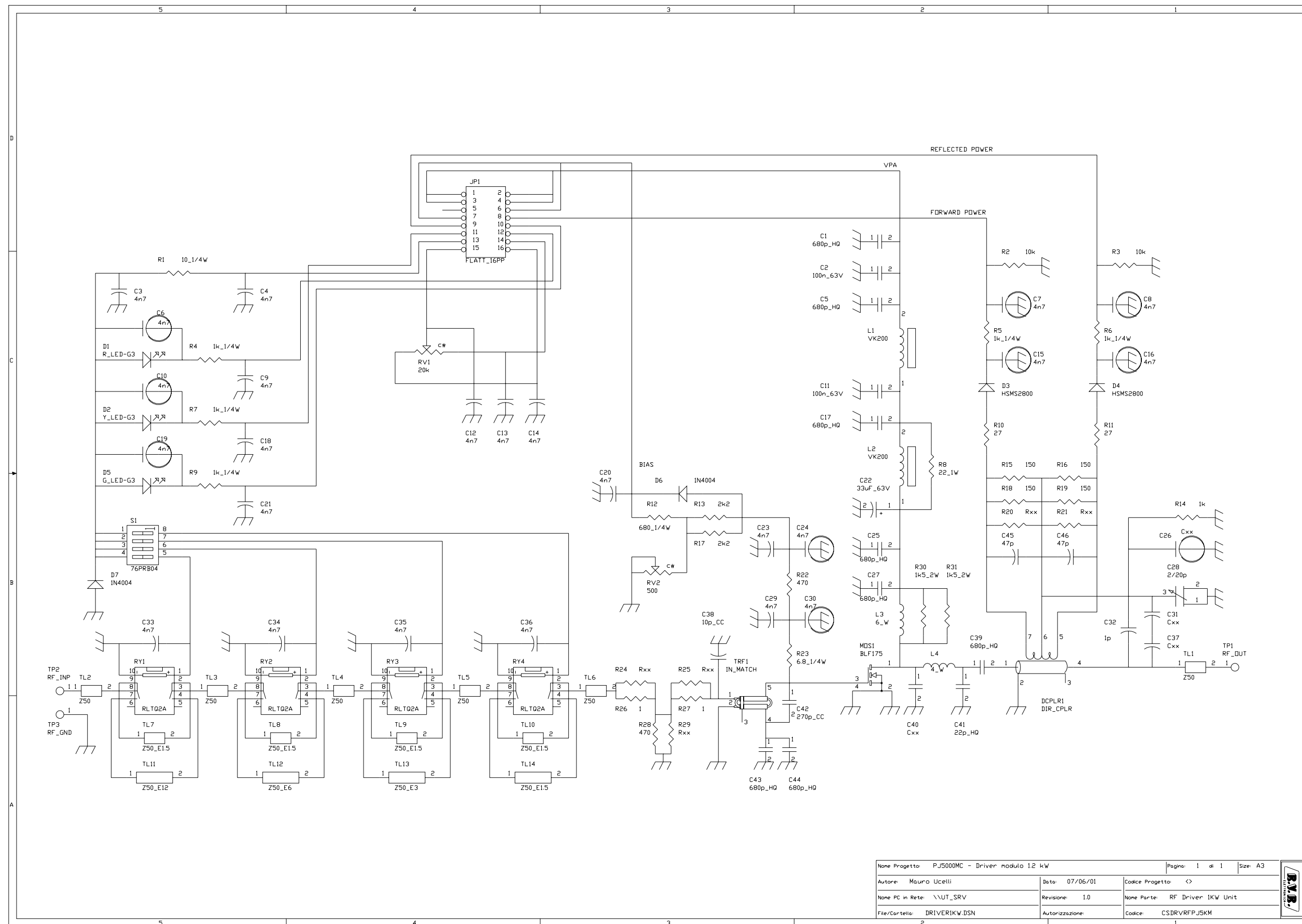

None Progetto: PJ5000MC - Driver modulo 1.2 kW		Pagina: 1 di 1		Size: A3
Autore: Mauro Ucelli	Data: 07/06/01	Codice Progetto: <>		
None PC in Rete: \\UT_SRV	Revisione: 1.0	None Parte: RF Driver 1KW Unit		
File/Cartella: DRIVERIKW.DSN	Autorizzazione:	Codice: CSDRVRF PJ5KM		



## Lista Materiali

Item	Quantity	Reference	Part
1	8	C1, C5, C17, C25, C27, C39, C43, C44	680p_HQ
2	2	C11, C2	100n 63V
3	24	C3, C4, C6, C7, C8, C9, C10, C12, C13, C14, C15, C16, C18, C19, C20, C21, C23, C24, C29, C30, C33, C34, C35, C36	4n7
4	1	C22	33uF 63V
5	4	C26, C31, C37, C40	Cxx
6	1	C28	2/20p
7	1	C32	1p
8	1	C38	10p CC
9	1	C41	22p HQ
10	1	C42	270p CC
11	2	C45, C46	47p
12	1	DCPLR1	DIR CPLR
13	1	D1	R LED-G3
14	1	D2	Y LED-G3
15	2	D3, D4	HSMS2800
16	1	D5	G LED-G3
17	2	D7, D6	1N4004
18	1	JP1	FLATT 16PP
19	2	L2, L1	VK200
20	1	L3	6 W
21	1	L4	4 W
22	1	MOS1	BLF175
23	1	RV1	20k
24	2	RV2, R14	1k
25	4	RY1, RY2, RY3, RY4	RLTQ2A
26	1	R1	10 1/4W
27	2	R2, R3	10k
28	5	R4, R5, R6, R7, R9	1k 1/4W
29	1	R8	22 1W
30	2	R11, R10	27
31	1	R12	680 1/4W
32	2	R13, R17	2k2
33	4	R15, R16, R18, R19	150
34	5	R20, R21, R24, R25, R29	Rxx
35	2	R22, R28	470
36	1	R23	6.8 1/4W
37	2	R26, R27	1
38	2	R31, R30	1k5 2W
39	1	S1	76PRB04
40	6	TL1, TL2, TL3, TL4, TL5, TL6	Z50
41	5	TL7, TL8, TL9, TL10, TL14	Z50 E1.5
42	1	TL11	Z50 E12
43	1	TL12	Z50 E6
44	1	TL13	Z50 E3
45	1	TP1	RF OUT
46	1	TP2	RF INP
47	1	TP3	RF GND
48	1	TRF1	IN MATCH

ALIMENTATORE SWITCHING MODULO R.F.

PSSW5040

PIANO DI MONTAGGIO

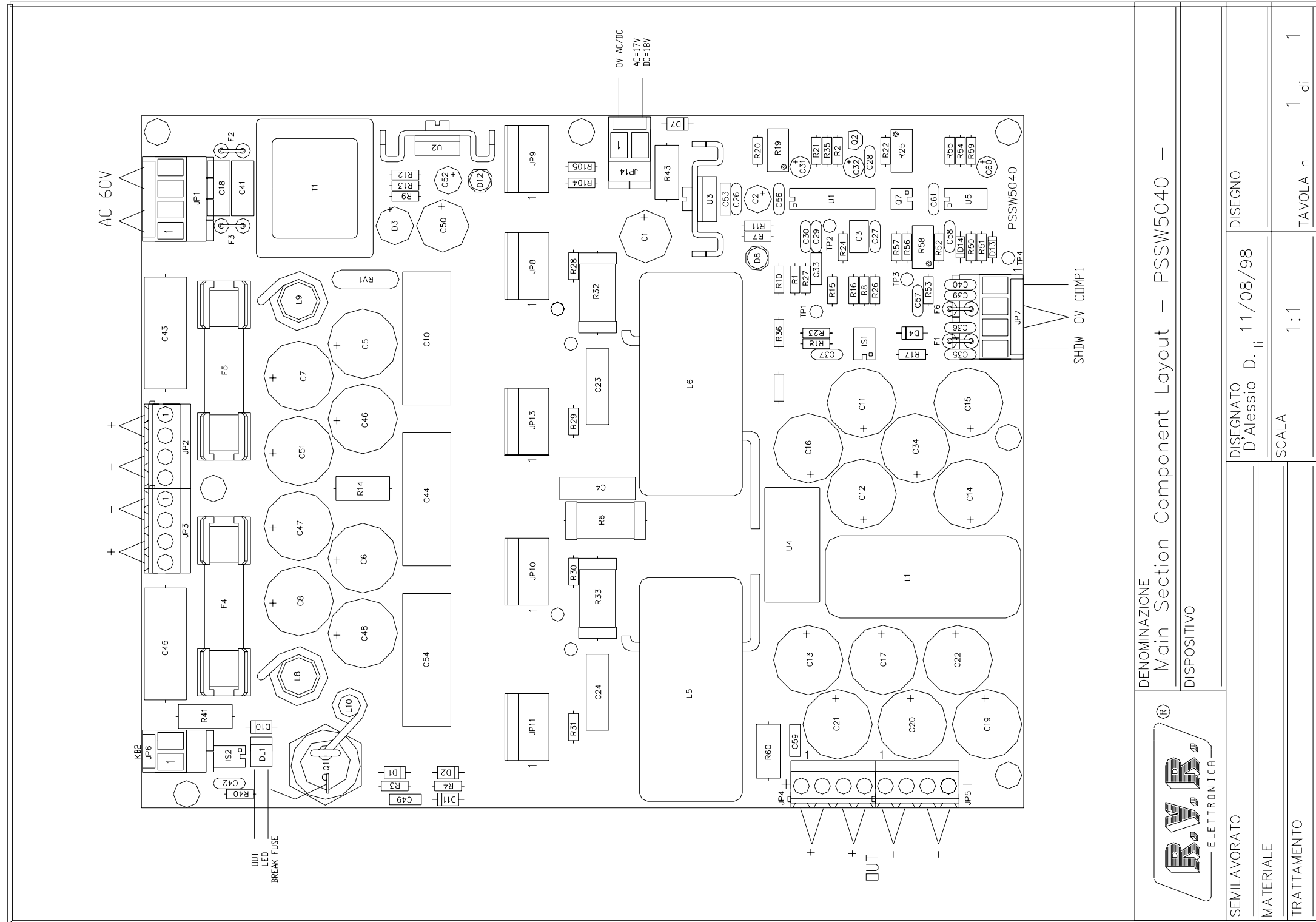

DENOMINAZIONE  
Main Section Component Layout - PSSW5040 -  
DISPOSITIVO



SEMILAVORATO  
DISEGNATO D'Alessio D. ii 11/08/98 DISEGNO

MATERIALE  
SCALA 1:1 TAVOLA n 1 di 1

TRATTAMENTO

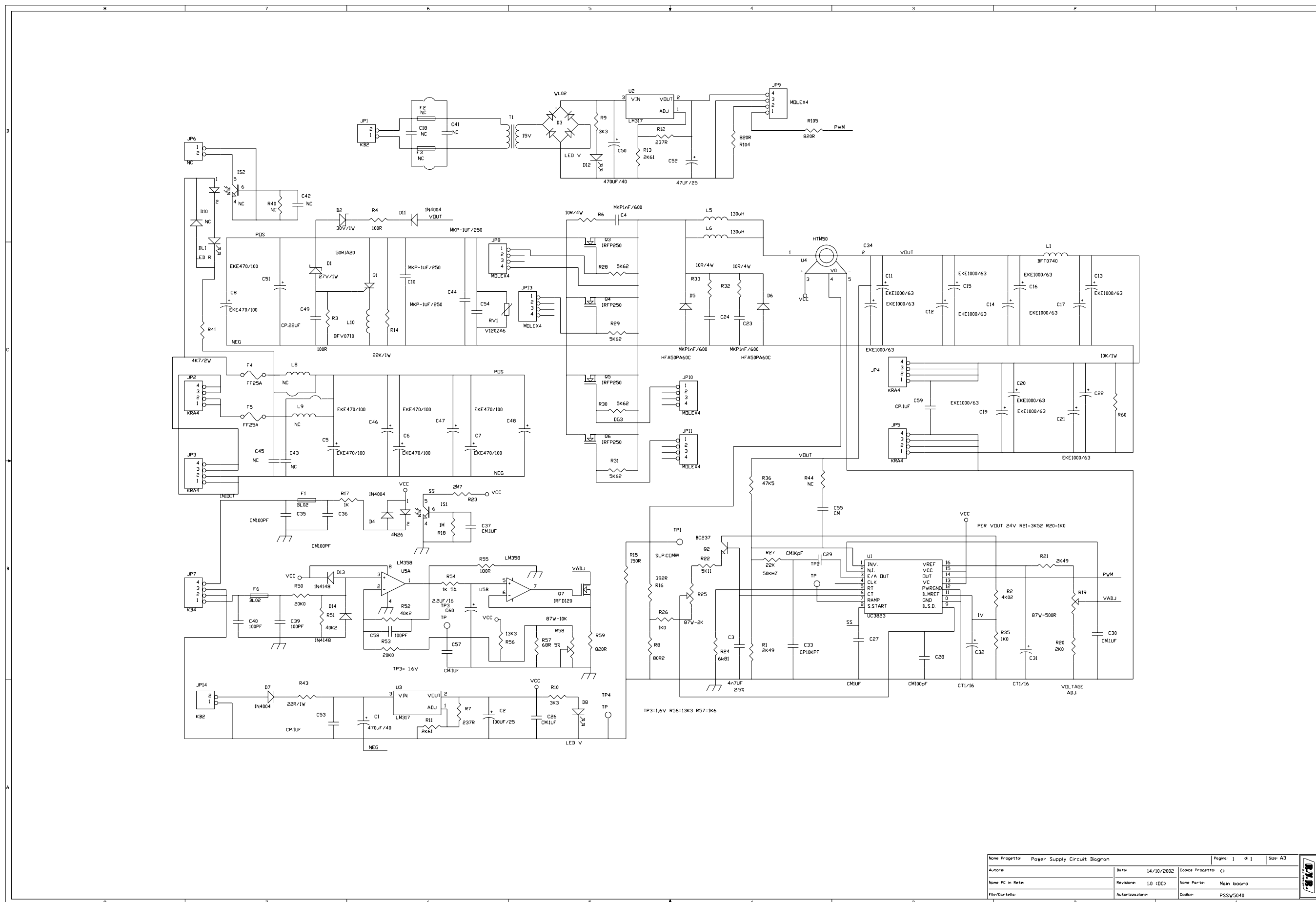

Nome Progetto: Power Supply Circuit Diagram	Page: 1	# 1	Size: A3
Autore:	Data: 14/10/2002	Code Progetto: <	
Nome PC in Rete:	Revisione: 1.0 (DC)	Nome Parte: Main board	
File/Cartella:	Autorizzazione:	Code: PSSW5040	

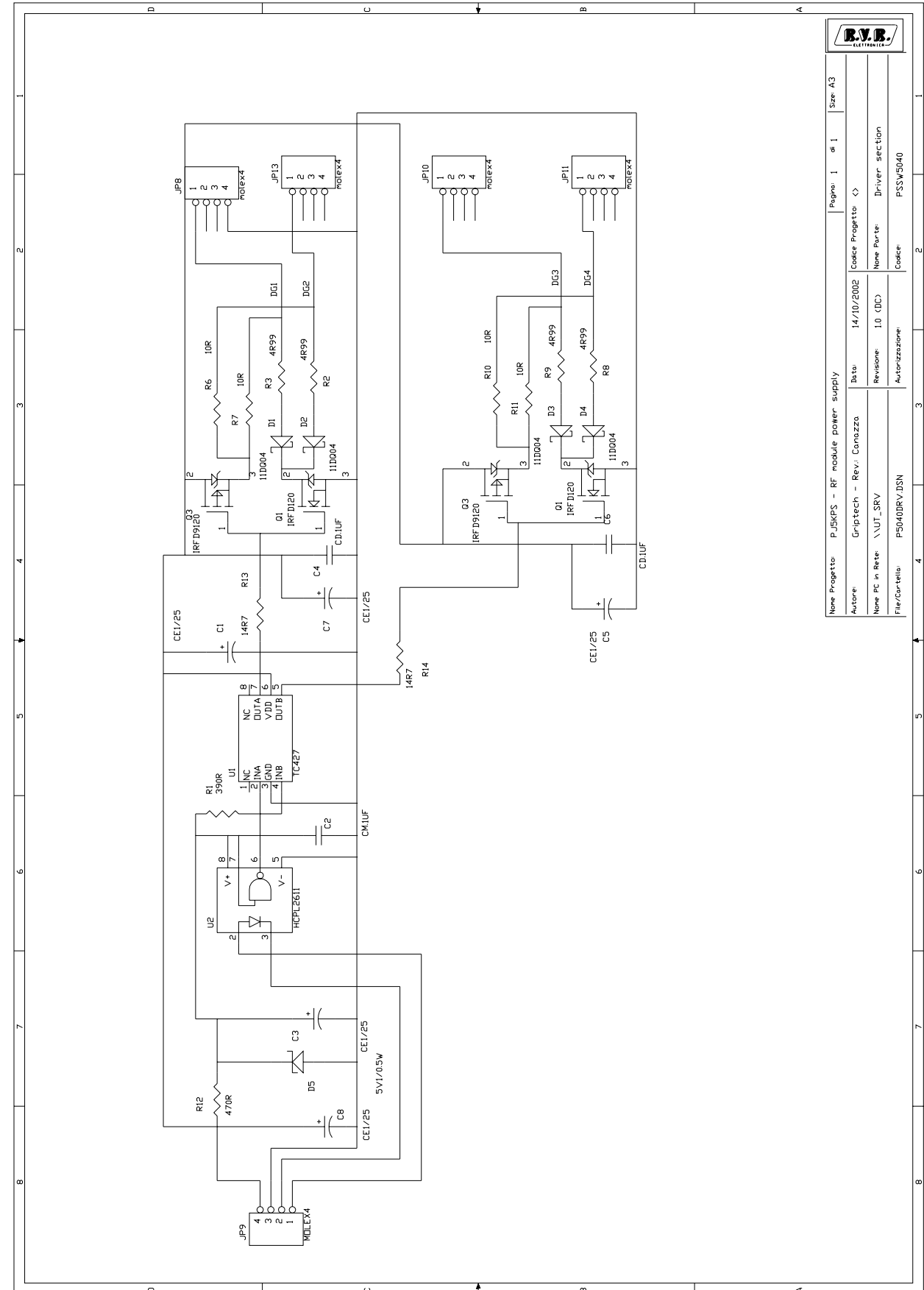
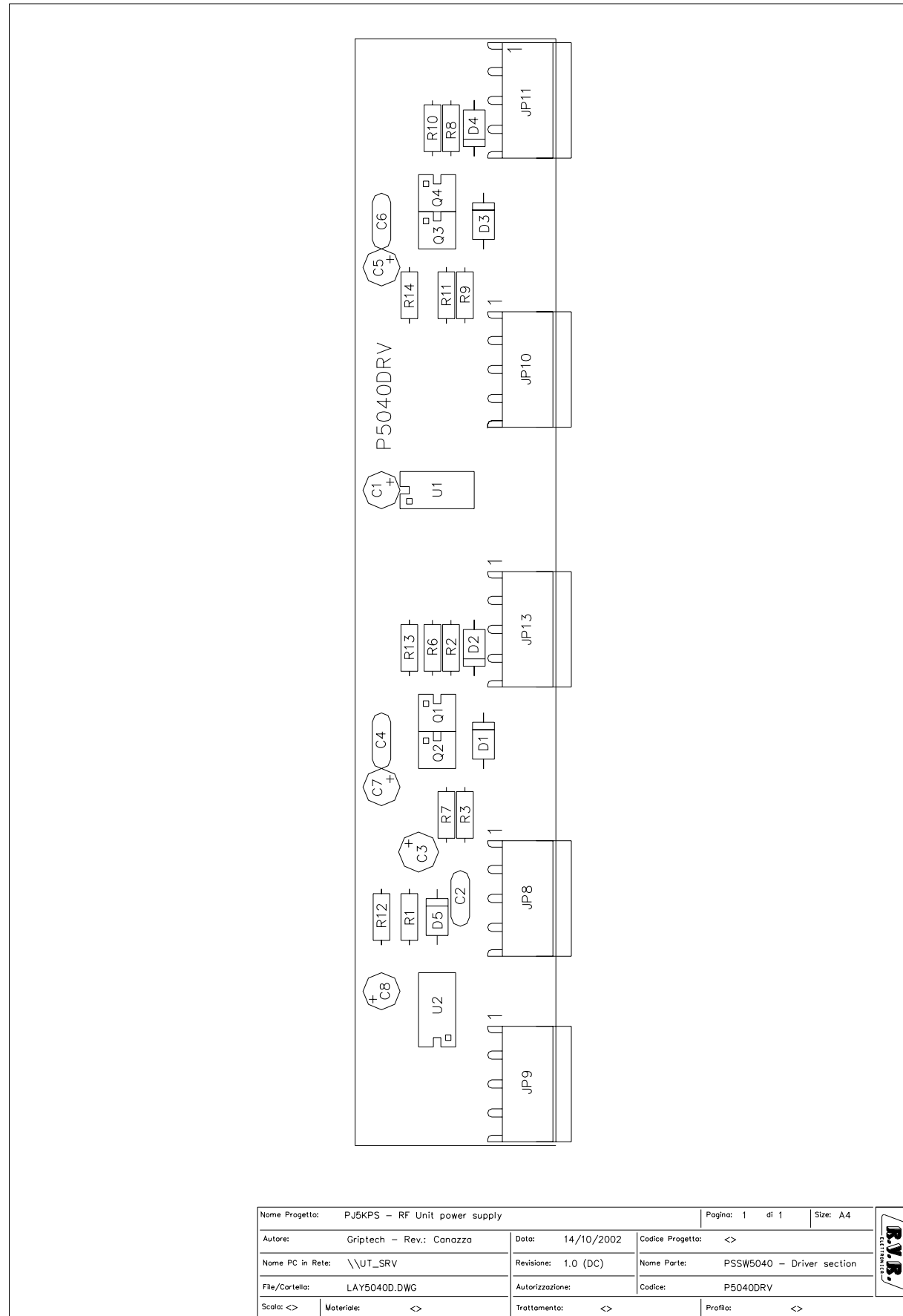

## Lista Materiali

Item	Quantity	Reference	Part
1	2	Q7, Q1	IRFD120
2	4	Q3, Q4, Q5, Q6	IRFP250
3	1	Q3	IRFD9120
4	2	C1, C50	470UF/40
5	5	C1, C3, C5, C7, C8	CE1/25
6	2	C2, C1	EYS4700/100
7	1	C2	100UF/25
8	5	C2, C26, C30, C37, C57	CM.1UF
9	10	C3, C4, C5, C6, C7, C8, C46, C47, C48, C51	EKE470/100
10	1	C3	4n7UF
11	3	C4, C23, C24	MKP1nF/600
12	2	C4, C6	CD.1UF
13	1	C7	CA1/250
14	3	C10, C44, C54	MKP-1UF/250
15	12	C11, C12, C13, C14, C15, C16, C17, C19, C20, C21, C22, C34	EKE1000/63
16	11	IS2, F2, F3, L8, L9, D10, C18, R40, C42, R44, C45	NC
17	1	C27	CM1UF
18	3	C28, C35, C36	CM100PF
19	1	C29	CM1KpF
20	2	C31, C32	CT1/16
21	1	C33	CP10KPF
22	3	C39, C40, C58	100PF
23	3	JP6, C41, C43	NC
24	1	C49	CP.22UF
25	1	C52	47UF/25
26	2	C53, C59	CP.1UF
27	1	C55	CM
28	1	C60	2.2UF/16
29	1	DL1	LED R
30	4	D1, D2, D3, D4	11DQ04
31	1	D1	27V/1W
32	2	D1, D2	40EPS08
33	1	D2	30V/1W
34	1	D3	WL02
35	3	D4, D7, D11	1N4004
36	2	D6, D5	HFA50PA60C
37	1	D5	5V1/0.5W
38	2	D12, D8	LED V
39	2	D13, D14	1N4148
40	2	F6, F1	BL02
41	2	F5, F4	FF25A
42	1	IS1	4N26
43	2	JP1, JP14	PHOENIX2
44	1	JP1	KRA10
45	4	JP2, JP3, JP4, JP5	KRA4
46	1	JP7	KB4
47	5	JP8, JP9, JP10, JP11, JP13	MOLEX4
48	1	JP12	JUMPER2
49	1	L1	BFV0720
50	1	L1	BFT0740
51	2	L5, L6	130uH
52	1	L10	BFV0710

Item	Quantity	Reference	Part
53	1	Q1	50RIA20
54	1	Q2	BC237
55	1	RV1	V120ZA6
56	1	R1	22K
57	2	R1, R21	2K49
58	1	R1	390R
59	1	R2	4K02
60	4	R2, R3, R8, R9	4R99
61	2	R3, R4	100R
62	4	R6, R7, R10, R11	10R
63	3	R6, R32, R33	10R/4W
64	2	R7, R12	237R
65	1	R8	80R2
66	2	R9, R10	3K3
67	2	R11, R13	2K61
68	1	R12	470R
69	2	R14, R13	14R7
70	1	R14	22K/1W
71	1	R15	150R
72	1	R16	392R
73	1	R17	1K
74	1	R18	1M
75	1	R19	87W-500R
76	1	R20	2K0
77	1	R22	5K11
78	1	R23	2M7
79	1	R24	6k81
80	1	R25	87W-2K
81	2	R35, R26	1K0
82	1	R27	22K
83	4	R28, R29, R30, R31	5K62
84	1	R36	47K5
85	1	R41	4K7/2W
86	1	R43	22R/1W
87	2	R50, R53	20K0
88	2	R52, R51	40K2
89	1	R54	1K 5%
90	1	R55	180R
91	1	R56	13K3
92	1	R57	68R 5%
93	1	R58	87W-10K
94	3	R59, R104, R105	820R
95	1	R60	10K/1W
96	4	TP1, TP2, TP3, TP4	TP
97	1	T1	15V
98	1	U1	TC427
99	1	U1	UC3823
100	1	U2	HCPL2611
101	2	U3, U2	LM317
102	1	U4	HTM50
103	1	U5	LM358

**CIRCUITO 380 VOLT**  
3FRCKPJ10KMC

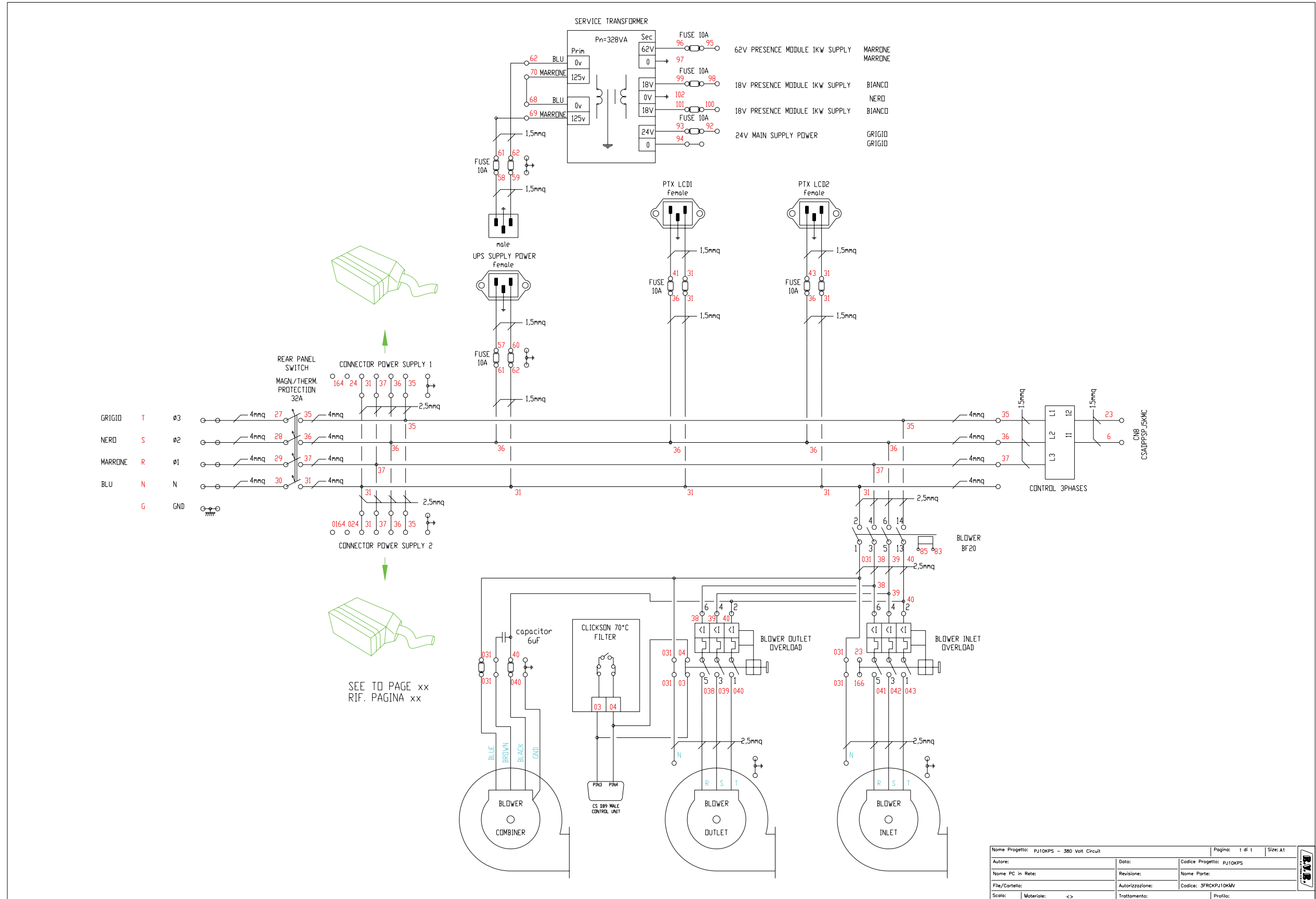

CIRCUITO RETTIFICATORE CARRELLO 380 VOLT

3FRECTPJ10KM

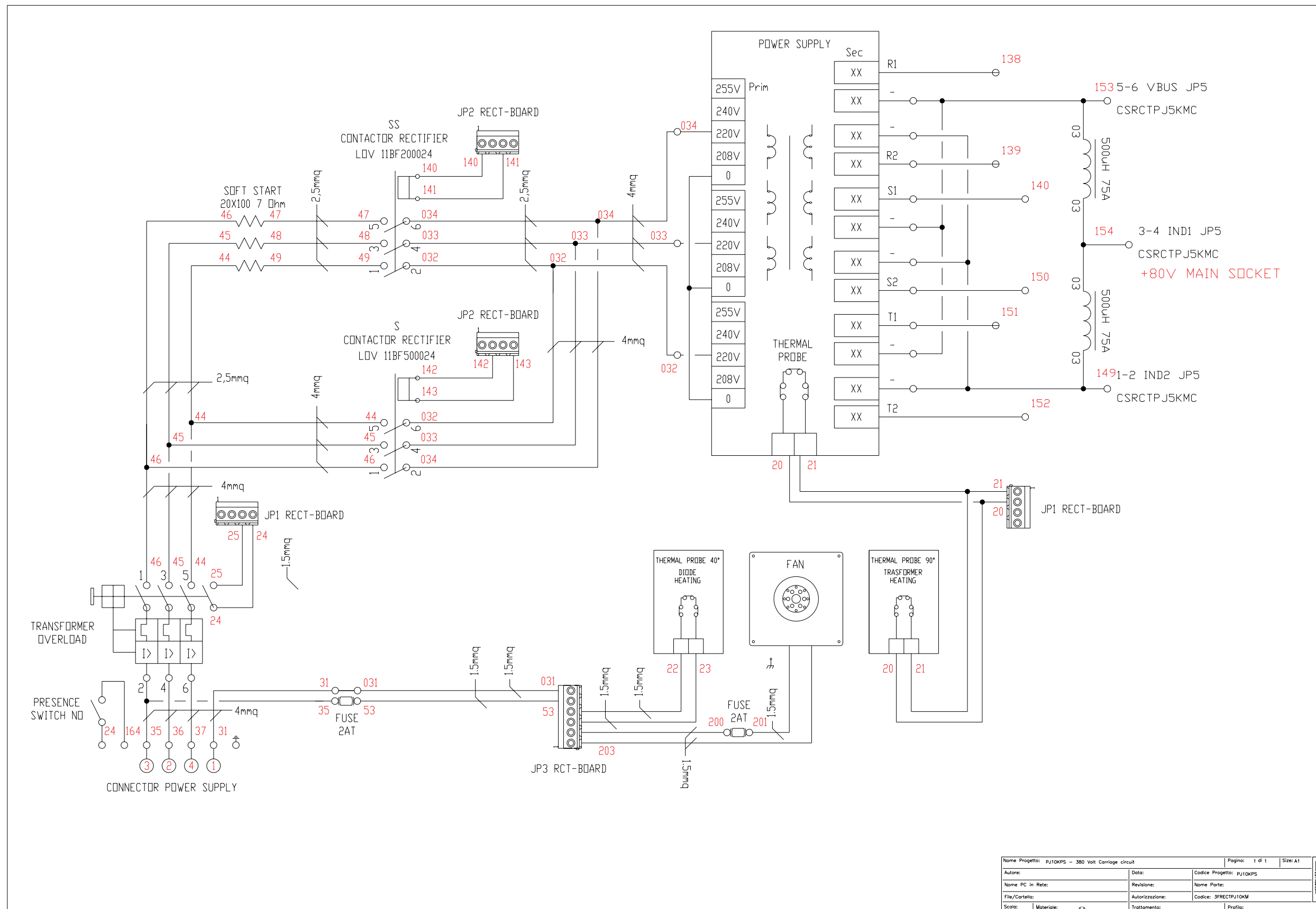

Nome Progetto: PJ10KPS - 380 Volt Carriage circuit		Pagina: 1 di 1	Size: A1
Autore:	Data:	Codice Progetto: PJ10KPS	
Nome PC in Rete:	Revisione:	Nome Parte:	
File/Cartella:	Autorizzazione:	Codice: 3FRECTPJ10KM	
Scala:	Materiale: <>	Trattamento:	Profilo:

CIRCUITO BASSA TENSIONE E SEGNALI

LOWTENPJ10KM

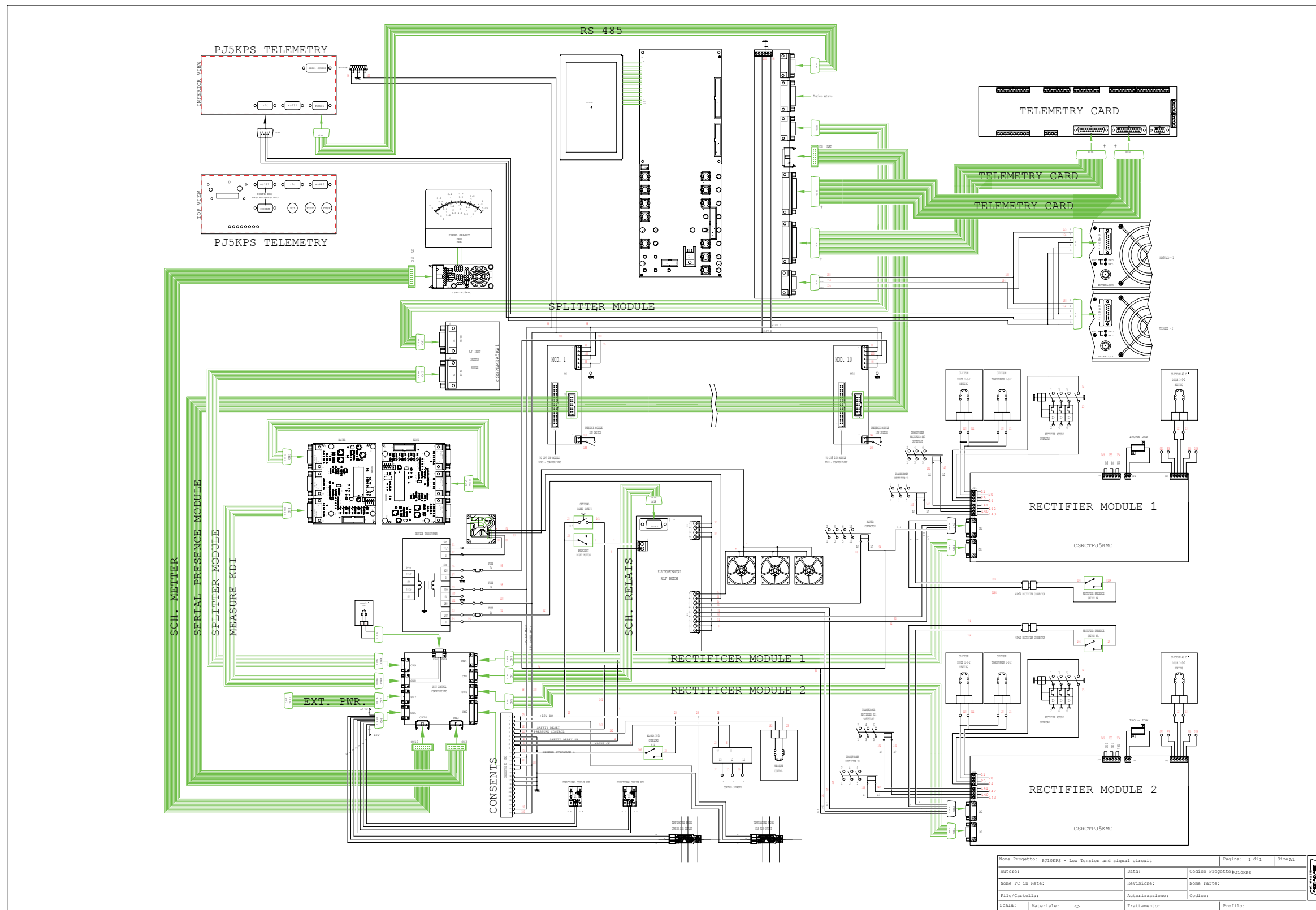



**PJ10KPS – Appendice Tecnica**

© Copyright 2005  
R.V.R. Elettronica S.p.A.  
Via del Fonditore 2/2c – 40138 Bologna Italia  
Telephone: +39 051 6010506  
Fax: +39 051 6011104  
E-mail: [info@rvr.it](mailto:info@rvr.it)  
Web: [www.rvr.it](http://www.rvr.it)

All right reserved  
Printed and bound in Italy. No part of this manual may be reproduced, memorized or transmitted in any form or by any means, electronic or mechanic, including photocopying, recording or by any information storage and retrieval system, without the permission of the copyright owner.