

PJ300C-LCD

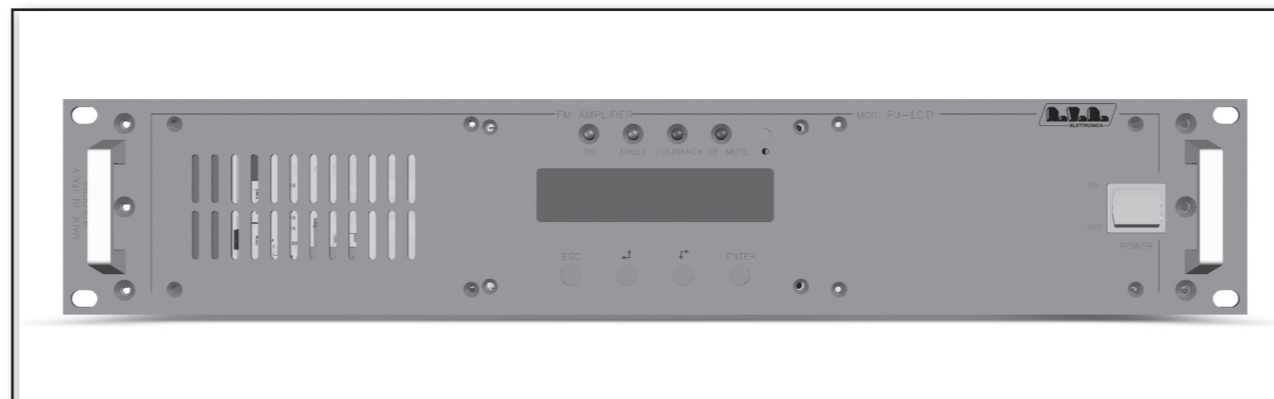

User Manual Volume 2: Technical Appendix

Appendix A Piani di montaggio, schemi elettrici, liste componenti / *Component layouts, schematics, bills of material*

Questa parte del manuale contiene i dettagli tecnici riguardanti la costruzione delle singole schede componenti il PJ300C-LCD. L'appendice è composta dalle seguenti sezioni:

This part of the manual contains the technical details about the different boards of the PJ300C-LCD. This appendix is composed of the following sections:

Description	RVR Code	Vers.	Page
Interlock Output Interface	SL123IN1001	1.0	1
Control Board	SL045DR1101	1.0	3
Power Amplifier	SL123RF1001	1.0	5
Panel Board	SL007PC2002	1.1	8
Power Supply	PSL600	1.0	10
Telemetry Board	SLTLMTXLCD03	2.1	19

Document History

Date	Version	Reason	Code	Editor
15/12/2006	1.0	First Release	/	J.H. Berti

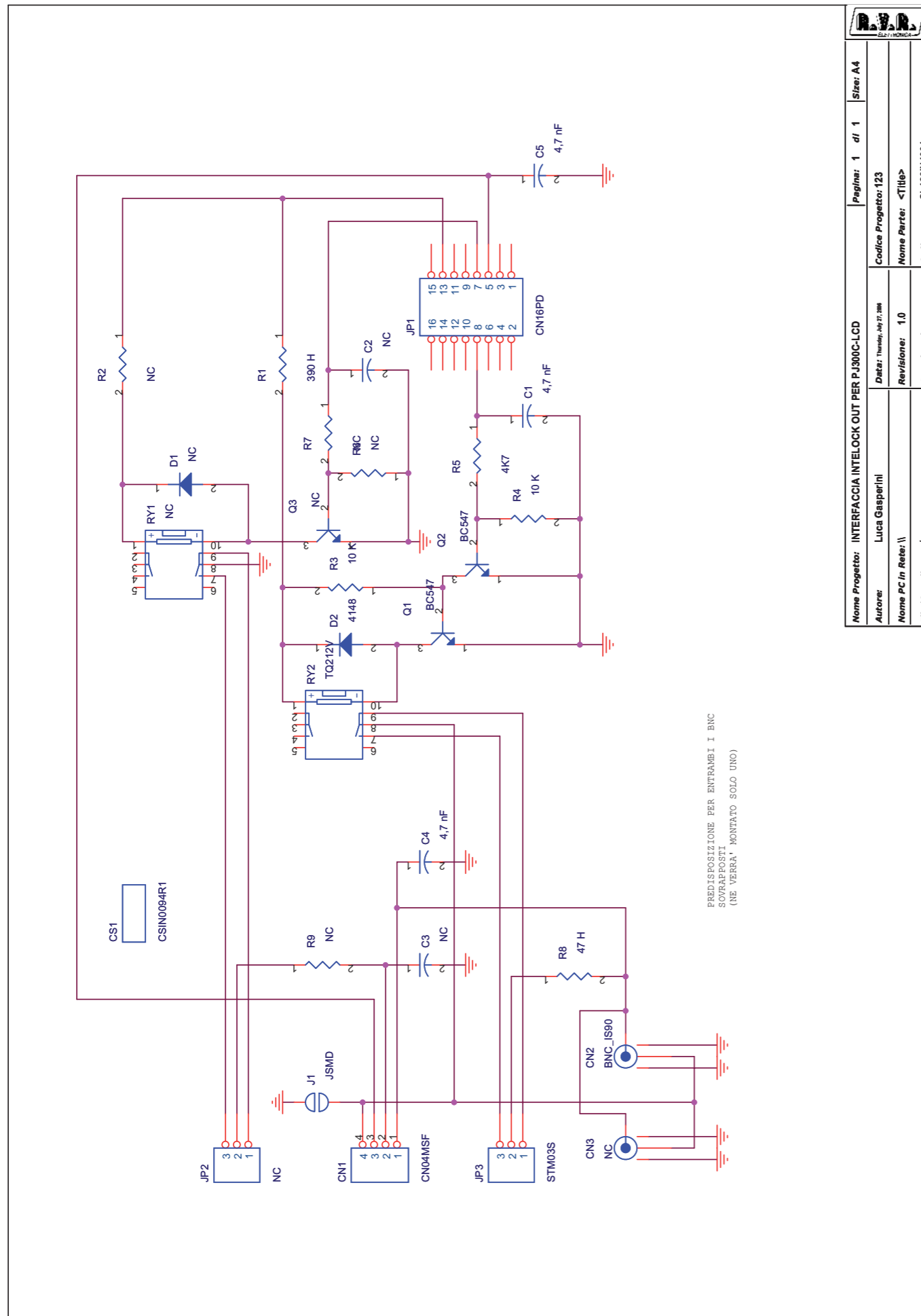

Nome Progetto: INTERFACCIA INTELOCK OUT PER PJ300C-LCD		Pagina: 1 di 1		Size: A4	
Autore: Luca Gasperini		Codice Progetto: 123			
Nome PC In Rete: \\		Revisione: 1.0		Nome Parte: <Title>	
File/Caratteri: /		Autorizzazione:		Codice: SL123IN1001	
Data: Thursday, 09/27/2006					

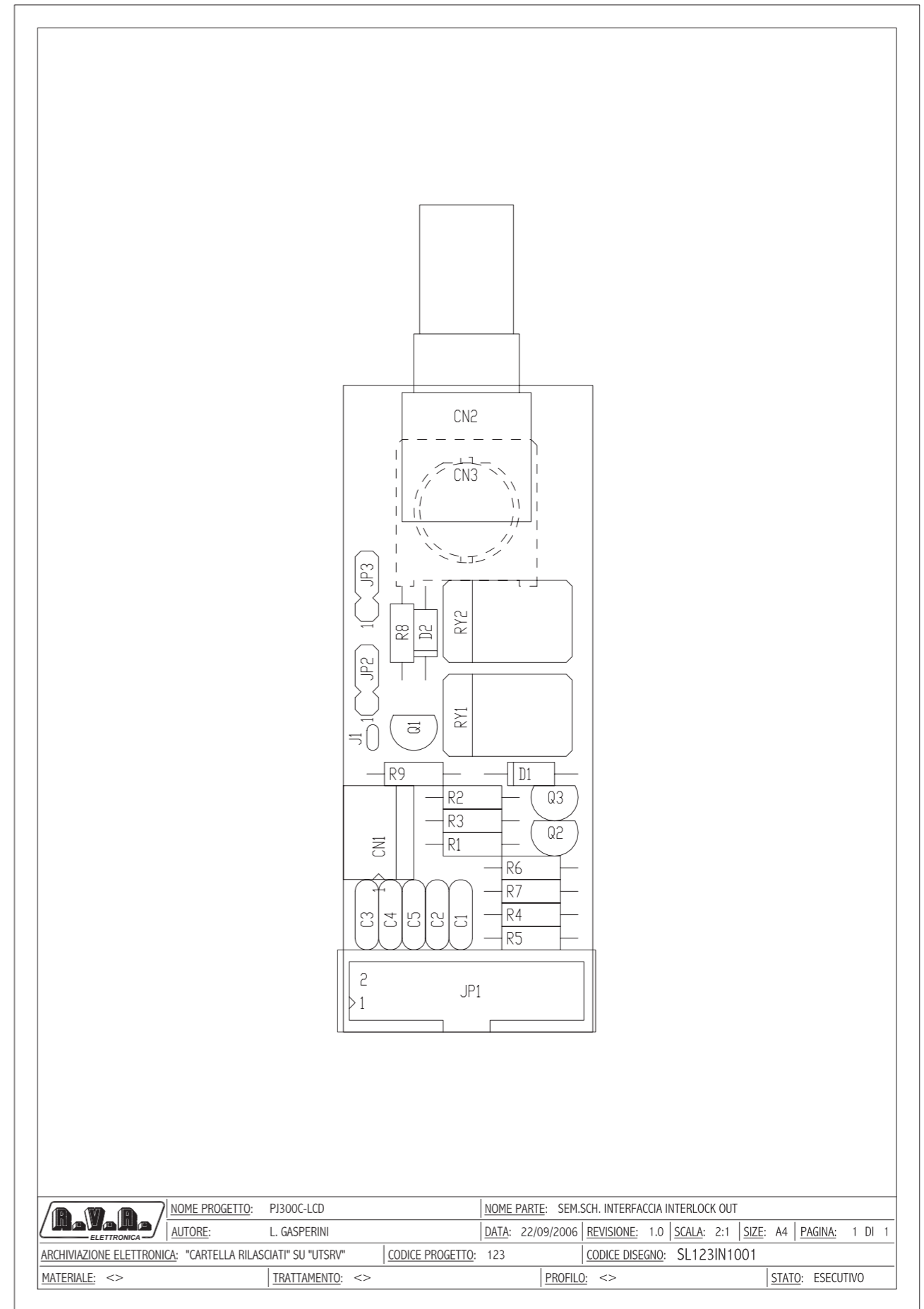

NOME PROGETTO: PJ300C-LCD		NOME PARTE: SEM.SCH. INTERFACCIA INTERLOCK OUT			
AUTORE: L. GASPERINI		DATA: 22/09/2006	REVISIONE: 1.0	SCALA: 2:1	SIZE: A4
ARCHIVIAZIONE ELETTRONICA: "CARTELLA RILASCIATI" SU "UTSRV"		CODICE PROGETTO: 123	CODICE DISEGNO: SL123IN1001		
MATERIALE: <>		TRATTAMENTO: <>		PROFILO: <>	STATO: ESECUTIVO

SL123IN1001

Scheda Interfaccia Interlock Out Revised: Thursday, July 27, 2006

SL123IN1001 Revision: 1.0

INTERFACCIA INTELOCK OUT PER PJ300C-LCD

123

Luca Gasperini

Item	Quantity	Reference	Part	{DESCRIPTION}
1	1	CN1	CN04MSF	STRIP M 4 PIN CNTSTM40SDA
2	1	CN2	BNC_IS90	BNC 90 CNTBNCFC SMA
3	11	RY1, D1, R2, JP2, C2, Q3, CN3, C3, R6, R7, R9	NC	
4	1	CS1	CSIN0094R1	CS CSIN0094R1
5	3	C1, C4, C5	4,7 nF	COND. CERAMICO CKM472KC600P
6	1	D2	4148	DIODO SILICIO DIS1N4148
7	1	JP1	CN16PD	CONN. 16 FLAT CS CNTMCS16A
8	1	JP3	STM03S	STRIP M 3 PIN CNTSTM40SDA
9	1	J1	JSMD	
10	2	Q1, Q2	BC547	NPN TRANSISTOR TRNBC547
11	1	RY2	TQ212V	RELAY 12 V 2VV RLD2V12V05AM
12	1	R1	390 H	RES 1/4 W RSM1/4F0390H
13	2	R3, R4	10 K	RES 1/4 W RSM1/4F0010K
14	1	R5	4K7	RES 1/4 W RSM1/4F004K7
15	1	R8	47 H	RES 1/4 W RSM1/4F0047H

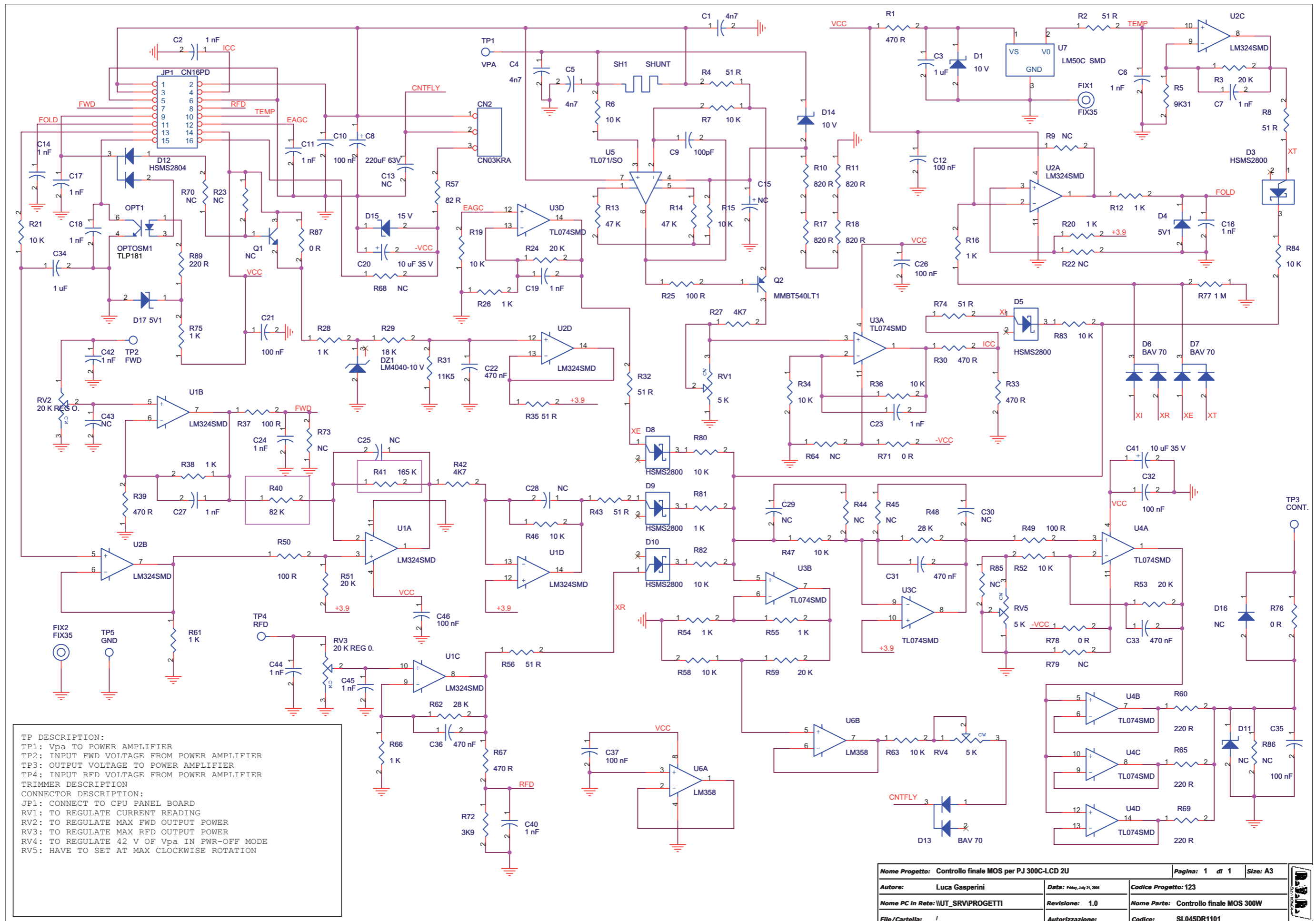

TP DESCRIPTION:
 TP1: Vpa TO POWER AMPLIFIER
 TP2: INPUT FWD VOLTAGE FROM POWER AMPLIFIER
 TP3: OUTPUT VOLTAGE TO POWER AMPLIFIER
 TP4: INPUT RFD VOLTAGE FROM POWER AMPLIFIER

TRIMMER DESCRIPTION:
 CONNECTOR DESCRIPTION:
 JP1: CONNECT TO CPU PANEL BOARD
 RV1: TO REGULATE CURRENT READING
 RV2: TO REGULATE MAX FWD OUTPUT POWER
 RV3: TO REGULATE MAX RFD OUTPUT POWER
 RV4: TO REGULATE 42 V OF Vpa IN PWR-OFF MODE
 RV5: HAVE TO SET AT MAX CLOCKWISE ROTATION

Nome Progetto: Controllo finale MOS per PJ 300C-LCD 2U		Pagina: 1 di 1	Size: A3
Autore: Luca Gasperini	Data: Friday, July 21, 2006	Codice Progetto: 123	
Nome PC in Rete: \\UT_SRV\PROGETTI	Revisione: 1.0	Nome Parte: Controllo finale MOS 300W	
File/Cartella: /	Autorizzazione:	Codice: SL045DR1101	

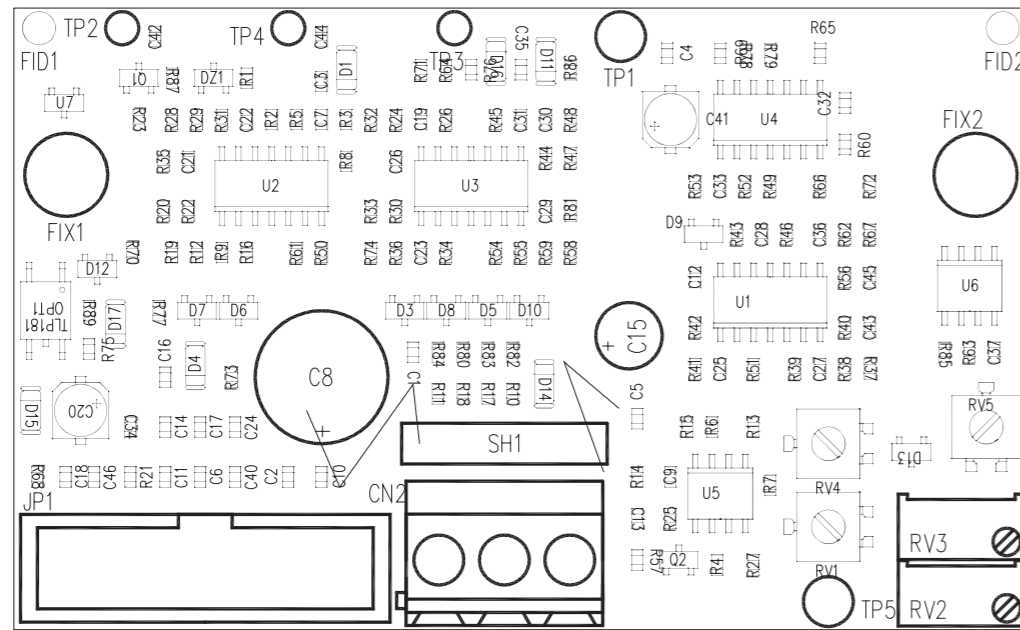

Controllo finale MOS 300W Revised: Friday, July 21, 2006
SL045DR1101 Revision: 1.0
Controllo finale MOS per PJ 300C-LCD 2U
123
Luca Gasperini

Item	Quantity	Reference	Part	{description}
1	1	CN2	CN03KRA	MORSKRA3
2	3	C1, C4, C5	4n7	Cond. SMD 0805 100V CCC085472KDX
3	16	C2, C6, C7, C11, C14, C16, C17, C18, C19, C23, C24, C27, C40, C42, C44, C45	1 nF	Cond. SMD 0805 CCC085102JNC
4	2	C34, C3	1 uF	Cond. SMD 0805 CCC085105KYC
5	1	C8	220uF 63V	Cond. Elett. Dia 10 P5.08 CEA227MB630V
6	1	C9	100pF	Cond. SMD 0805 CCC085101JCC
7	7	C12, C21, C26, C32, C35, C37, C46	100 nF	Cond. SMD 0805 CCC085104KXC
8	6	C13, C25, C28, C29, C30, C43, C10	NC	Cond. SMD 0805
9	1	C15	NC	Cond. Elett. Dia 5 P2.54
10	2	C20, C41	10 uF 35 V	Cond. Elett. SMD d. 4mm CES106B350
11	4	C22, C31, C33, C36	470 nF	Cond. SMD 0805 CCC085474KXB
12	1	DZ1	LM4040-10 V	Diode Zener SMD SOT23 CILLM4040-10
13	2	D1, D14	10 V	MINIMELF SMD Zener Diode DIZ10VMINI
14	5	D3, D5, D8, D9, D10	HSMS2800	Diodo Schottky SOT23 DISHSMS2800
15	2	D4, D17	5V1	MINIMELF SMD Zener Diode DIZ5V1MINI
16	3	D6, D7, D13	BAV 70	Doppio Diodo SMD SOT23 DISBAV70
17	1	D11	NC	MINIMELF SMD Zener Diode
18	1	D12	HSMS2804	Doppio Diodo SMD SOT23 DISHSMS2804
19	1	D15	15 V	MINIMELF SMD Zener Diode DIZ15VMINI
20	1	D16	NC	
21	2	FIX1, FIX2	FIX35	Foro fissaggio 3.5mm
22	1	JP1	CN16PD	Connettore 16 poli Flat cs CNTMCS16A
23	1	OPT1	OPTOSM1	LEDTL181
24	1	Q1	NC	Trans. NPN SOT23
25	1	Q2	MMBT540LT1	Trans. PNP SOT23 TRNMMBT5401
26	3	RV1, RV4, RV5	5 K	Trimmer SMD RVT4X4K0005V
27	1	RV2	20 K REG O.	Trimmer Rg V 3296W RVT3296WK020
28	1	RV3	20 K REG O.	Trimmer Rg V 3296W RVT3296WK020
29	5	R1, R30, R33, R39, R67	470 R	Res. SMD 0805 RCH085F0470H
30	8	R2, R4, R8, R32, R35, R43, R56, R74	51 R	Res. SMD 0805 RCH085F0051H
31	5	R3, R24, R51, R53, R59	20 K	Res. SMD 0805 RCH085F0020K
32	1	R5	9K31	Res. SMD 0805 RCH085F09K31
33	16	R6, R7, R15, R19, R21, R34, R36, R46, R47, R52, R58, R63, R80, R82, R83, R84	10 K	Res. SMD 0805 RCH085F0010K
34	12	R9, R22, R23, R44, R45, R64, R68, R70, R73, NC, R79, R85, R86		Res. SMD 0805
35	4	R10, R11, R17, R18	820 R	Res. SMD 0805 RCH085F0825H
36	12	R12, R16, R20, R26, R28, R38, R54, R55, R61, R66, R75, R81	1 K	Res. SMD 0805 RCH085F0001K
37	2	R13, R14	47 K	Res. SMD 0805 RCH085F0047K
38	4	R25, R37, R49, R50	100 R	Res. SMD 0805 RCH085F0100H
39	2	R27, R42	4K7	Res. SMD 0805 RCH085F004K7
40	1	R29	18 K	Res. SMD 0805 RCH085F0018K
41	1	R31	11K5	Res. SMD 0805 RCH085F011K5
42	1	R40	82 K	Res. SMD 0805 RCH085F0082K
43	1	R41	165 K	Res. SMD 0805 RCH085F0165K
44	2	R48, R62	28 K	Res. SMD 0805 RCH085F0028K
45	1	R57	82 R	Res. SMD 0805 RCH085F0082H
46	4	R60, R65, R69, R89	220 R	Res. SMD 0805 RCH085F0220H
47	4	R71, R76, R78, R87	0 R	Res. SMD 0805 RCH085F0000H
48	1	R72	3K9	Res. SMD 0805 RCH085F003K9
49	1	R77	1 M	Res. SMD 0805 RCH085F0001M
50	1	SH1	SHUNT	Shunt passo 15.2mm fori 2mm RSH10A0H01
51	1	TP1	VPA	Foro dia. 2mm
52	1	TP2	FWD	Foro dia. 1mm
53	1	TP3	CONT.	Foro dia. 1mm
54	1	TP4	RFD	Foro dia. 1mm
55	1	TP5	GND	Foro dia. 2mm
56	2	U1, U2	LM324SMD	Quad Op. SMD SO14 CILLM324SMD
57	2	U4, U3	TL074SMD	Quad Op. SMD SO14 CILTL074SMD
58	1	U5	TL071/SO	Dual Op. SMD SO8 CILTL071SMD
59	1	U6	LM358	Dual Op. SMD SO8 CILLM358SMD
60	1	U7	LM50C_SMD	Temperature sensor CILLM50C
61	1	CS1		Circuito stampato CSCNTMOS03

A.V.R. ELETTRONICA	NOME PROGETTO: CONTROLLO FINALE MOS	NOME PARTE: SCHEDA CONTROLLO FINALE MOS
	AUTORE: L. GASPERINI	DATA: 13/04/2005 REVISIONE: 1.0 SCALA: 2:1 SIZE: A4 PAGINA: 1 DI 1
ARCHIVIAZIONE ELETTRONICA: "CARTELLA PROGETTI" SU "UT_SRV"	CODICE PROGETTO: 030	CODICE DISEGNO: CSCNTMOS03
MATERIALE: <>	TRATTAMENTO: <>	PROFILO: <>
		STATO: PROGETTUALE

PAD DESCRIPTION
 PAD1: INPUT RF
 PAD2: INPUT +18 Vcc FROM BIAS CONTROL CARD
 PAD3: INPUT BIAS VOLTAGE FROM BIAS CONTROL CARD
 PAD4: INPUT +50 Vcc FROM BIAS CONTROL CARD
 PAD5: PAD FOR CIRCUIT FUNCTIONALLY
 PAD6: OUTPUT FWD VOLTAGE FROM DRCP
 PAD7: OUTPUT RFD VOLTAGE FROM DRCP
 PAD8: OUTPUT POWER
 PAD9: OUTPUT RF TEST
 PAD10: ADJUST C4 FOR MINIMUM VOLTAGE ON THIS PAD
 PAD11: PAD FOR CIRCUIT FUNCTIONALLY
 JUMPER DESCRIPTION
 J1: PAD TO ADJUST 100mA SD2942_Idq WITH RV2

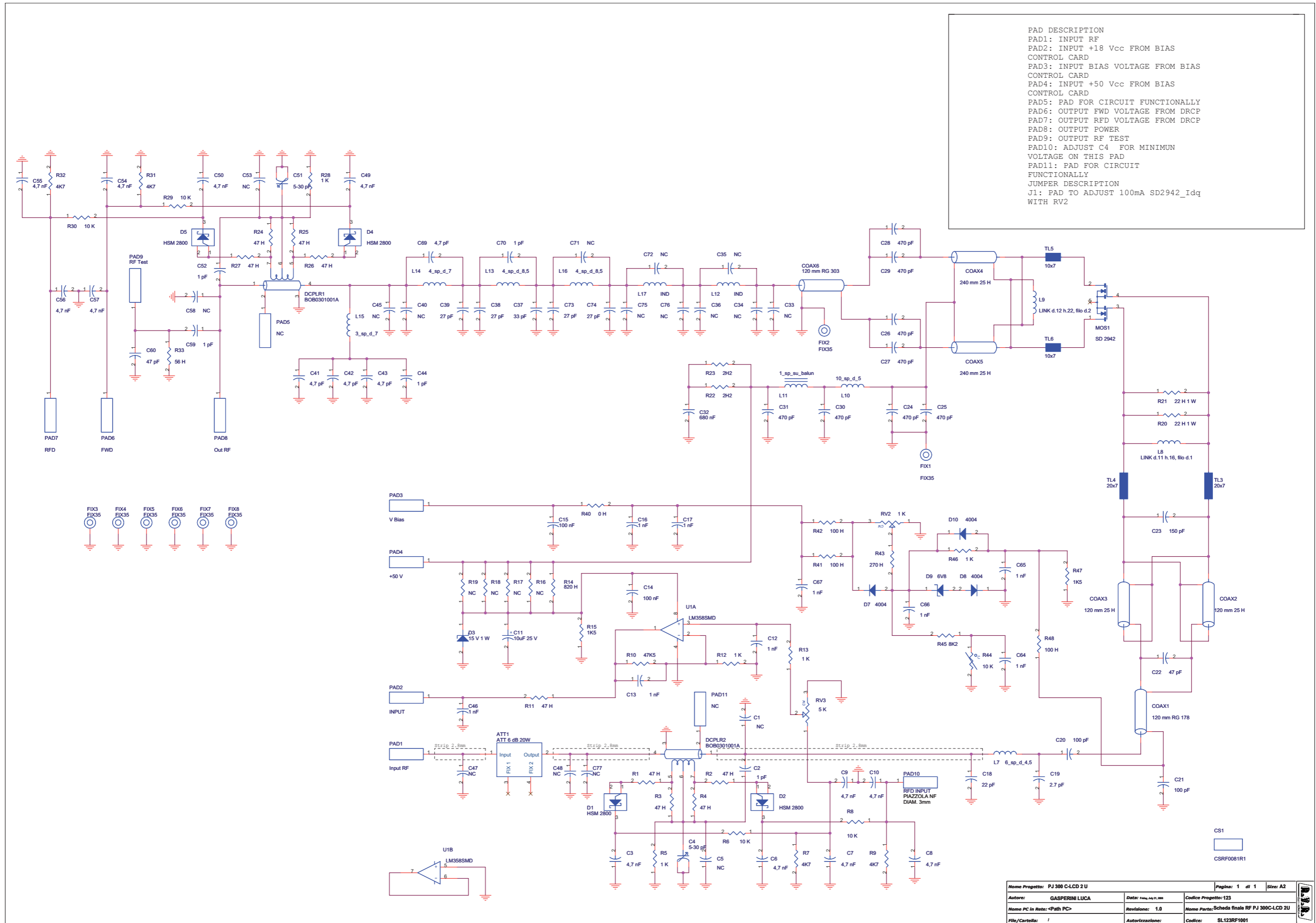

Nome Progetto: PJ 300 C-LCD 2 U	Pagina: 1 di 1	Size: A2
Autore: GASPERINI LUCA	Data: 15/12/06	Codice Progetto: 123
Nome PC in Rete: <Path PC>	Revisione: 1.0	Nome Parte: Scheda finale RF PJ 300C-LCD 2U
File/Cartella: /	Autorizzazione:	Codice: SL123RF1001

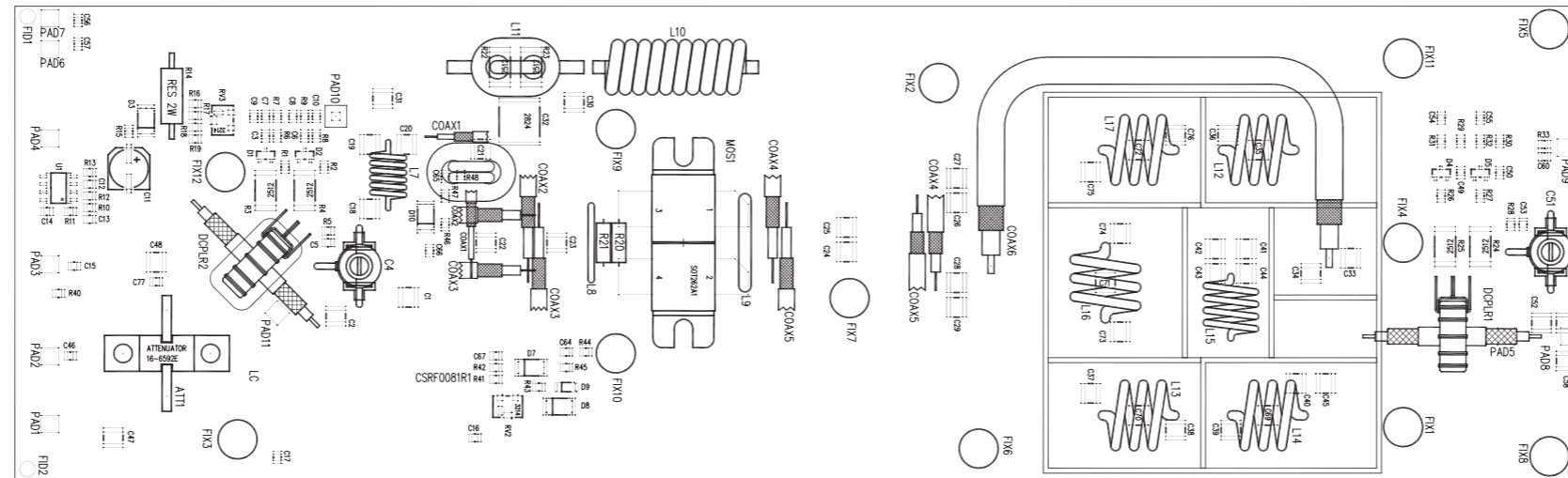

	NOME PROGETTO: PJ300C-LCD	NOME PARTE: SCHEDA FINALE RF			
	AUTORE: L. GASPERINI	DATA: 21/09/2006	REVISIONE: 1.0	SCALA: 1:1	SIZE: A3
ARCHIVIAZIONE ELETTRONICA: "CARTELLA RILASCIATI" SU "UTSRV"		CODICE PROGETTO: 123	CODICE DISEGNO: SL123RF1001		
MATERIALE: <>	TRATTAMENTO: <>	PROFILO: <>	STATO: ESECUTIVO		

Scheda finale RF PJ 300C-LCD 2U Revised: Friday, July 21, 2006

SL123RF1001 Revision: 1.0

PJ 300 C-LCD 2 U

123

GASPERINI LUCA

Item	Quantity	Reference	Part	(description)
1	1	ATT1	ATT 6 dB 20W	RAT06DB050W
2	1	COAX1	120 mm RG 178	Cavo coax CAVRG178
3	2	COAX3, COAX2	120 mm 25 H	Cavo coax CAVRG316/25
4	2	COAX4, COAX5	240 mm 25 H	Cavo coax CAVRG316/25
5	1	COAX6	120 mm RG 303	Cavo coax CAVRG3003
6	1	CS1	CSRF0081R1	Circuito stampato CSRF0081R1
7	14	C1, C33, C34, C35, C36, C40, C45, C47, C48, C58, C71, C72, C75, C76	NC	Cond. SMD 1212 HQ
8	5	C2, C44, C52, C59, C70	1 pF	Cond. SMD 1212 HQ CHQ010CA501
9	12	C3, C6, C7, C8, C9, C10, C49, C50, C54, C55, C56, C57	4,7 nF	Cond. SMD 0805 CCC085472KXC
10	2	C4, C51	5-30 pF	Comp. ceramico dia. 7mm CVC300D07
11	3	C5, C53, C77	NC	Cond. SMD 0805
12	1	C11	10uF 25 V	Cond. Elett. SMD d. 6.3mm CES106B350
13	9	C12, C13, C16, C17, C46, C64, C65, C66, C67	1 nF	Cond. SMD 0805 CCC085102JNC
14	2	C14, C15	100 nF	Cond. SMD 0805 CCC085104KXC
15	1	C18	22 pF	Cond. SMD 1212 HQ CHQ220JA501
16	1	C19	2.7 pF	Comp. Ceramico p.5mm CKM2,7KC600C
17	2	C21, C20	100 pF	Cond. SMD 1212 HQ CHQ101JA501
18	1	C22	47 pF	Cond. SMD 1212 HQ CHQ470JA501
19	1	C23	150 pF	Cond. SMD 1212 HQ CHQ151JA301
20	8	C24, C25, C26, C27, C28, C29, C30, C31	470 pF	Cond. SMD 1212 HQ CHQ471JA201
21	1	C32	680 nF	Cond. SMD 2824 CPE684K1010
22	1	C37	33 pF	Cond. SMD 1212 HQ CHQ330JA501
23	4	C38, C39, C73, C74	27 pF	Cond. SMD 1212 HQ CHQ270JA501
24	4	C41, C42, C43, C69	4,7 pF	Cond. SMD 1212 HQ CHQ4P7CA501
25	1	C60	47 pF	Cond. SMD 0805 CCC085470JCC
26	2	DCPLR1, DCPLR2	BOB0301001A	Accopp. direz. BOB0301001A
27	4	D1, D2, D4, D5	HSM 2800	DISHSMS2800
28	1	D3	15 V	MELF SMD Zener Diode DIZ15VMELF
29	3	D7, D8, D10	4004	MELF SMD Diode DIS4004MELF
30	1	D9	6V8	MINIMELF SMD Zener Diode DIZ6V8MINI
31	8	FIX1, FIX2, FIX3, FIX4, FIX5, FIX6, FIX7, FIX8	FIX35	Foro fissaggio 3.5mm
32	1	L7	6_sp_d_4,5	Induttanza cilindrica BOB01010006A
33	1	L8	LINK d.11 h.16, filo d.1	Induttanza cilindrica BOB01020079A
34	1	L9	LINK d.12 h.22, filo d.2	Induttanza cilindrica BOB01020076A
35	1	L10	10_sp_d_5	Induttanza cilindrica BOB01010005A
36	1	L11	1_sp_su_balun	BOB02020001A
37	2	L17, L12	NC	Induttanza cilindrica
38	2	L13, L16	4_sp_d_8,5	Induttanza cilindrica BOB01020082A
39	1	L14	4_sp_d_7	Induttanza cilindrica BOB01020001A
40	1	L15	3_sp_d_7	Induttanza cilindrica BOB01020083A
41	1	MOS1	SD 2942	PP Power mosfet RF TRNSD2942
42	1	PAD1	Input RF	
43	1	PAD2	INPUT	
44	1	PAD3	V Bias	
45	1	PAD4	+50 V	
46	2	PAD11, PAD5	NC	
47	1	PAD6	FWD	
48	1	PAD7	RFD	
49	1	PAD8	Out RF	
50	1	PAD9	RF Test	
51	1	PAD10	RFD INPUT	
52	1	RV2	1 K	Trimmer SMD RVTMLK0001VS
53	1	RV3	5 K	Trimmer SMD RVTMLK0005VS
54	5	R1, R2, R11, R26, R27	47 H	Res. SMD 0805 1% RCH085F0047H
55	4	R3, R4, R24, R25	47 H	Res. SMD 2512 1% RCH252J0047H
56	5	R5, R12, R13, R28, R46	1 K	Res. SMD 0805 1% RCH085F0001K
57	4	R6, R8, R29, R30	10 K	Res. SMD 0805 1% RCH085F0010K
58	4	R7, R9, R31, R32	4K7	Res. SMD 0805 1% RCH085F04K75
59	1	R10	47K5	Res. SMD 0805 1% RCH085F047K5
60	1	R14	820 H	Res. 2W RSM002J0820H
61	2	R15, R47	1K5	Res. SMD 0805 1% RCH085F001K5
62	4	R16, R17, R18, R19	NC	Res. SMD 0805 1%
63	2	R20, R21	22 H 1 W	Res. 1/4W 1% RSM001J0022H
64	2	R22, R23	2H2	Res. SMD 2512 1% RCH252J002H2
65	1	R33	56 H	Res. SMD 0805 1% RCH085F0056H

Item	Quantity	Reference	Part	(description)
66	1	R40	0 H	Res. SMD 0805 1% RCH085F0000H
67	3	R41, R42, R48	100 H	Res. SMD 0805 1% RCH085F0100H
68	1	R43	270 H	Res. SMD 0805 1% RCH085F0270H
69	1	R44	10 K	Res. SMD 0805 NTC RNTC085K103K
70	1	R45	8K2	Res. SMD 0805 1% RCH085F008K2
71	2	TL3, TL4	20x7	Linea strip CS
72	2	TL5, TL6	10x7	Linea strip CS
73	1	U1	LM358SMD	Dual Op. SMD SO8 CILLM358SMD

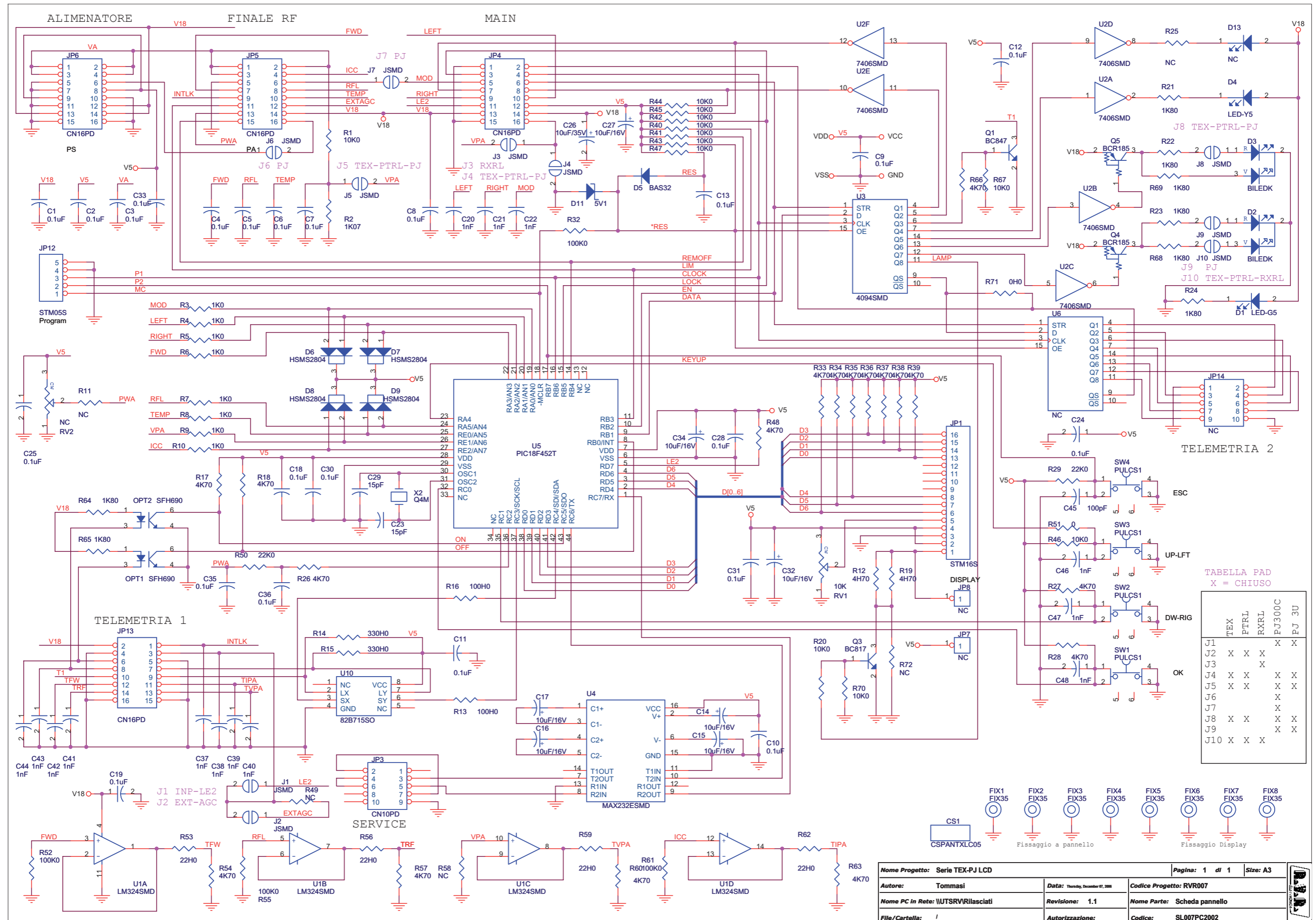

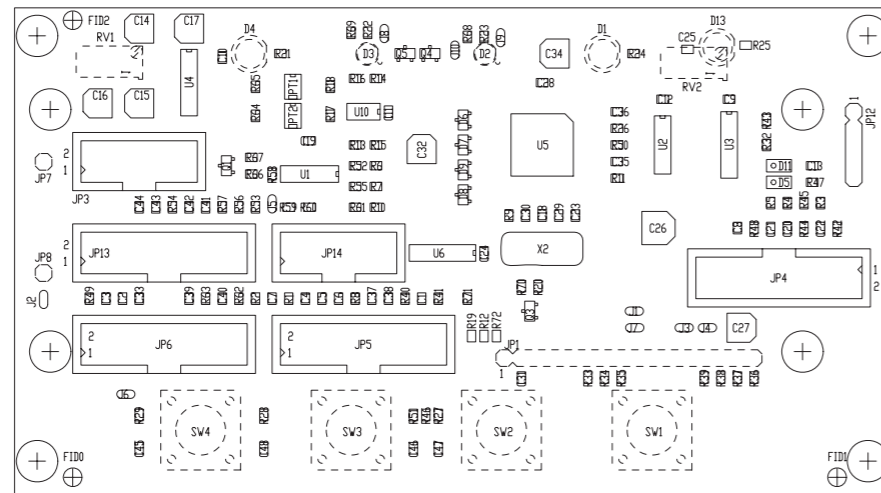

Scheda pannello serie TEX/PJ - SL007PC2002
30/10/2006 Revision: 1.1
Serie TEX-PJ LCD
RVR007
Tommasi

Item	Quantity	Reference	Part	Description	Code
1	1	CS1	CSPANTXLC05	Circuito stampato	CSPANTXLC05
2	23	C1,C2,C3,C4,C5,C6,C7,C8,C9,C10,C11,C12,C13,C18,C19,C24,C25,C28,C30,C31,C33,C35,C36	0.1uF	Cond. SMD 0805	CCC085104KXC
3	7	C14,C15,C16,C17,C27,C32,C34	10uF/16V	Cond. Elett. SMD d. 4mm	CES106A160
4	14	C20,C21,C22,C37,C38,C39,C40,C41,C42,C43,C44,C46,C47,C48	1nF	Cond. SMD 0805	CCC085102KXC
5	2	C23,C29	15pF	Cond. SMD 0805	CCC085150JCC
6	1	C26	10uF/35V	Cond. Elett. SMD d. 5mm	CES106B350
7	1	C45	100pF	Cond. SMD 0805	CCC085101JCC
8	1	D1	LED-G5	LED Verde dia. 5mm	LEDV05
9	2	D2,D3	BILEDK	Doppio led V-R 5mm Catodo com.	LEDB05
10	1	D4	LED-Y5	LED Giallo dia. 5mm	LEDG05
11	1	D5	BAS32	MINIMELF SMD Diode	DISBAS32MINI
12	4	D6,D7,D8,D9	HSMS2804	Doppio Diodo SMD SOT23	DISHSMS2804
13	1	D11	5V1	MINIMELF SMD Zener Diode	DIZ5V1MINI
14	1	D13	NC	LED Giallo dia. 5mm	
15	8	FIX1, FIX2, FIX3, FIX4, FIX5, FIX6, FIX7, FIX8	FIX35	Foro fissaggio 3.5mm	
16	1	JP1	STM16S	Strip maschio 16 pin	Stecca tagliata
17	1	JP3	CN10PD	Connettore 10 poli Flat cs	CNTMCS10A
18	4	JP4, JP5, JP6, JP13	CN16PD	Connettore 16 poli Flat cs	CNTMCS16A
19	3	JP7, JP8, JP14	NC		
20	1	JP12	STM05S	Strip maschio 5 pin	Stecca tagliata
21	10	J1, J2, J3, J4, J5, J6, J7, J8, J9, J10	JSM D	Pad SMD a saldare	
22	2	OPT1, OPT2	SFH690	Optoisolatore SMD SO6	LEDTLP181
23	1	Q1	BC847	Trans. NPN SOT23	TRNBC847
24	1	Q3	BC817	Trans. NPN SOT23	TRNBC817
25	2	Q4, Q5	BCR185	Trans./Res. PNP SOT23	TRNBCR185
26	1	RV1	10K	Trimmer Rg V 3296W	RVT3296WK010
27	1	RV2	NC	Trimmer Rg V 3296W	
28	12	R1, R20, R40, R41, R42, R43, R44, R45, R46, R47, R67, R70	10K0	Res. SMD 0805 1%	RCH085F0010K
29	1	R2	1K07	Res. SMD 0805 1%	RCH085F01K07
30	8	R3, R4, R5, R6, R7, R8, R9, R10	1K0	Res. SMD 0805 1%	RCH085F0001K
31	5	R11, R25, R49, R58, R72	NC	Res. SMD 0805 1%	
32	2	R12, R19	4H70	Res. SMD 0805 1%	RCH085F004H7
33	2	R13, R16	100H0	Res. SMD 0805 1%	RCH085F0100H
34	2	R14, R15	330H0	Res. SMD 0805 1%	RCH085F0330H
35	18	R17, R18, R26, R27, R28, R33, R34, R35, R36, R37, R38, R39, R48, R54, R57, R60, R63, R66	4K70	Res. SMD 0805 1%	RCH085F004K7
36	8	R21, R22, R23, R24, R64, R65, R68, R69	1K80	Res. SMD 0805 1%	RCH085F001K8
37	2	R29, R50	22K0	Res. SMD 0805 1%	RCH085F0022K
38	4	R32, R52, R55, R61	100K0	Res. SMD 0805 1%	RCH085F0100K
39	2	R51, R71	0H0	Res. SMD 0805 1%	RCH085F0000H
40	4	R53, R56, R59, R62	22H0	Res. SMD 0805 1%	RCH085F0022H
41	4	SW1, SW2, SW3, SW4	PULCS1	Pulsante cs	PLC1V1M000M
42	1	U1	LM324SMD	Quad Op. SMD SO14	CILLM324SMD
43	1	U2	7406SMD	Hex inv OC SMD SO14	CID7406SMD
44	1	U3	4094SMD	Shift Reg. SMD SO16	CIDCD4094SMD
45	1	U4	MAX232ESMD	RS232 Driver SMD SO16	CIDMX232CSES
46	1	U5	PIC18F452T	TQFP44 SMD Microprocessor	CIDPIC18F452
47	1	U10	82B715SO	IIC Bus driver SMD SO8	CID82B715S
48	1	X2	Q4M	Quarzo SMD HC49SMD	QRZ000004MC
49	1	U6	NC	Shift Reg. SMD SO16	

R.V.R. ELETTRONICA	NOME PROGETTO: TEX-LCD PIC-LCD PTRL RXRL	NOME PARTE: SCHEDA PANNELLO			
	AUTORE: A. TOMMASI	DATA: 12/09/2006	REVISIONE: 1.0	SCALA: 1:1	SIZE: A4
ARCHIVIAZIONE ELETTRONICA: "CARTELLA RILASCIATI" SU "UTSRV"		CODICE PROGETTO: 007 - 010	CODICE DISEGNO: SL007PC2002		
MATERIALE: <>	TRATTAMENTO: <>	PROFILO: <>	STATO: ESECUTIVO		

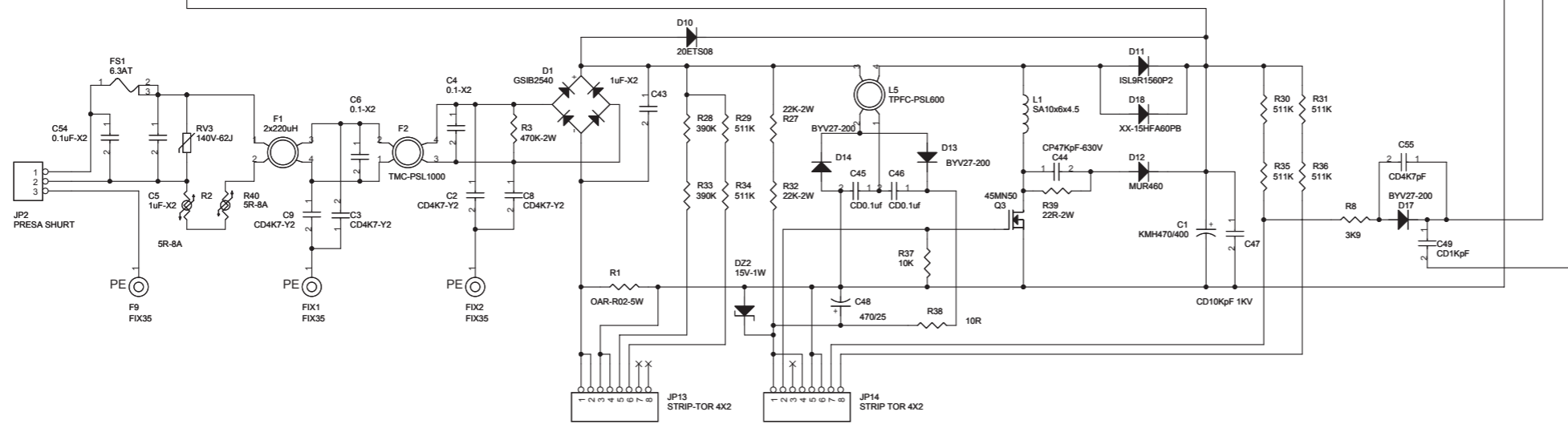
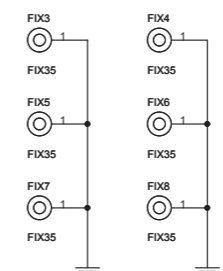
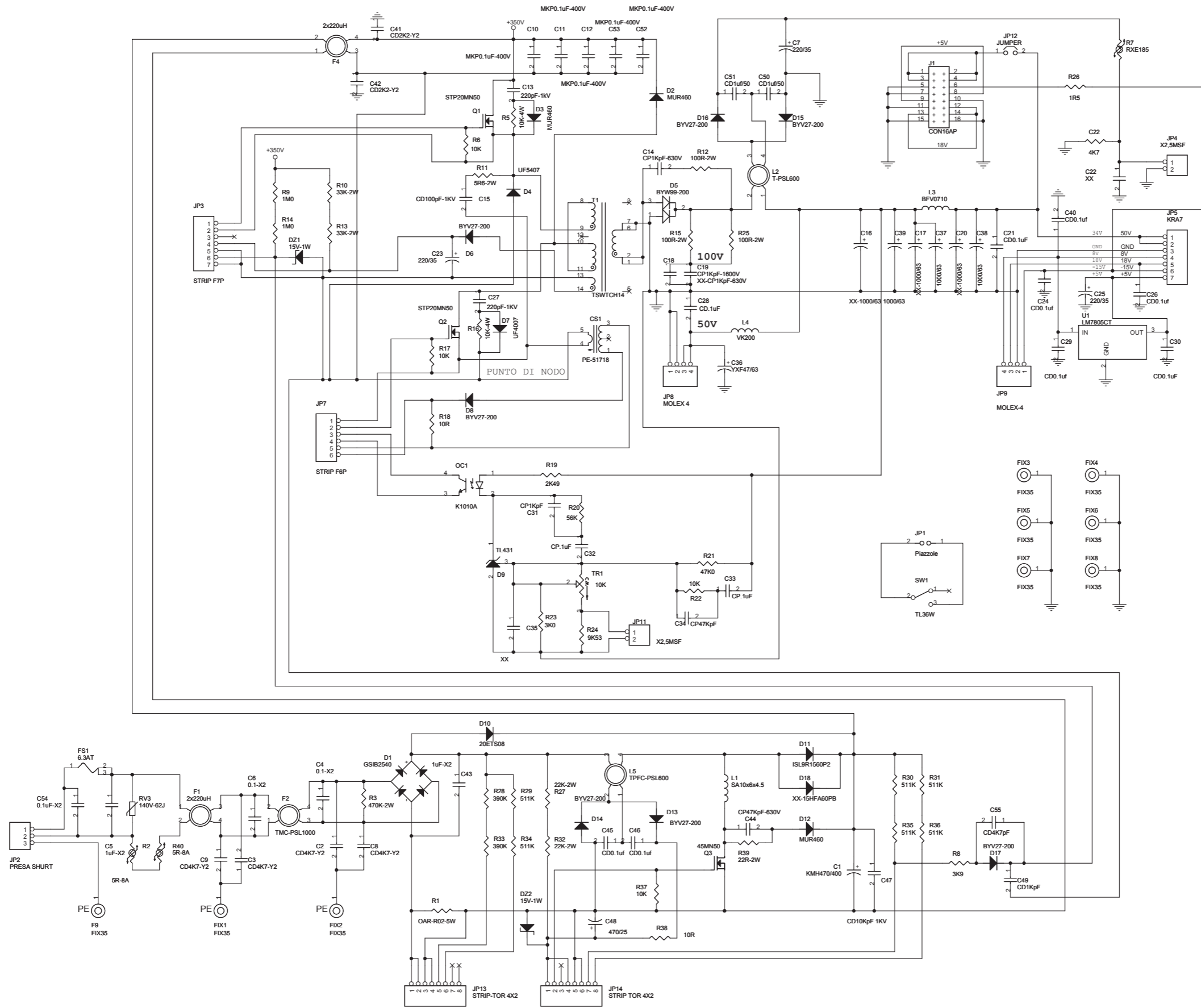

Nome Progetto:	TEX300-LCD	Revisione:	1.0	Scale:	A3
Autore:	GP - REV.: J.BERTI	Data:	04/05/2006	Codice Progetto:	045
Nome PC in Rete:	WUTSRV	Revisione:	1.0	Nome Parte:	POWER PSL 300
File/Cartella:	PSL600_PWR_R2.DSN	Autorizzazione:		Codice:	PSL300

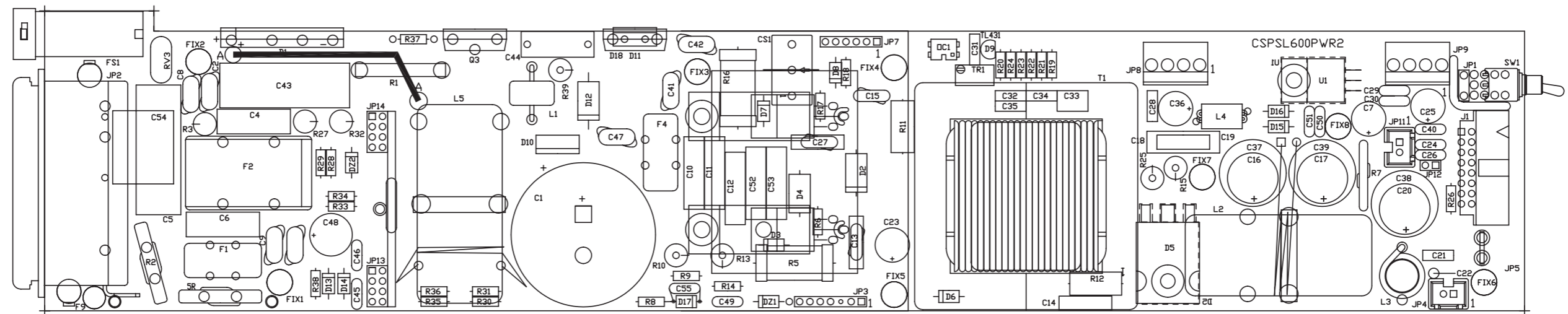

	NOME PROGETTO: TEX300-LCD	NOME PARTE: Main Card			
	AUTORE: U.T. - rev.: J. Berti	DATA: 05/04/2006	REVISIONE: 1.0	SCALA: 1:1	SIZE: A3
ARCHIVIAZIONE ELETTRONICA: "CARTELLA PROGETTI" SU "UT_SRV"		CODICE PROGETTO: 045	CODICE DISEGNO: PSL600		
MATERIALE: /	TRATTAMENTO: /	PROFILO: /	STATO: /		

Revised: Thursday, October 12, 2006
Revision:

Item	Quantity	Reference	Part
1	1	CS1	PE-51718
2	1	C1	KMH470/400
3	4	C2, C3, C8, C9	CD4K7-Y2
4	2	C4, C6	0.1-X2
5	2	C5, C43	1uF-X2
6	3	C7, C23, C25	220/35
7	5	C10, C11, C12, C52, C53	MKP0.1uF-400V
8	2	C13, C27	220pF-1KV
9	1	C14	CP1KpF-630V
10	1	C15	CD100pF-1KV
11	3	C16, C17, C20	XX-1000/63
12	1	C18	XX-CP1KpF-630V
13	1	C19	CP1KpF-1600V
14	8	C21, C24, C26, C29, C30, C40, C45, C46	CD0.1uF
15	1	C22	4K7
16	2	C22, C35	XX
17	1	C28	CD.1uF
18	1	C31	CP1KpF
19	2	C32, C33	CP.1uF
20	1	C34	CP47KpF
21	1	C36	YXF47/63
22	3	C37, C38, C39	1000/63
23	2	C41, C42	CD2K2-Y2
24	1	C44	CP47KpF-630V
25	1	C47	CD10KpF 1KV
26	1	C48	470/25
27	1	C49	CD1KpF
28	2	C50, C51	CD1uF/50
29	1	C54	0.1uF-X2
30	1	C55	CD4K7pF
31	2	DZ1, DZ2	15V-1W
32	1	D1	GSIB2540
33	3	D2, D3, D12	MUR460
34	1	D4	UF5407
35	1	D5	BYW99-200
36	7	D6, D8, D13, D14, D15, D16, D17	BYV27-200
37	1	D7	UF4007
38	1	D9	TL431
39	1	D10	20ETS08
40	1	D11	ISL9R1560P2
41	1	D18	XX-15HFA60PB
42	9	FIX1, FIX2, FIX3, FIX4, FIX5, FIX6, FIX7, FIX8, F9	FIX35
43	1	FS1	6.3AT
44	2	F1, F4	2x220uH
45	1	F2	TMC-PSL1000
46	1	JP1	Piazzole
47	1	JP2	PRESA SHURT
48	1	JP3	STRIP F7P
49	2	JP4, JP11	X2,5MSF
50	1	JP5	KRA7
51	1	JP7	STRIP F6P
52	1	JP8	MOLEX 4
53	1	JP9	MOLEX-4
54	1	JP12	JUMPER
55	1	JP13	STRIP-TOR 4X2
56	1	JP14	STRIP TOR 4X2
57	1	J1	CON16AP
58	1	L1	SA10x6x4.5
59	1	L2	T-PSL600
60	1	L3	BFV0710
61	1	L4	VK200

Item	Quantity	Reference	Part
62	1	L5	TPFC-PSL600
63	1	OC1	K1010A
64	2	Q1, Q2	STP20MN50
65	1	Q3	45MN50
66	1	RV3	140V-62J
67	1	R1	OAR-R02-5W
68	2	R2, R40	5R-8A
69	1	R3	470K-2W
70	2	R5, R16	10K-4W
71	5	TR1, R6, R17, R22, R37	10K
72	1	R7	RXE185
73	1	R8	3K9
74	2	R9, R14	1M0
75	2	R10, R13	33K-2W
76	1	R11	5R6-2W
77	3	R12, R15, R25	100R-2W
78	2	R18, R38	10R
79	1	R19	2K49
80	1	R20	56K
81	1	R21	47K0
82	1	R23	3K0
83	1	R24	9K53
84	1	R26	1R5
85	2	R27, R32	22K-2W
86	2	R28, R33	390K
87	6	R29, R30, R31, R34, R35, R36	511K
88	1	R39	22R-2W
89	1	SW1	TL36W
90	1	T1	TSWTCH14
91	1	U1	LM7805CT

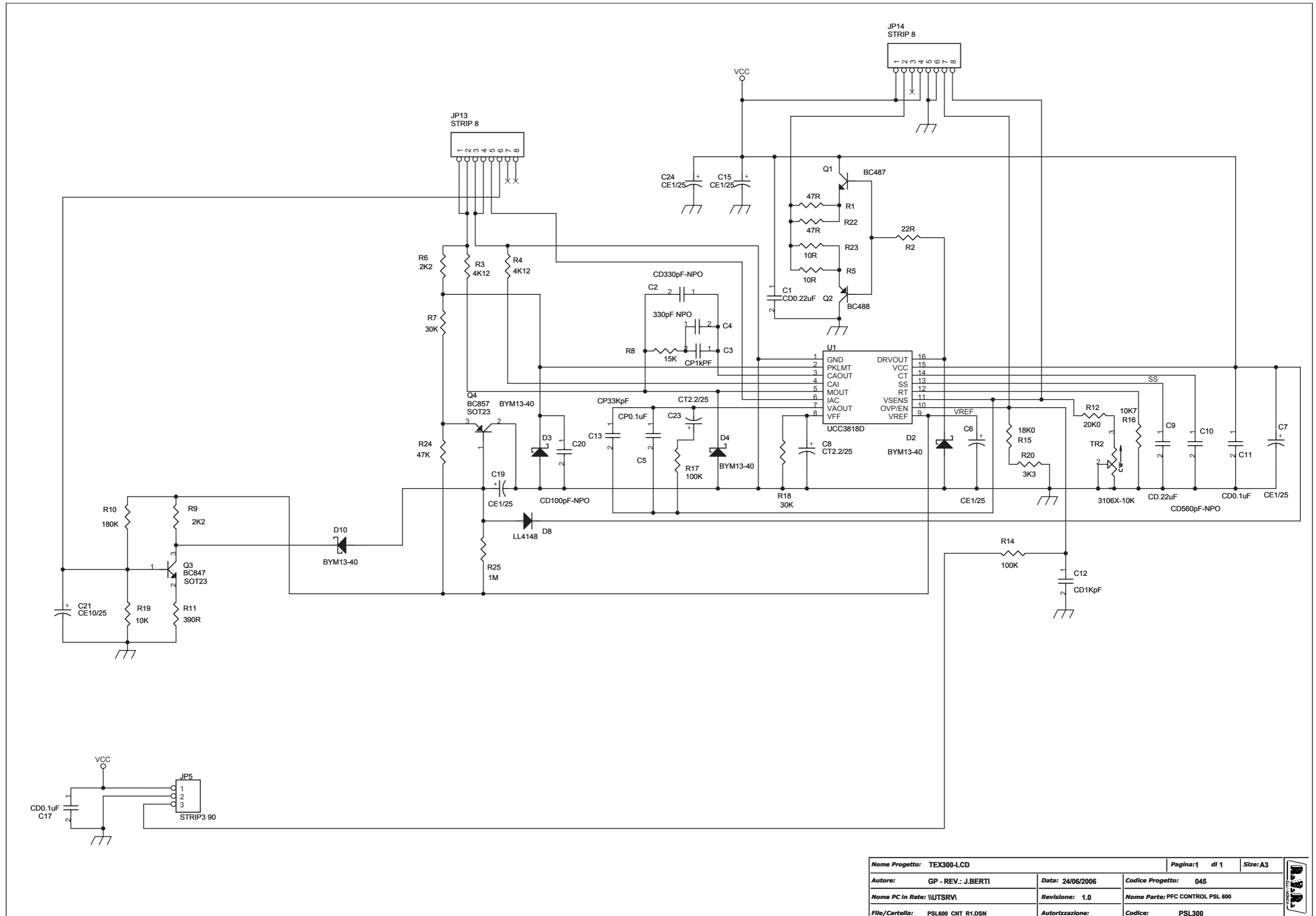

Nome Progetto: TEX300-LCD		Pagina: 1 di 1	Size: A3
Autore: GP - REV.: J.BERTI	Data: 24/06/2006	Codice Progetto: 045	
Nome PC In Rete: \\\UTSRV\	Revisione: 1.0	Nome Parte: PFC CONTROL PSL 600	
File/Cartella: PSL600_CNT_R1.DSN	Autorizzazione:	Codice: PSL300	

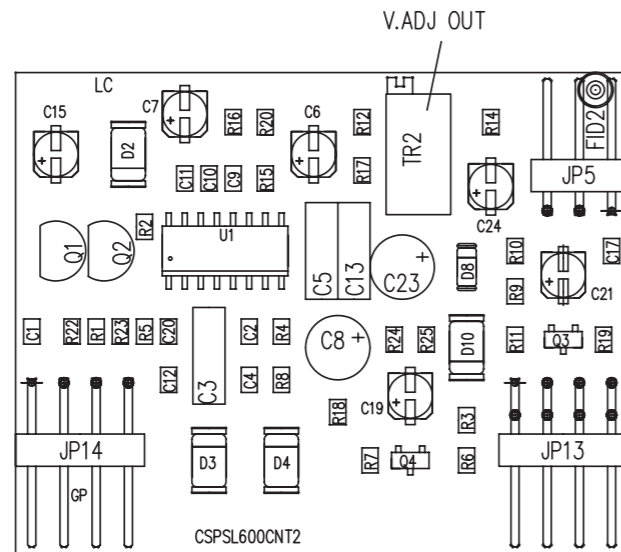

Revised: Thursday, October 12, 2006
Revision:

Item	Quantity	Reference	Part
1	1	C1	CD0.22uF
2	1	C2	CD330pF-NPO
3	1	C3	CP1kPF
4	1	C4	330pF NPO
5	1	C5	CP0.1uF
6	5	C6, C7, C15, C19, C24	CE1/25
7	2	C8, C23	CT2.2/25
8	1	C9	CD.22uF
9	1	C10	CD560pF-NPO
10	2	C11, C17	CD0.1uF
11	1	C12	CD1KpF
12	1	C13	CP33KpF
13	1	C20	CD100pF-NPO
14	1	C21	CE10/25
15	4	D2, D3, D4, D10	BYM13-40
16	1	D8	LL4148
17	1	JP5	STRIP3 90
18	2	JP13, JP14	STRIP 8
19	1	Q1	BC487
20	1	Q2	BC488
21	1	Q3	BC847
22	1	Q4	BC857
23	2	R1, R22	47R
24	1	R2	22R
25	2	R3, R4	4K12
26	2	R5, R23	10R
27	2	R6, R9	2K2
28	2	R7, R18	30K
29	1	R8	15K
30	1	R10	180K
31	1	R11	390R
32	1	R12	20K0
33	2	R14, R17	100K
34	1	R15	18K0
35	1	R16	10K7
36	1	R19	10K
37	1	R20	3K3
38	1	R24	47K
39	1	R25	1M
40	1	TR2	3106X-10K
41	1	U1	UCC3818D

R.V.R. ELETTRONICA	NOME PROGETTO: TEX300LCD	NOME PARTE: Control Card
	AUTORE: U.T. - rev.: J. Berti	DATA: 23/03/2006
ARCHIVIAZIONE ELETTRONICA: "CARTELLA PROGETTI" SU "UT_SRV"	CODICE PROGETTO: 045	REVISIONE: 1.0
MATERIALE: /	TRATTAMENTO: /	SCALA: 2:1
		SIZE: A4
		PAGINA: 1 DI 1
		CODICE DISEGNO: PSL600
		STATO: /

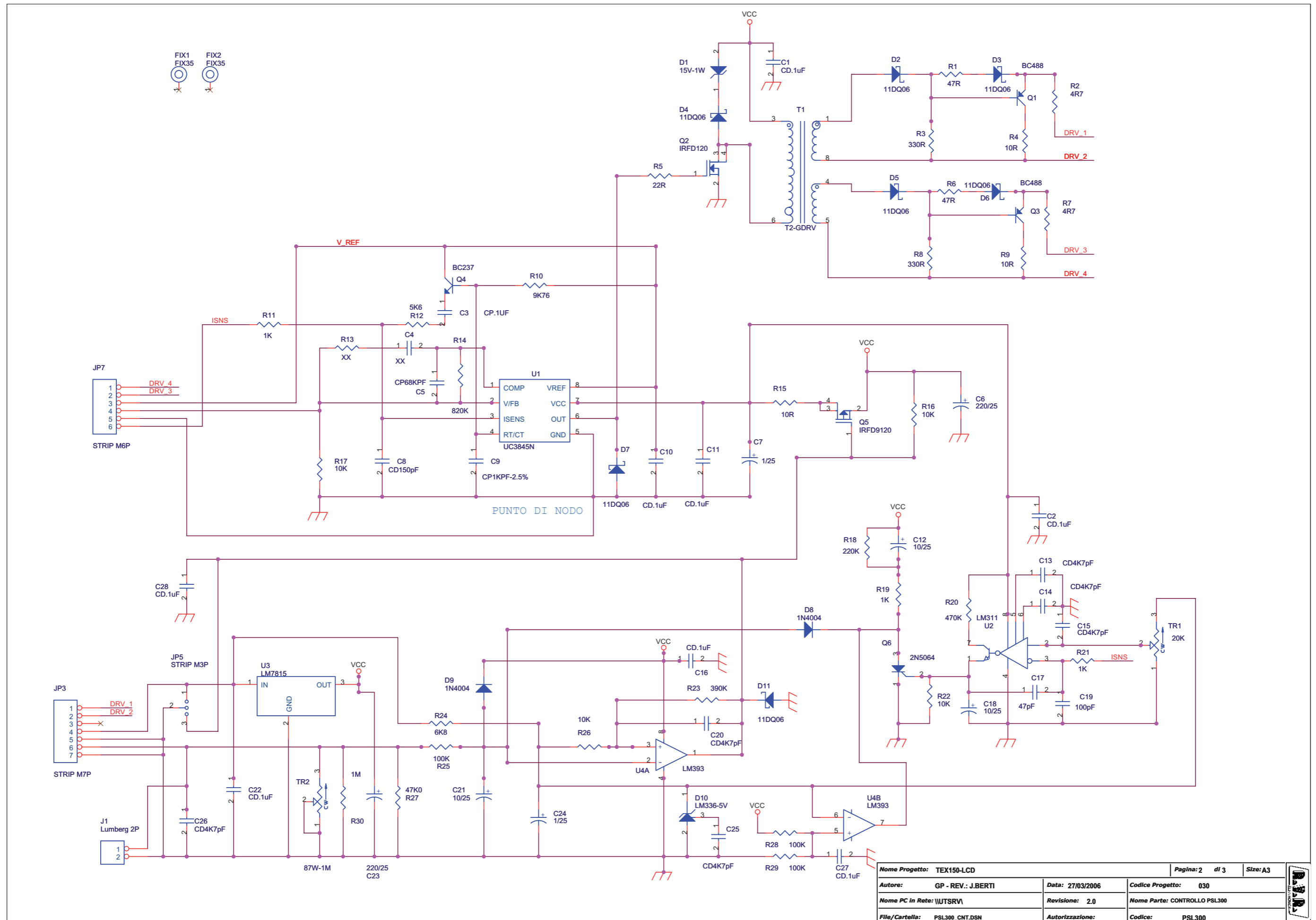

Nome Progetto: TEX150-LCD		Pagina: 2 di 3	Size: A3
Autore: GP - REV.: J.BERTI	Data: 27/03/2006	Codice Progetto: 030	
Nome PC in Rete: \UTSRV\	Revisione: 2.0	Nome Parte: CONTROLLO PSL300	
File/ Cartella: PSL300_CNT.DSN	Autorizzazione:	Codice: PSL300	

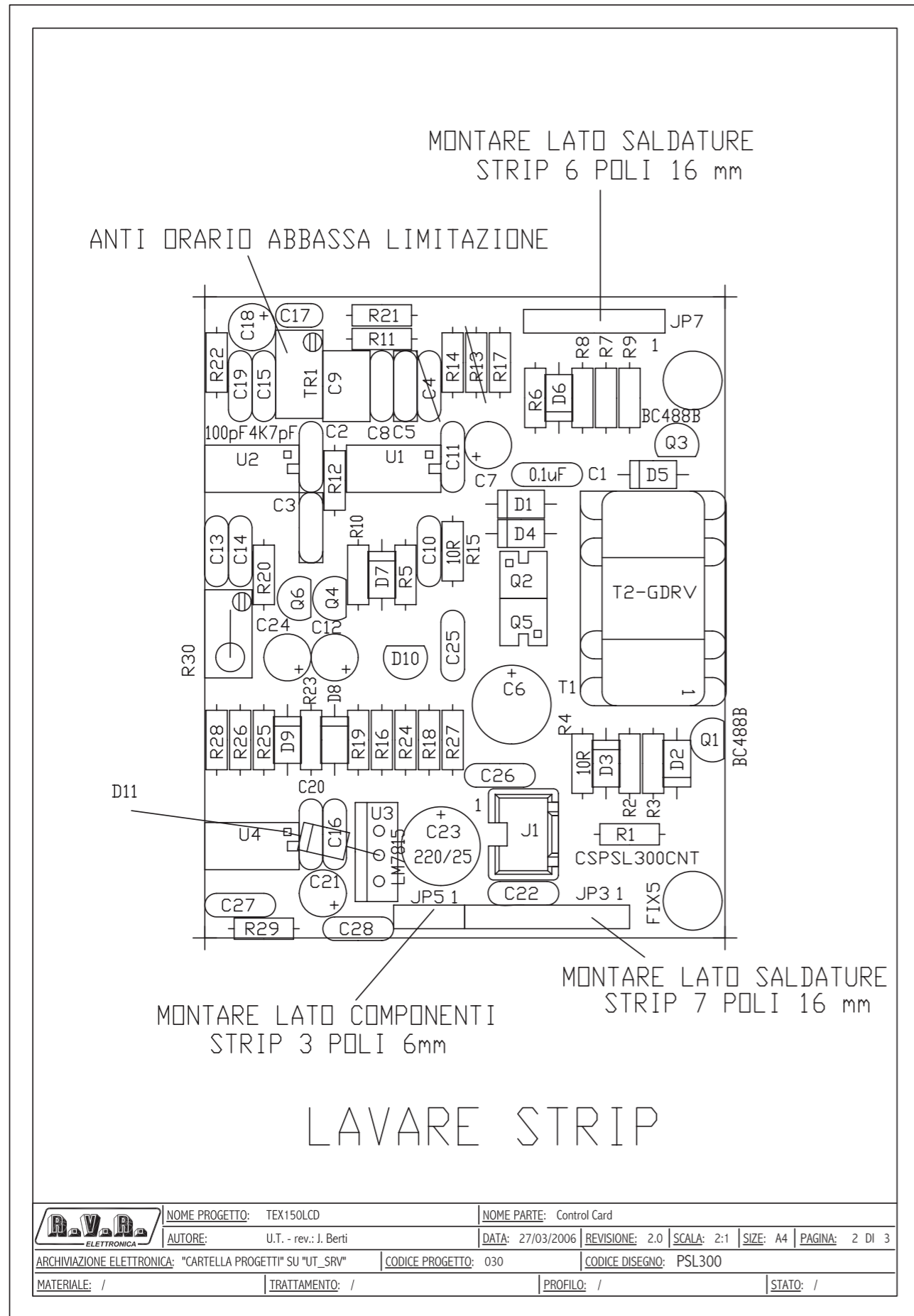

PSL300
 POWER SUPPLY +18V1.5A 8V1A 15V 0.2A
 Revised: 27/03/2006
 Revision: 2.0

Item	Quantity	Reference	Part
1	8	C1C2C10C11C16C22C27C28	CD.1uF
2	1	C3	CP.1UF
3	2	C4R13	XX
4	1	C5	CP68KPF
5	2	C6C23	220/25
6	2	C7C24	1/25
7	1	C8	CD150pF
8	1	C9	CP1KPF-2.5%
9	3	C12C18C21	10/25
10	6	C13C14C15C20C25C26	CD4K7pF
11	1	C17	47pF
12	1	C19	100pF
13	1	D1	15V-1W
14	7	D2D3D4D5D6D7D11	11DQ06
15	2	D8D9	1N4004
16	1	D10	LM336-5V
17	2	FIX1FIX2	FIX35
18	1	JP3	STRIP M7P
19	1	JP5	STRIP M3P
20	1	JP7	STRIP M6P
21	1	J1	Lumberg 2P
22	2	Q3Q1	BC488
23	1	Q2	IRFD120
24	1	Q4	BC237
25	1	Q5	IRFD9120
26	1	Q6	2N5064
27	2	R1R6	47R
28	2	R2R7	4R7
29	2	R3R8	330R
30	3	R4R9R15	10R
31	1	R5	22R
32	1	R10	9K76
33	3	R11R19R21	1K
34	1	R12	5K6
35	1	R14	820K
36	4	R16R17R22R26	10K
37	1	R18	220K
38	1	R20	470K
39	1	R23	390K
40	1	R24	6K8
41	3	R25R28R29	100K
42	1	R27	47K0
43	1	R30	1M
44	1	TR1	20K
45	1	TR2	87W-1M
46	1	T1	T2-GDRV
47	1	U1	UC3845N
48	1	U2	LM311
49	1	U3	LM7815
50	1	U4	LM393

R.V.R. ELETTRONICA	NOME PROGETTO: TEX150LCD	NOME PARTE: Control Card
	AUTORE: U.T. - rev.: J. Berti	DATA: 27/03/2006 REVISIONE: 2.0
ARCHIVIAZIONE ELETTRONICA: "CARTELLA PROGETTI" SU "UT_SRV"	CODICE PROGETTO: 030	CODICE DISEGNO: PSL300
MATERIALE: /	TRATTAMENTO: /	PROFILO: / STATO: /

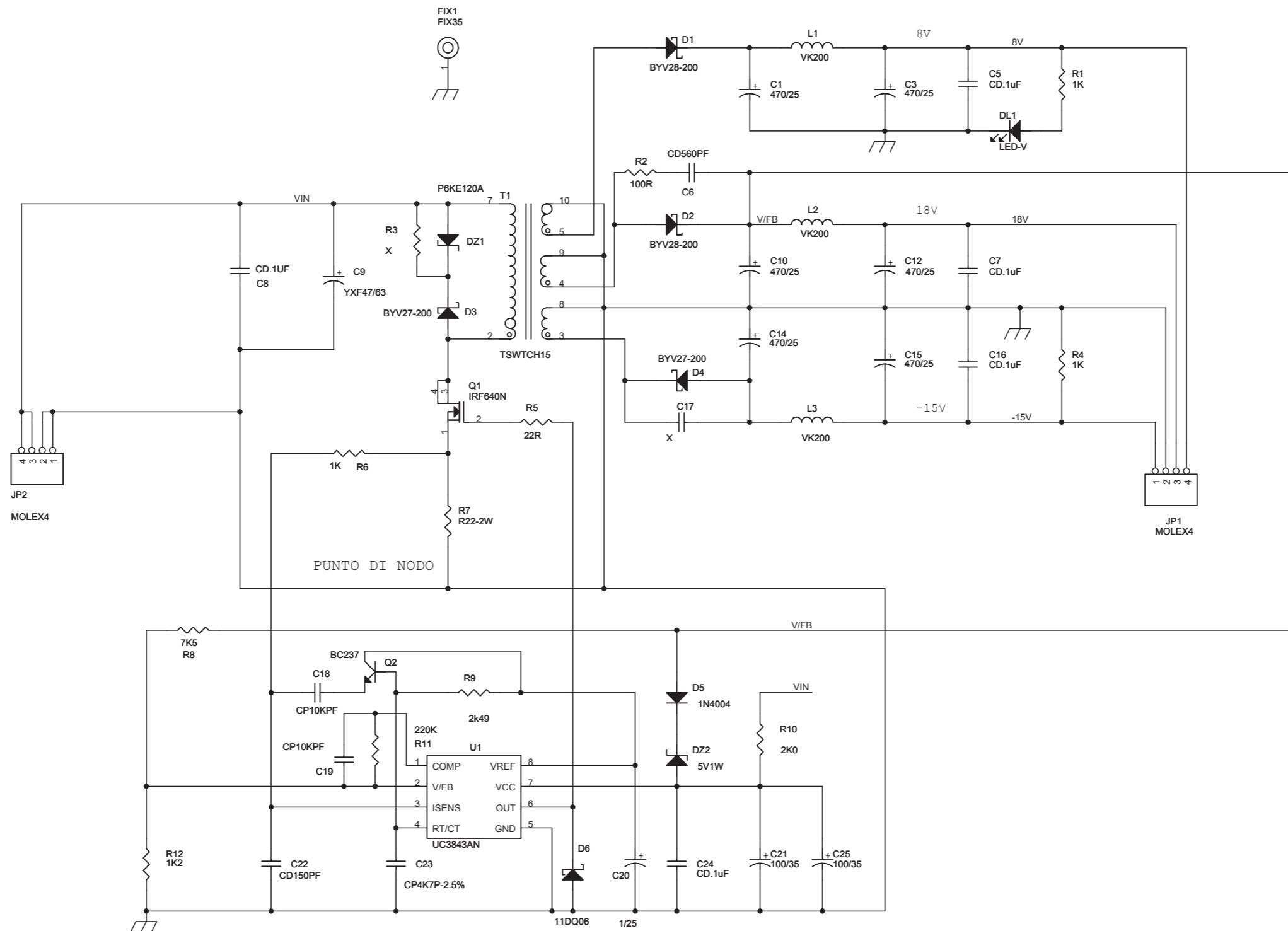

Nome Progetto: TEX300-LCD		Pagina: 1 di 1	Size: A3
Autore: GP - REV.: J.BERTI	Data: 24/03/2006	Codice Progetto: 045	
Nome PC in Rete: \UTSRV\	Revisione: 1.0	Nome Parte: POWER SUPPLY +18V1A 8V0.5A 15V 0.2	
File/Cartella: PSL600_AUS.DSN	Autorizzazione:	Codice: PSL600	

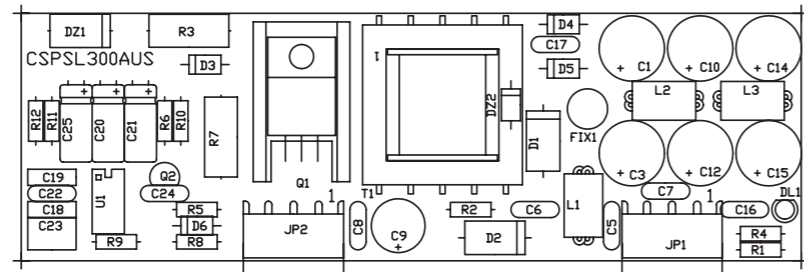

Revised: Friday, October 13, 2006
Revision:

Item	Quantity	Reference	Part
1	6	C1, C3, C10, C12, C14, C15	470/25
2	5	C5, C7, C8, C16, C24	CD.1uF
3	1	C6	CD560PF
4	1	C9	YXF47/63
5	2	R3, C17	X
6	2	C18, C19	CP10KPF
7	1	C20	25-gen
8	2	C21, C25	100/35
9	1	C22	CD150PF
10	1	C23	CP4K7P-2.5%
11	1	DL1	LED-V
12	1	DZ1	P6KE120A
13	1	DZ2	5V1W
14	2	D1, D2	BYV28-200
15	2	D3, D4	BYV27-200
16	1	D5	1N4004
17	1	D6	11DQ06
18	1	FIX1	FIX35
19	2	JP1, JP2	MOLEX4
20	3	L1, L2, L3	VK200
21	1	Q1	IRF640N
22	1	Q2	BC237
23	3	R1, R4, R6	1K
24	1	R2	100R
25	1	R5	22R
26	1	R7	R22-2W
27	1	R8	7K5
28	1	R9	2k49
29	1	R10	2K0
30	1	R11	220K
31	1	R12	1K2
32	1	T1	TSWTCH15
33	1	U1	UC3843AN

	NOME PROGETTO: TEX300LCD	NOME PARTE: Auxiliary Power Supply Card
	AUTORE: U.T. - rev.: J. Berti	DATA: 21/03/2006
ARCHIVIAZIONE ELETTRONICA: "CARTELLA PROGETTI" SU "UT_SRV"	CODICE PROGETTO: 045	REVISIONE: 1.0
MATERIALE: /	TRATTAMENTO: /	SCALA: 2:1
		SIZE: A4
		PAGINA: 1 DI 1
		CODICE DISEGNO: PSL600
		STATO: /

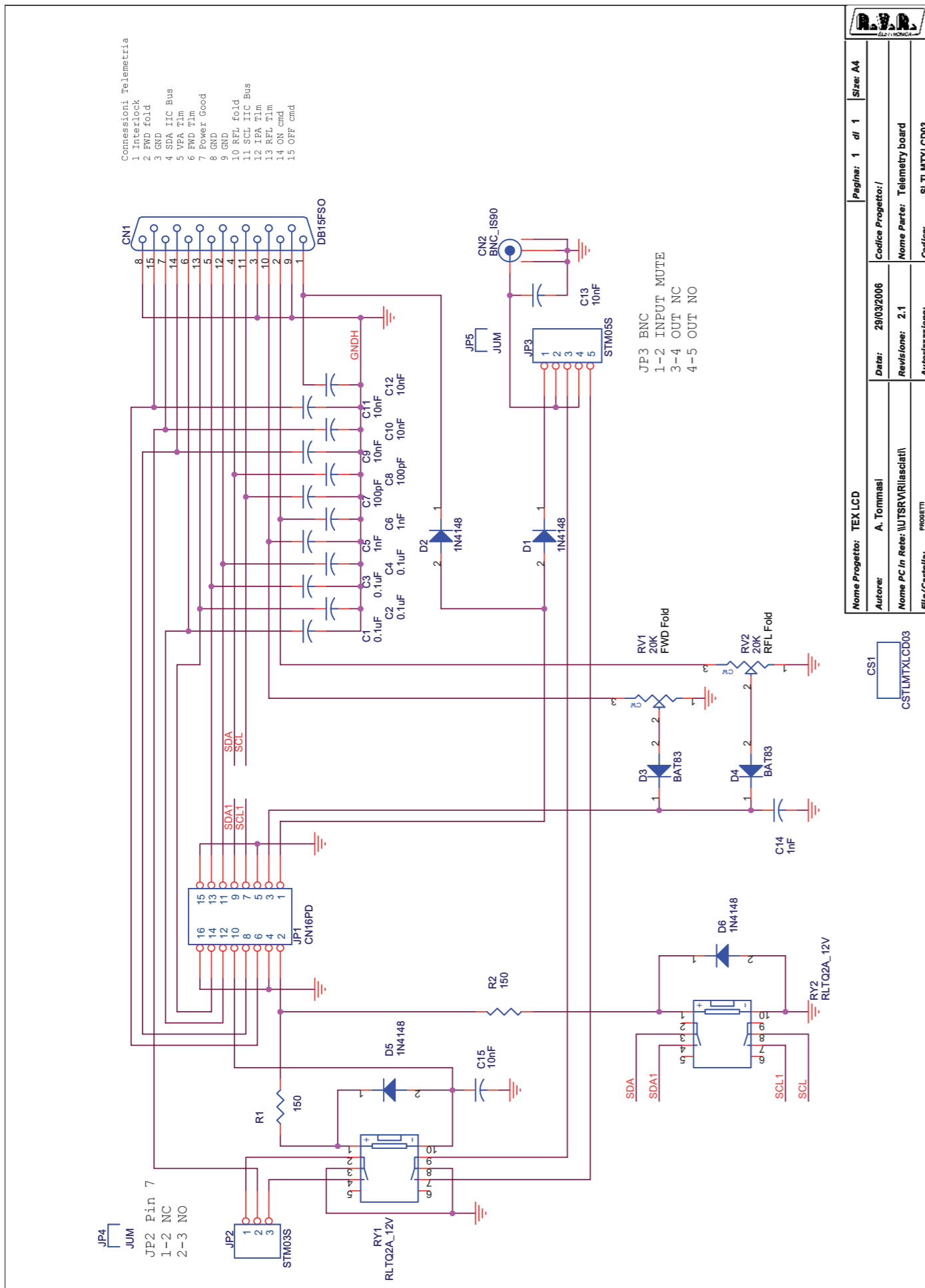

R.V.R. ELETTRONICA	
Nome Progetto: TEX LCD	Pagina: 1 di 1 Size: A4
Autore: A. Tommasi	Data: 29/03/2006 Codice Progetto: /
Nome PC in Rete: UTSRVRIasciati1	Revisione: 2.1 Nome Parte: Telemetry board
File/Cartella: prosem	Autore/azione: SLTLMTXLCD03

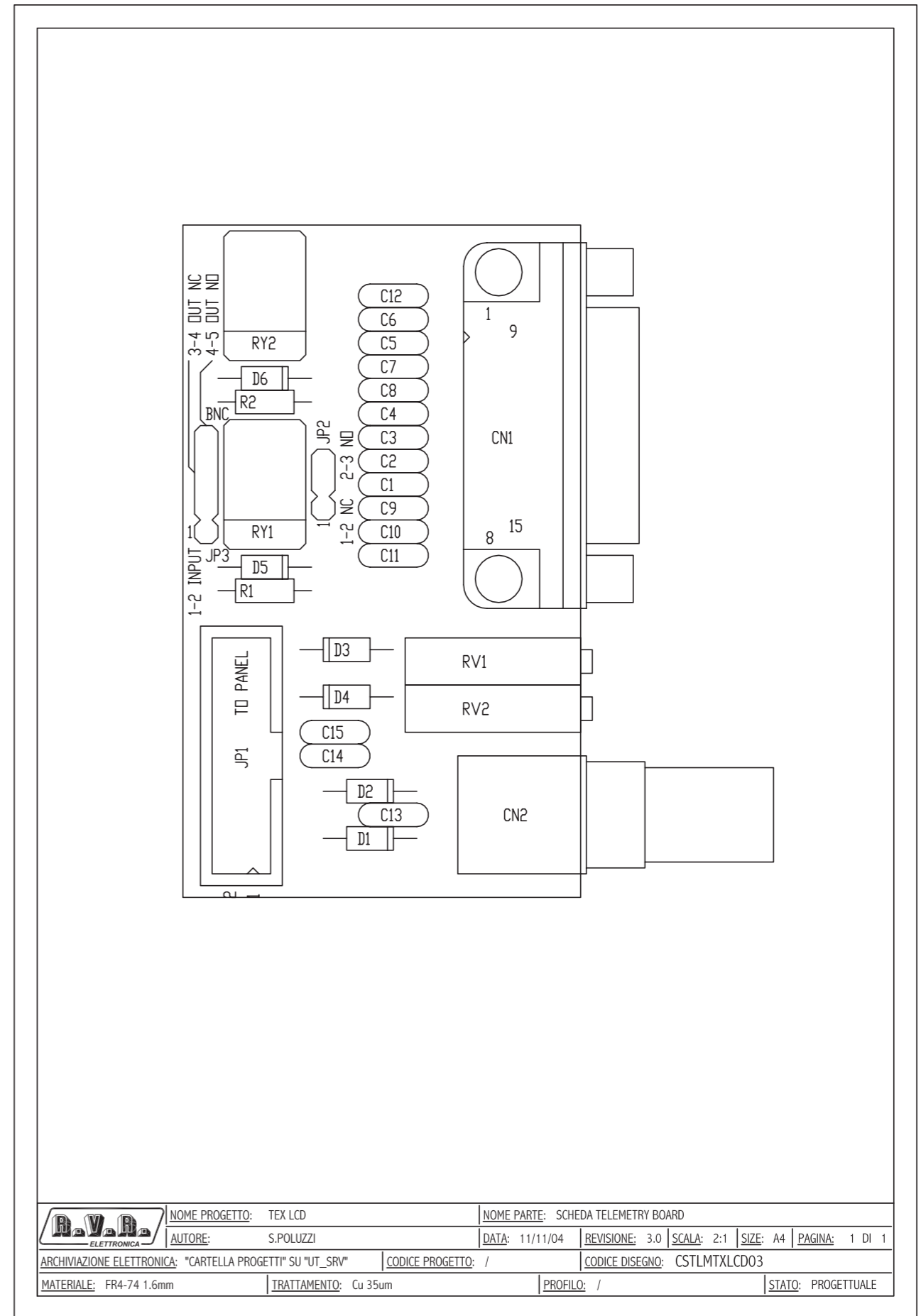

R.V.R. ELETTRONICA	Nome Progetto: TEX LCD	Nome Parte: SCHEDA TELEMETRY BOARD
Autore: S.POLUZZI	Data: 11/11/04	Revisione: 3.0 Scala: 2:1 Size: A4 Pagina: 1 DI 1
Archiviazione Elettronica: "CARTELLA PROGETTI" SU "UT_SRV"	Codice Progetto: /	Codice Disegno: CSTLMTXLCD03
Materiale: FR4-74 1.6mm	Trattamento: Cu 35um	Profilo: / Stato: PROGETTUALE

Telemetry board Revised: Wednesday, March 29, 2006
 SLTLMTXLCD03 Revision: 2.1
 TEX-LCD/RXRL-LCD/PTRL-LCD
 Andrea Tommasi

Item	Quantity	Reference	Part	Description
1	1	CN1	DB15FSO	Connettore DB15 femm. cs 90°
2	1	CN2	BNC_IS90	Connettore BNC metallico 90°
3	1	CS1	CSTLMTXLCD03	Circuito stampato
4	4	C1, C2, C3, C4	0.1uF	Cond. ceramico p 5mm
5	3	C5, C6, C14	1nF	Cond. ceramico p 5mm
6	2	C7, C8	100pF	Cond. ceramico p 5mm
7	6	C9, C10, C11, C12, C13, C15	10nF	Cond. ceramico p 5mm
8	4	D1, D2, D5, D6	1N4148	Diode in vetro DO35
9	2	D3, D4	BAT83	Diode Hot carrier DO35
10	1	JP1	CN16PD	Connettore 16 poli Flat cs
11	1	JP2	STM03S	Strip maschio 3 pin
12	1	JP3	STM05S	Strip maschio 5 pin
13	2	JP4, JP5	JUM	Ponticello Jumper Nota 1
14	2	RV1, RV2	20K	Trimmer Rg H 3006
15	2	RY2, RY1	RLTQ2A_12V	Rele' TQ2
15	2	R1, R2	150	Res. 1/4W