

---

---

# PWRMETER-D2



User Manual  
Volume 2: Technical Appendix

## Appendix A Piani di montaggio, schemi elettrici, liste componenti / *Component layouts, schematics, bills of material*

Questa parte del manuale contiene i dettagli tecnici riguardanti la costruzione delle singole schede componenti il PWRMETER-D2. L'appendice è composta dalle seguenti sezioni:

*This part of the manual contains the technical details about the different boards of the PWRMETER-D2. This appendix is composed of the following sections:*

<b>Description</b>	<b>RVR Code</b>	<b>Vers. Page</b>	
Wiring Diagrams	/		1
RMS RF Rectifier Board	SL172MT1001	1.0	2
Wattmeter Interface Board	SL172IN1001	1.0	4
Wattmeter Protection Board	PROTF172	1.0	6

### Document History

Date	Version	Reason	Code	Editor
17/10/2008	1.0	First Release	/	J.H. Berti

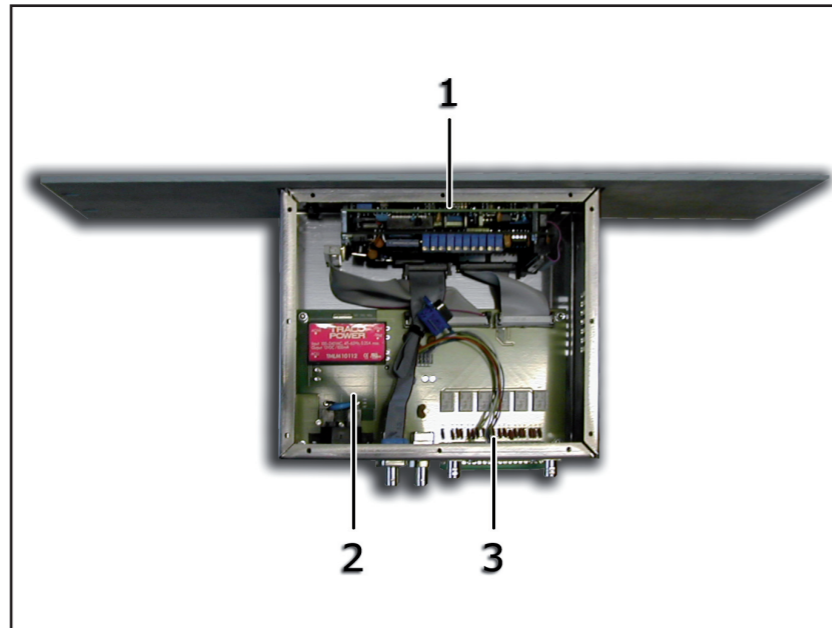

- [1] Scheda Protezioni Wattmetro (PROTF172)
- [2] Scheda Interfaccia Wattmetro (SL172IN1001)
- [3] Scheda Rettificatore RF RMS (SL172MT1001)

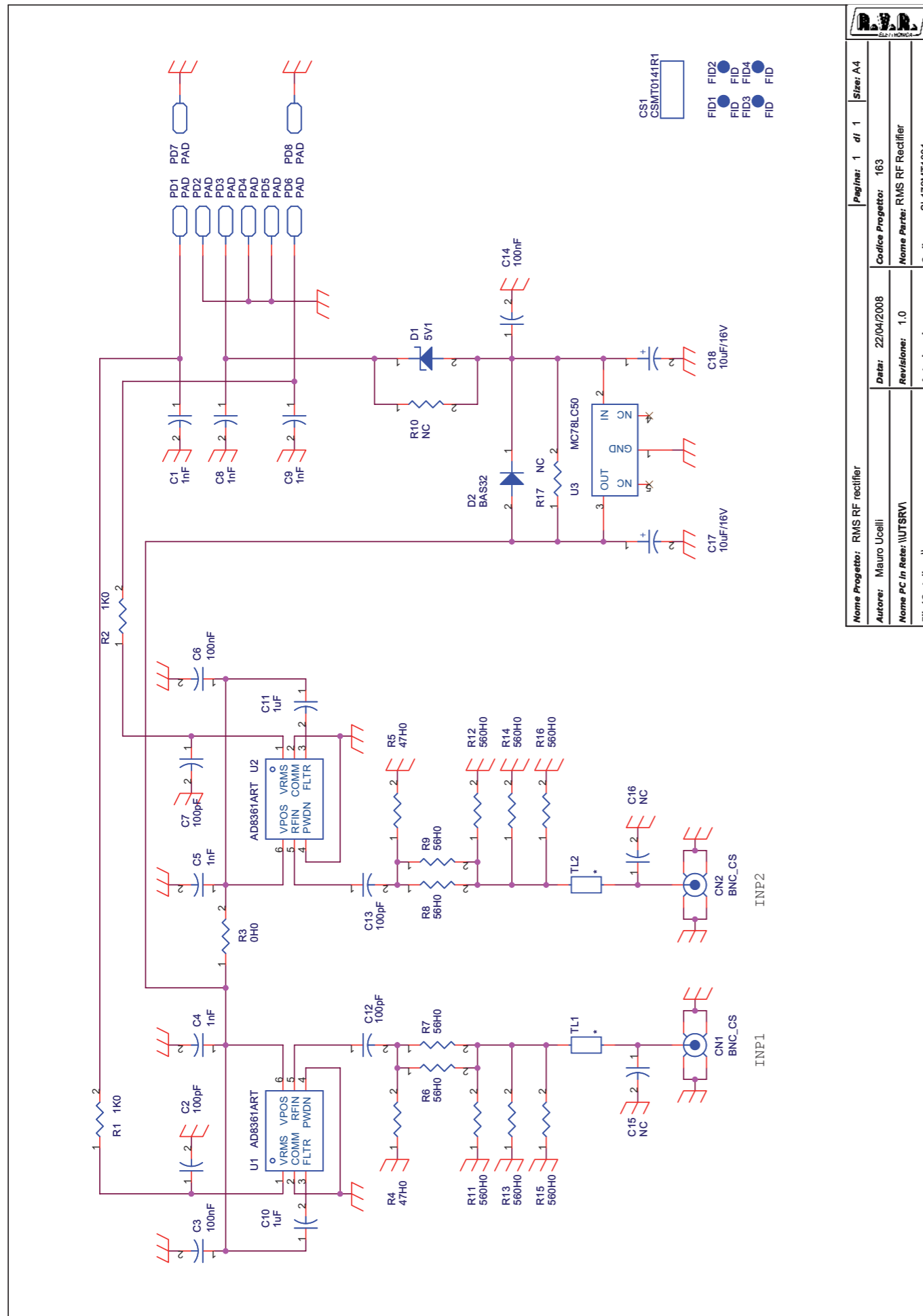

Nome Progetto: RMS RF rectifier		Pagina: 1 di 1		Size: A4	
Autore: Mauro Ucelli		Data: 22/04/2008		Codice Progetto: 163	
Nome PC In Rete: \UTSRV\		Revisione: 1.0		Nome Parte: RMS RF Rectifier	
File/Cartella: \		Autorizzazioni:		Codice: SL172MT1001	

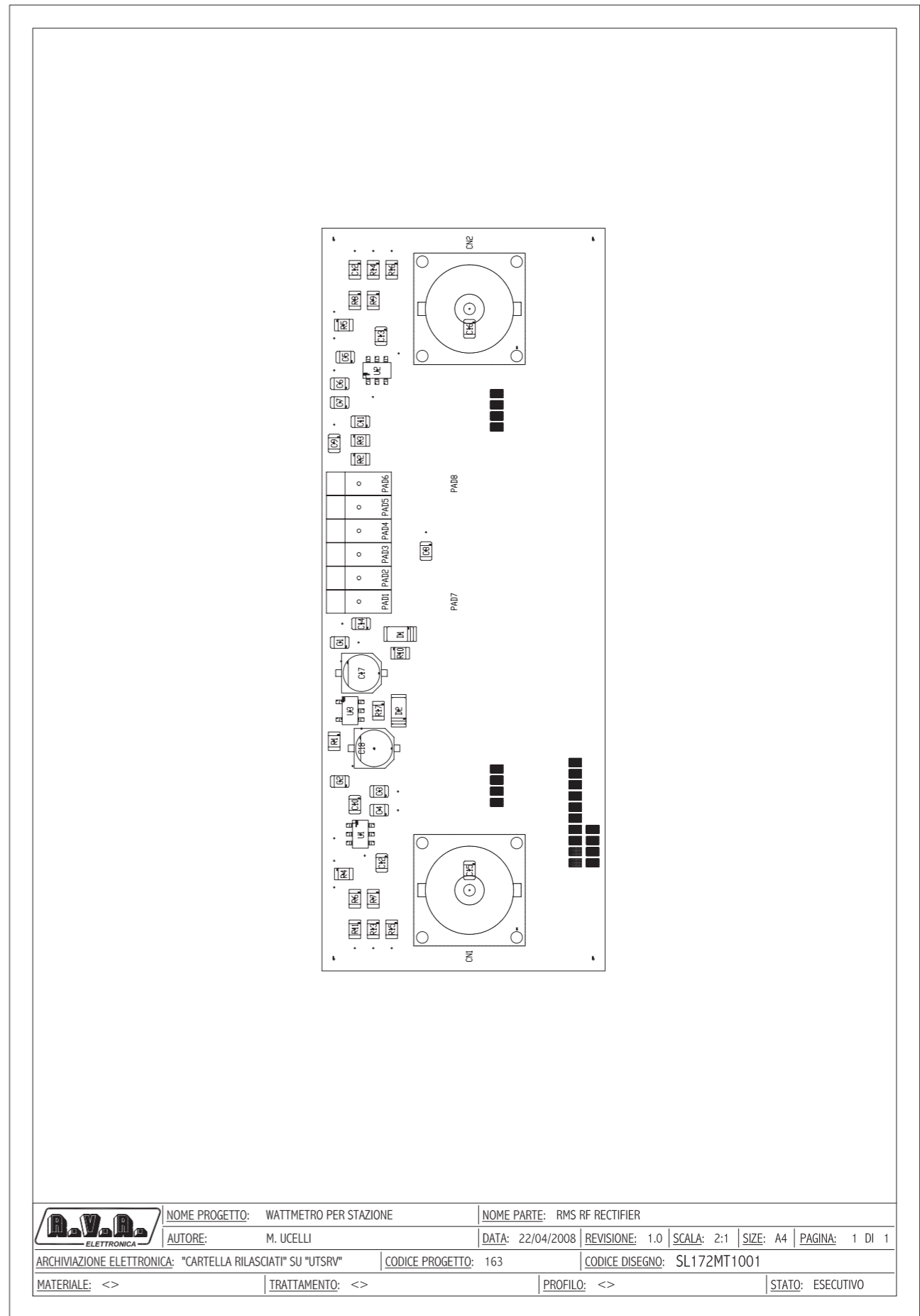

NOME PROGETTO: WATTMETRO PER STAZIONE		NOME PARTE: RMS RF RECTIFIER			
AUTORE: M. UCCELLI		DATA: 22/04/2008	REVISIONE: 1.0	SCALA: 2:1	SIZE: A4
ARCHIVIAZIONE ELETTRONICA: "CARTELLA RILASCIATI" SU "UTSRV"		CODICE PROGETTO: 163		CODICE DISEGNO: SL172MT1001	
MATERIALE: <>		TRATTAMENTO: <>		PROFILO: <>	
STATO: ESECUTIVO					

RMS RF Rectifier Revised: 22/04/2008  
 SL172MT1001 Revision: 1.0  
 RMS RF rectifier  
 163  
 Mauro Ucelli  
 08/06/07

Item	Quantity	Reference	Part	Description	Code
1	2	CN1,CN2	BNC_CS	Connettore BNC 10x10 cs	CNTBNCFCFS
2	1	CS1	CSMT0141R1	Circuito stampato	CSMT0141R1
3	5	C1,C4,C5,C8,C9	1nF	Cond. SMD 0805 COG	CCC085102GCC
4	4	C2,C7,C12,C13	100pF	Cond. SMD 0805 COG	CCC085101JCC
5	3	C3,C6,C14	100nF	Cond. SMD 0805	CCC085104KXC
6	2	C10,C11	1uF	Cond. SMD 0805	CCC085105KYC
7	2	C15,C16	NC	Cond. SMD 0805 COG	
8	2	C17,C18	10uF/16V	Cond. Elett. SMD d. 4mm	CES106A160
9	1	D1	5V1	MINIMELF SMD Zener Diode	DIZ5V1MINI
10	1	D2	BAS32	MINIMELF SMD Diode	DISBAS32MINI
11	4	FID1,FID2,FID3,FID4	FID	Fiducial CS	
12	8	PD1,PD2,PD3,PD4,PD5,PD6,PD7,PD8	PAD		
13	2	R1,R2	1K0	Res. SMD 0805 1%	RCH085F0001K
14	1	R3	0H0	Res. SMD 0805 1%	RCH085F0000H
15	2	R4,R5	47H0	Res. SMD 0805 1%	RCH085F0047H
16	4	R6,R7,R8,R9	56H0	Res. SMD 0805 1%	RCH085F0056H
17	2	R10,R17	NC	Res. SMD 0805 1%	
18	6	R11,R12,R13,R14,R15,R16	560H0	Res. SMD 0805 1%	RCH085F0560H
19	2	TL1,TL2	*	Linea strip CS	
20	2	U1,U2	AD8361ART	RMS RF Detector	CILAD8361ART <b>Nota 1</b>
21	1	U3	MC78LC50	Stab. SMD SOT23-5	CIL78LC05 <b>Nota 1</b>

**Nota 1** Da acquistare

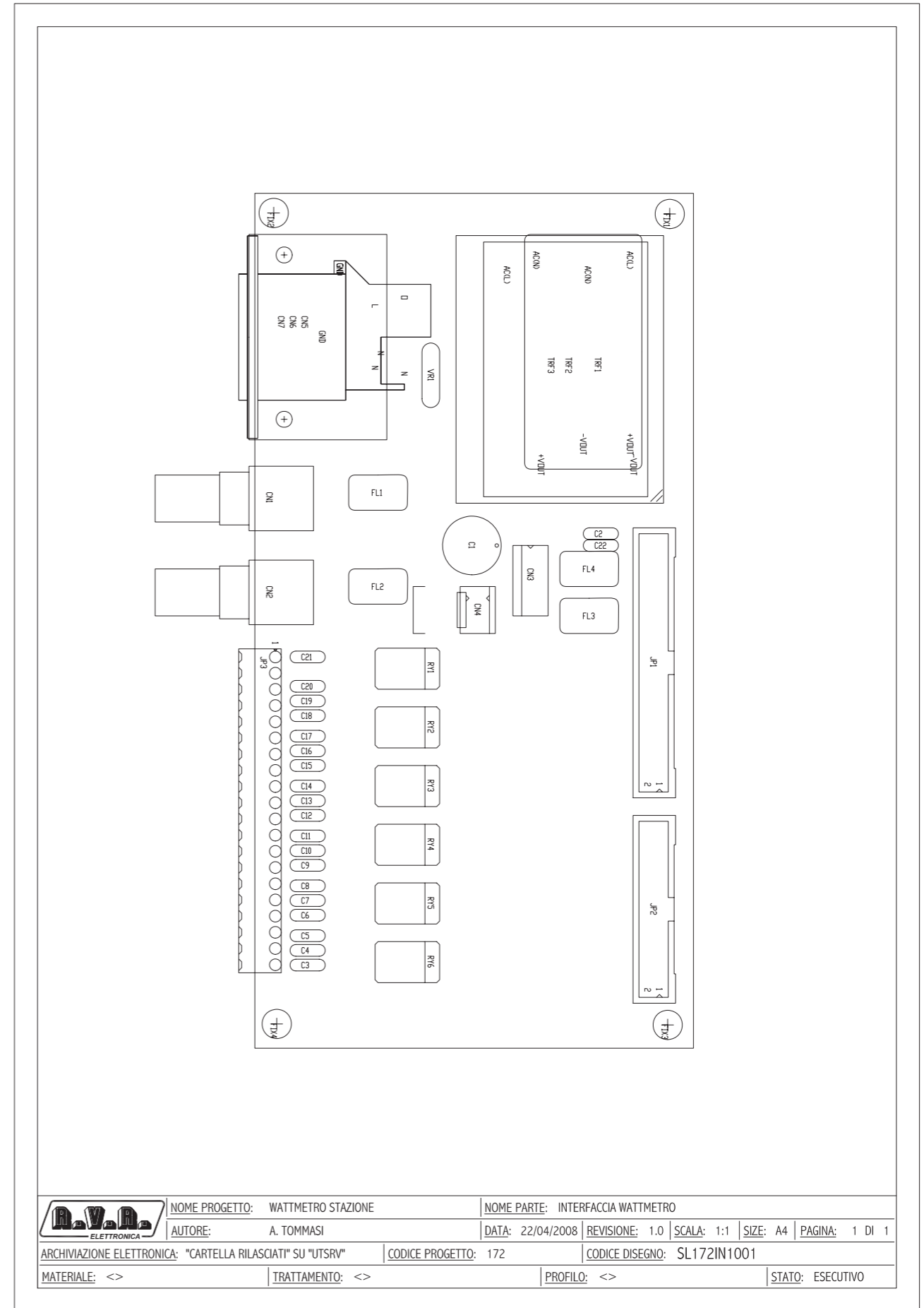
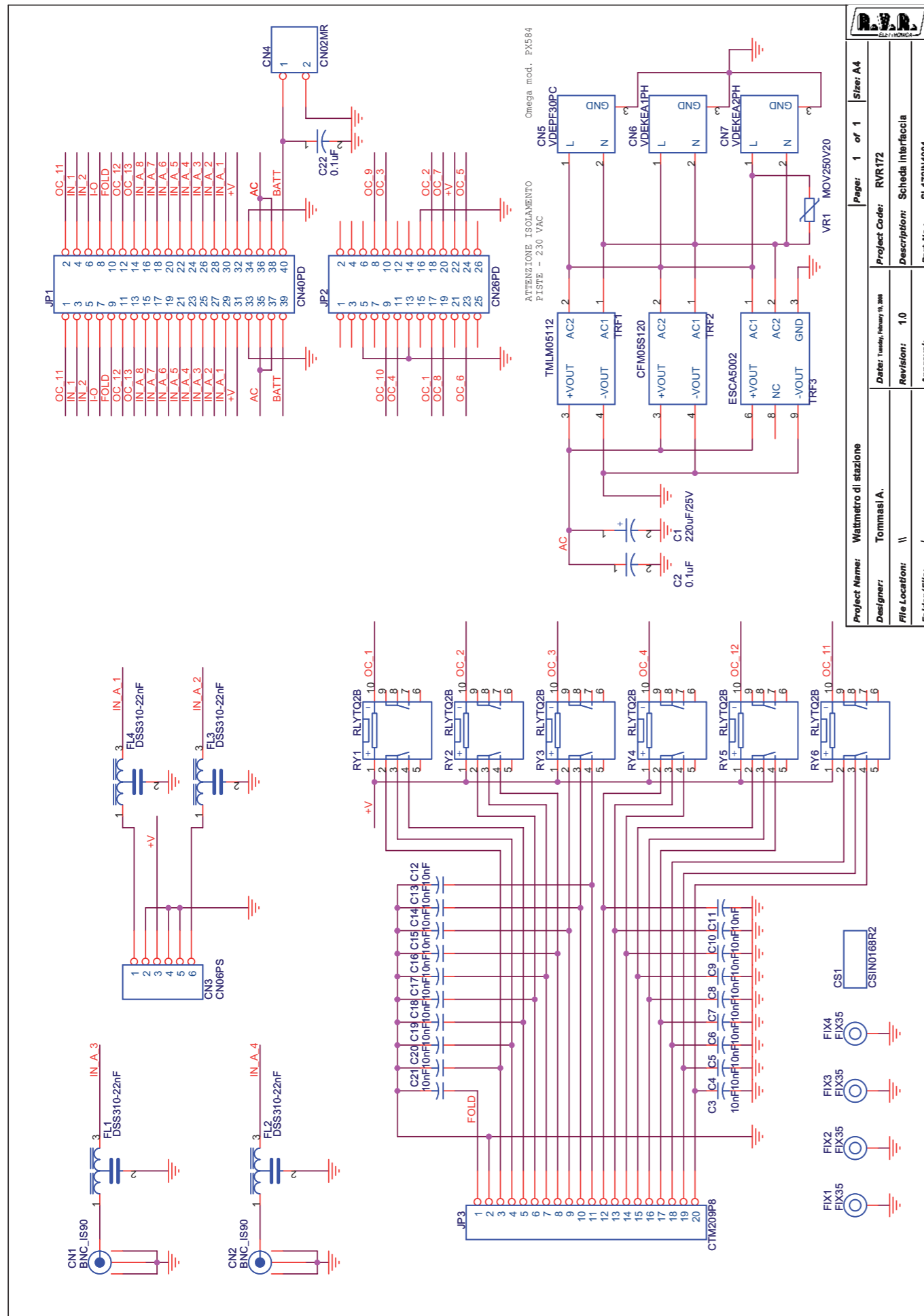

Scheda interfaccia Revised: Tuesday, February 19, 2008  
 SL172IN1001 Revision: 1.0  
 A. Tommasi  
 Wattmetro di stazione  
 RVR172

Item	Quantity	Reference	Part	Description	Code	
1	2	CN1,CN2	BNC_IS90	Connettore BNC metallico 90°	CNTBNCFCMSA	
2	1	CN3	CN06PS	Connettore 6 poli Mascon	CNTMASM6PCS	
3	1	CN4	CN02MR	Connettore Lumberg KB p. 5mm 2 pin	CNTMCS2P	
4	1	CN5	VDEPF30PC	Conn. VDE con portafusibili	CNTVDEMCSPFA	
5	1	CN6	VDEKEA1PH	Conn. VDE con portafusibili	CNTVDEKEA1PH	<b>NOTA 1</b>
6	1	CN7	VDEKEA2PH	Conn. VDE con portafusibili	CNTVDEKEA2PH	<b>NOTA 1</b>
7	1	CS1	CSIN0168R2	Circuito stampato	CSIN0168R2	
8	1	C1	220uF/25V	Cond. Elettr. Dia 13 P5.08	CEA227MA250	
9	2	C2,C22	0.1uF	Cond. ceramico p 5mm	CKM104KC600P	
10	19	C3,C4,C5,C6,C7,C8,C9,C10,C11,C12,C13,C14,C15,C16,C17,C18,C19,C20,C21	10nF	Cond. ceramico p 5mm	CKM103KC600P	
11	4	FIX1,FIX2,FIX3,FIX4	FIX35	Foro fissaggio 3.5mm		
12	4	FL1,FL2,FL3,FL4	DSS310-22nF	Filtro EMI Murata DSS310	FEA55F223500	
13	1	JP1	CN40PD	Conn.M.C.S.Dritto 40P alette	CNTMCS40A	
14	1	JP2	CN26PD	Connettore 26 poli Flat cs	CNTMCS26A	
15	1	JP3	CTM209P8	Conn. Sauro 20 poli CS 90° p. 3.5mm	CNTMCS20PAB	<b>NOTA 3</b>
16	6	RY1,RY2,RY3,RY4,RY5,RY6	RLYTQ2B	Rele' TQ2	RLD2V12V05AM	
17	1	TRF1	TMLM05112	AC-DC Conv. 5W	MIBTMLM	<b>NOTA 2</b>
18	1	TRF2	CFM05S120	AC-DC Conv. 5W	PSSWACDC5W12V	
19	1	TRF3	ESCA5002	AC-DC Conv. 5W	MIBESCA5	<b>NOTA 2</b>
20	1	VR1	MOV250V20	Varistor dia. 14mm	MOV250V20	

**NOTA 1** Codici alternativi a CN5, se ne monta solo 1

**NOTA 2** Codici alternativi a TRF2, se ne monta solo 1

**NOTA 3** Da acquistare coppia M e F  
 Sauro CTM209P8  
 Sauro CTF20008

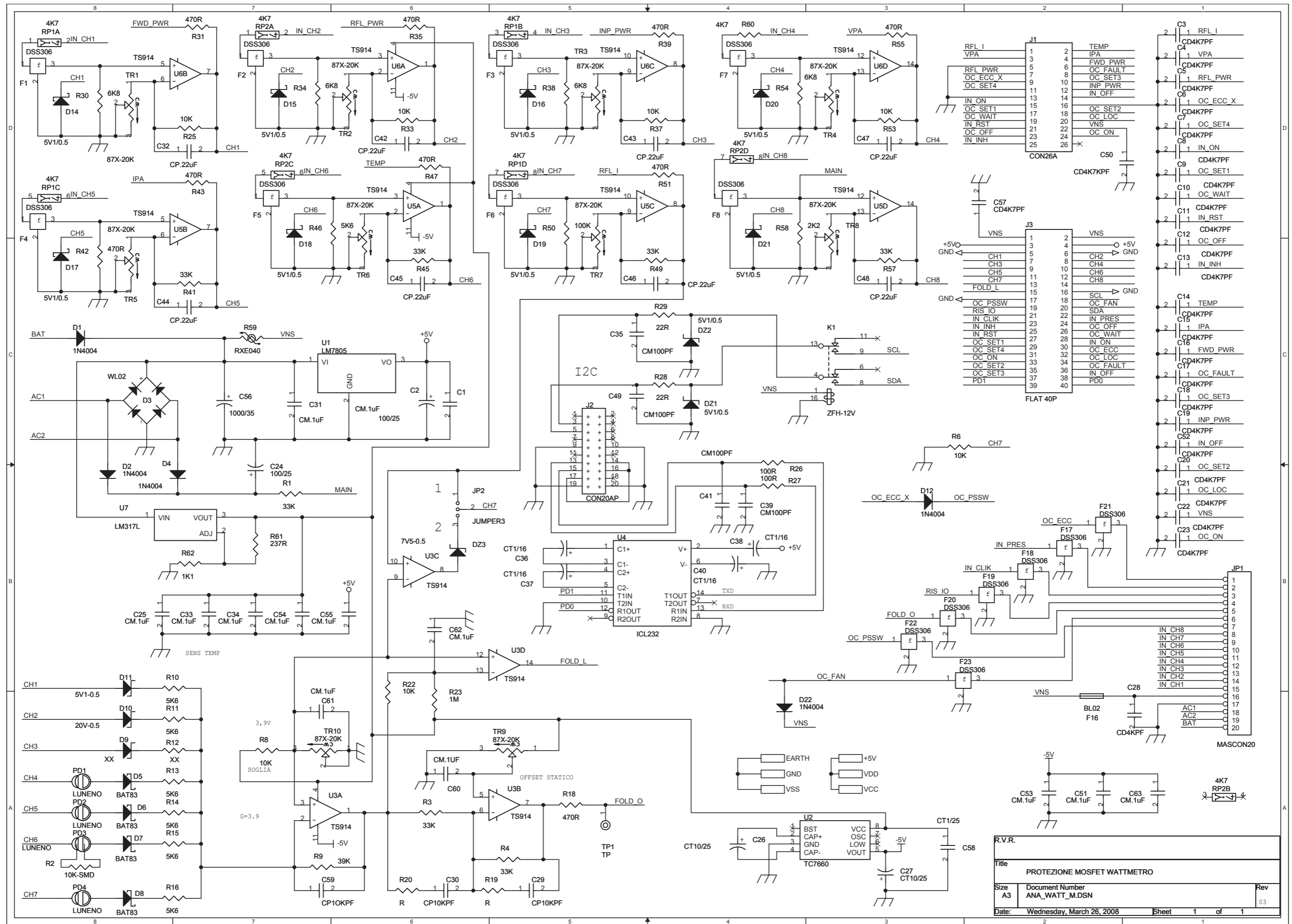

R.V.R.		
Title PROTEZIONE MOSFET WATTMETRO		
Size A3	Document Number ANA_WATT_M.DSN	Rev 03
Date: Wednesday, March 26, 2008	Sheet 1 of 1	



PIANO DI MONTAGGIO CSPROTSSAE02 WATTMETRO

DARE UN PUNTO CON LA COLLA A CALDO

IL FORD DI FISSAGGIO DEL T0220 DEVE COLLIMARE CON IL FORD C.S.

MONTARE ALTEZZA CONDENSATORI ELETTROLITICI

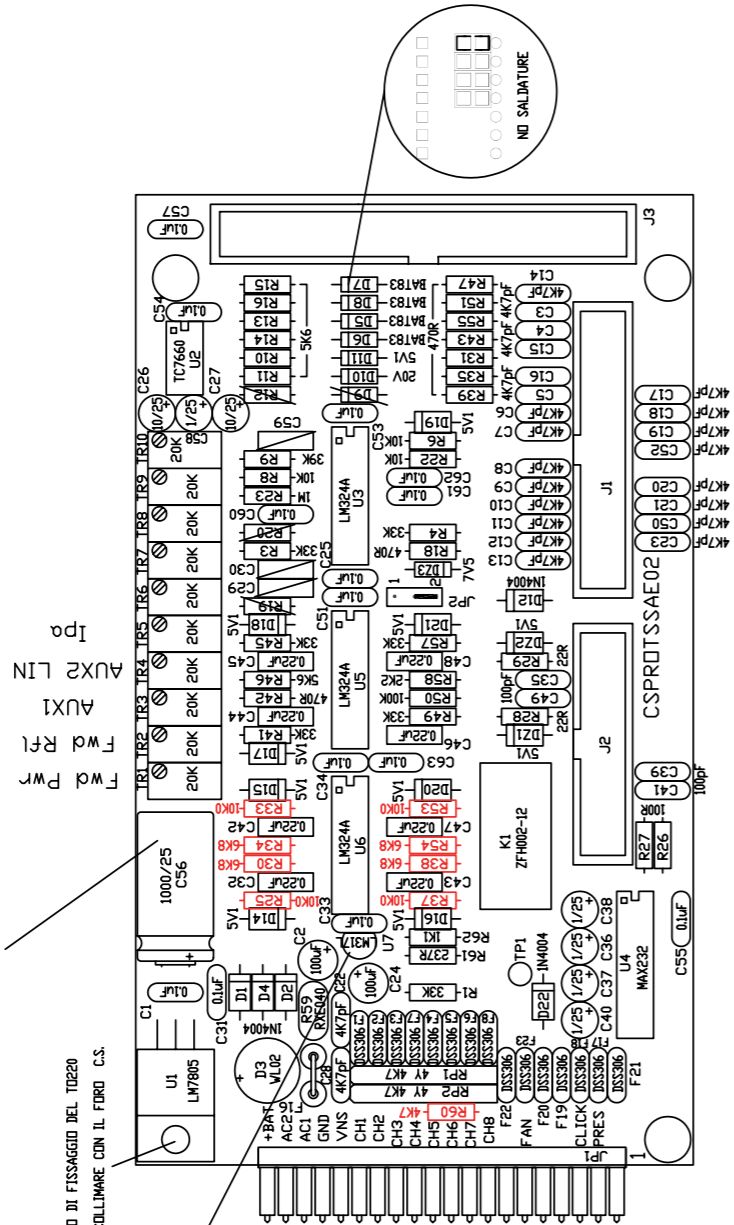

TITLE	PIANO DI MONTAGGIO PROTEZIONE MOSFET ANALOGICA
DOCUMENT NUMBER	ANA_WATT_M_DWG
DATE:	26 marzo 2008
REV	1

PROTEZIONE MOSFET WATTMETRO Revised: Wednesday, March 26, 2008  
 ANA\_WATT\_M.DSN Revision: ?  
 R.V.R.

Item	Quantity	Reference	Part
1	13	C1, C25, C31, C33, C34, C51, C53, C54, C55, C60, C61, C62, C63	CM.1uF
2	2	C2, C24	100/25
3	23	C3, C4, C5, C6, C7, C8, C9, C10, C11, C12, C13, C14, C15, C16, C17, C18, C19, C20, C21, C22, C23, C52, C57	CD4K7PF
4	2	C26, C27	CT10/25
5	1	C28	CD4KPF
6	2	C29, C30	CP10KPF
7	8	C32, C42, C43, C44, C45, C46, C47, C48	CP.22uF
8	4	C35, C39, C41, C49	CM100PF
9	4	C36, C37, C38, C40	CT1/16
10	1	C50	CD4K7KPF
11	1	C56	1000/35
12	1	C58	CT1/25
13	1	C59	CP10KPF
14	10	DZ1, DZ2, D14, D15, D16, D17, D18, D19, D20, D21	5V1/0.5
15	1	DZ3	7V5-0.5
16	5	D1, D2, D4, D12, D22	1N4004
17	1	D3	WL02
18	4	D5, D6, D7, D8	BAT83
19	2	D9, R12	XX
20	1	D10	20V-0.5
21	1	D11	5V1-0.5
22	15	F1, F2, F3, F4, F5, F6, F7, F8, F17, F18, F19, F20, F21, F22, F23	DSS306
23	1	F16	BL02
24	1	JP1	MASCON20
25	1	JP2	JUMPER3
26	1	J1	CON26A
27	1	J2	CON20AP
28	1	J3	FLAT 40P
29	1	K1	ZFH-12V
30	4	PD1, PD2, PD3, PD4	LUNENO
31	3	RP1, RP2, R60	4K7
32	7	R1, R3, R4, R41, R45, R49, R57	33K
33	1	R2	10K-SMD
34	7	R6, R8, R22, R25, R33, R37, R53	10K
35	1	R9	39K
36	7	R10, R11, R13, R14, R15, R16, R46	5K6
37	9	R18, R31, R35, R39, R42, R43, R47, R51, R55	470R
38	2	R19, R20	R
39	1	R23	1M
40	2	R26, R27	100R
41	2	R28, R29	22R
42	4	R30, R34, R38, R54	6K8
43	1	R50	100K
44	1	R58	2K2
45	1	R59	RXE040
46	1	R61	237R
47	1	R62	1K1
48	1	TP1	TP
49	10	TR1, TR2, TR3, TR4, TR5, TR6, TR7, TR8, TR9, TR10	87X-20K
50	1	U1	LM7805
51	1	U2	TC7660
52	3	U3, U5, U6	TS914
53	1	U4	ICL232
54	1	U7	LM317L



PIANO DI MONTAGGIO LATO SALDATURE WATTMETRO

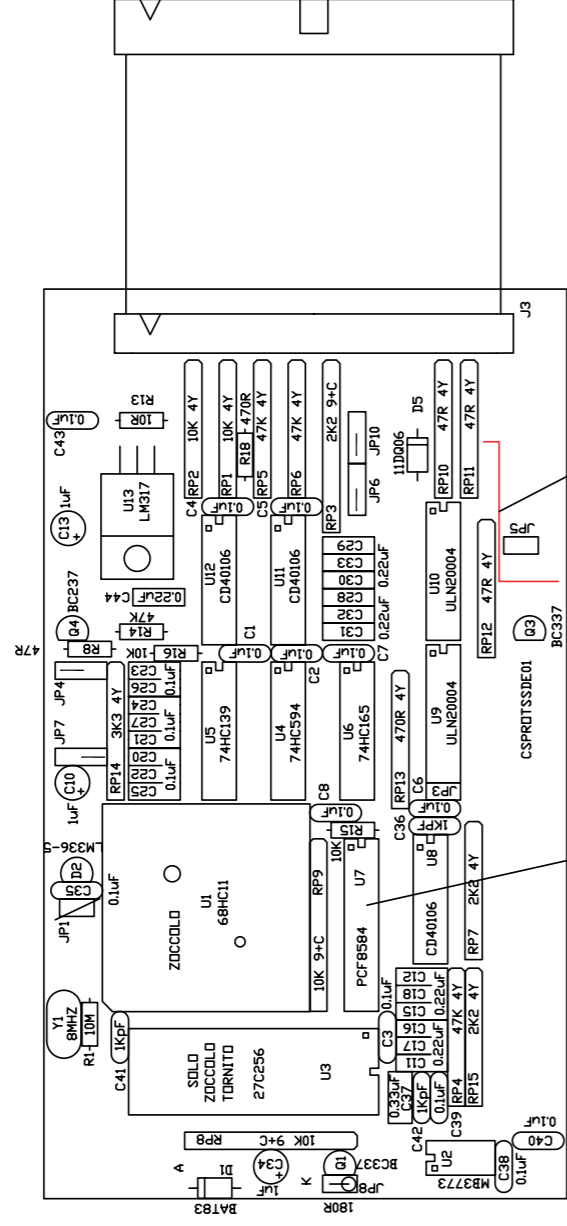

MONTARE CON ZOCCOLO

COLLEGAMENTO  
FILO  
WIRE-WRAP

TITLE	PIANO DI MONTAGGIO CPU_MDS
DOCUMENT NUMBER	CPU_WATT_M.DWG
DATE:	26 MARZO 2008
REV	

**MONTAGGIO LED  
WATTMETRO**

UTILIZZARE DIMA DI MONTAGGIO  
PER IL MONTAGGIO DEI LED

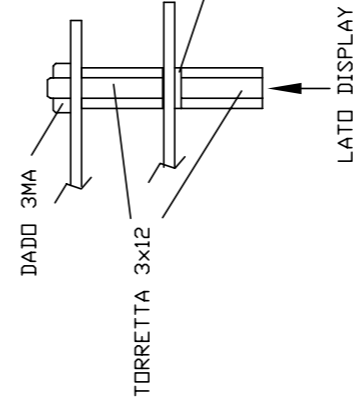

SOLUZIONE PRIVILEGIATA

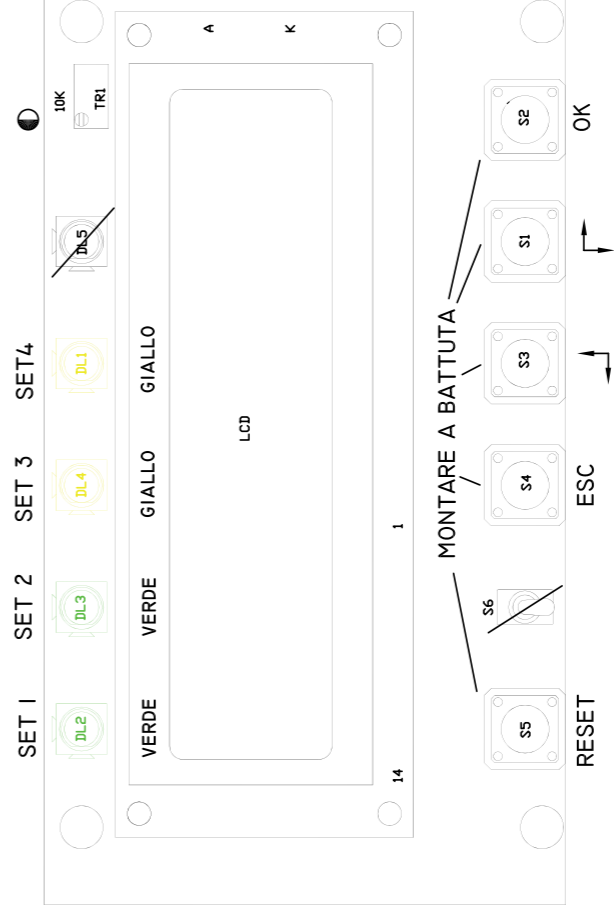
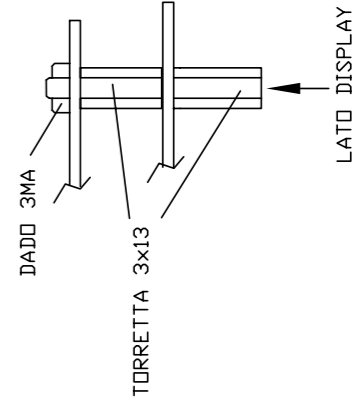

MONTARE A BATTUTA

TITLE	PIANO DI MONTAGGIO CPU_MDS
DOCUMENT NUMBER	CPU_WATT_M.DWG
DATE:	26 MARZO 2008
REV	

CPU WATTMETRO Revised: Wednesday, March 26, 2008  
 CPU\_WATT\_M.DSN Revision: ?  
 R.V.R ELETTRONICA

Item	Quantity	Reference	Part
1	13	C1, C2, C3, C4, C5, C6, C7, C8, C35, C38, C39, C40, C43	CM.1uf
2	3	C10, C13, C34	CT1/16
3	13	C11, C12, C15, C16, C17, C18, C28, C29, C30, C31, C32, C33, C44	CP.22uF
4	8	C20, C21, C22, C23, C24, C25, C26, C27	CP.1uF
5	3	C36, C41, C42	CD1KpF
6	1	C37	CP.33uF
7	1	DL1	L5Y
8	1	DL2	L5V
9	1	DL3	L5G
10	1	DL4	L5R
11	2	DL5, S6	X
12	1	D1	BAT84
13	1	D2	LM336-5.0V
14	1	D5	11DQ06
15	3	JP1, JP3, JP5	JUMP2
16	1	JP2	STRIP 14
17	4	JP4, JP6, JP7, JP10	JUMPER3
18	1	JP8	180R
19	1	JP9	STRIP 2
20	1	J3	FLAT 40P
21	3	Q1, Q3, Q4	BC337
22	6	RP1, RP2, RP8, RP9, R15, R16	10K
23	3	RP3, RP7, RP15	2K2
24	4	RP4, RP5, RP6, R14	47K
25	4	R8, RP10, RP11, RP12	47R
26	2	RP13, R18	470R
27	1	RP14	3K3
28	1	R1	10M
29	1	R13	10R
30	5	S1, S2, S3, S4, S5	SW
31	1	TR1	87W-10K
32	1	U1	68HC11F1
33	1	U2	MB3773
34	1	U3	27C256
35	1	U4	74HC594
36	1	U5	74HC139
37	1	U6	74HC165
38	1	U7	PCF8584
39	3	U8, U11, U12	40106
40	2	U9, U10	ULN2004A
41	1	U13	LM317
42	1	Y1	CST-8MhZ