

FM30

FM EXCITER/TRANSMITTER

TECHNICAL MANUAL

CONTENTS

1	Introduction
2	Safety, Electrical hazard
3	Safety, Toxic hazard
4	Unpacking
5	Controls and Connectors
6	Installation
7	Block diagram
8	Specifications
9	Contacting sbs
10	Technical Section Contents
11	Declaration of conformity

No part of this manual may be reproduced or transmitted in any form or by any means, electronic or mechanical, including photocopying, recording or information storage and retrieval systems, for any purpose other than the purchaser's personal use, without the express written permission of sbs.

Information in this document is subject to change without notice and does not represent a commitment on the part of sbs. sbs shall not be liable for any direct, indirect, consequential or incidental damages as a result of the use or misuse of this equipment, handbook or any related materials.

1 Introduction

))

The FM30 is a top specification broadcast FM exciter that is also ideally suited as a low power stand alone transmitter. Featuring wideband design techniques, frequency adjustment is easily achieved by internally set direct reading dial switches - no further tuning is required. The FM30 uses the renowned sbs ultra linear modulator to give superb sound reproduction with freedom from overshoots and artifacts. It will operate into any load without damage thanks to its VSWR cut back circuit that protects the power amplifier stage from adverse operating conditions.

The FM30 front panel metering shows forward and reflected power together with internal voltages and the modulation level. Additionally monitor points for both audio multiplex/composite input and RF output are provided. Quick-view status monitoring using dual colour LEDs indicate that PLL lock, forward power and reflected power are within a preset tolerance when green. The rear panel includes a remote control/monitoring socket that allows carrier muting and status signalling to an external system.

Very conservatively rated components and a switch mode DC-DC converter are used to ensure extremely high reliability and to give good efficiency. The FM30 is in service with broadcasters worldwide and has been giving many years of trouble-free service.

The FM30 is built, together with the MPX5 Stereo Encoder as a transmission system, to exceed the requirements of ETSI 300 384: January 1995, Radio broadcasting systems standard for VHF FM sound broadcasting transmitters, specifying equipment for radio transmission.

2 Safety, Electrical hazard
))

This unit contains high voltages which could be fatal. YOU MUST ALWAYS ISOLATE THE UNIT FROM THE AC SUPPLY BY COMPLETELY DISCONNECTING IT BEFORE ATTEMPTING TO OPEN THE CASE.

THIS EQUIPMENT MUST BE EARTHED.

Do not expose this equipment to rain or any other source of water.

In common with all AC operated equipment, only suitably trained competent personnel should attempt to adjust, modify or repair this equipment or operate it with the cover removed. In case of query please contact your local agent or sbs.

Any unauthorised adjustment, modification or repair of this equipment may invalidate any warranty and/or safety approvals that apply.

Please read all of this manual and familiarise yourself with the controls before attempting to use this equipment.

To ensure safety, it is the responsibility of the user to install and operate this equipment in a manner that is within the manufacturers specifications.

3 Safety, Toxic hazard

))

This equipment includes devices which contain Beryllium Oxide which is a highly toxic substance. Inhalation or ingestion of even tiny particles could be injurious to health or even FATAL!

Extreme care must be exercised when replacing and discarding components which may contain Beryllium Oxide. If any such device is physically damaged you should seek expert advice, e.g. by contacting the device's manufacturers.

All such devices must be disposed of in accordance with local regulations. In the UK your local council will have a toxic waste disposal department who will be able to advise you. Elsewhere you should contact the responsible authorities.

NEVER DISPOSE OF A DEVICE CONTAINING BERYLLIUM OXIDE WITH GENERAL WASTE.

4 Unpacking

))

This package should contain:-

- 1x FM30 Series broadcast exciter/transmitter
- 1x IEC Power lead
- 1x FM30 series manual

If any items are missing or damaged please inform your supplier immediately.

Initial Checks

Ensure that the FM30 has been set to the correct power/line voltage for your country.

5 Controls and Connectors

))

Front Panel:

PLL LOCK	Modulator functioning correctly (when green).
P.FWD	Green when the RF output level is above a predetermined level (see installation section).
P.REF	Green while the reflected RF power is below a predetermined level (see installation section). Red when the VSWR cut-back system is operating.
LIMIT	Shows green when internal limiter option is limiting audio input level.
O/P Monitor	Monitor of RF output (approx. -40dB). This point should not be used for harmonic measurements.
Meter and selector	Selects and indicates important FM30 parameters.

Rear Panel:

Audio input	Unbalanced on BNC female connector or balanced on female XLR connector with optional limiter/encoder (pin 1 ground, pin 2 hot, pin 3 cold).
Multiplex/composite loop	With switch in ON position, the output of the limiter/stereo encoder (if fitted) can be routed via an external system such as an RDS/SCA encoder. With the switch in the OFF position, the multiplex/composite output of the limiter/encoder is present on the unbuffered output connector, but the input connector is disconnected.
Monitor	<p>25 way female D-type connector.</p> <ul style="list-style-type: none">Pin 1 Forward power alarm.Pin 2 Reverse power alarm.Pin 3 PLL lock alarm.Pin 4 Mute RF output (link to ground).Pin 5 - 14 Reserved.Pin 25 Ground. <p>All outputs are open collector and low in their normal state. The output transistors are BC184L's, which can sink up to 100mA maximum with an absolute maximum switched voltage of 30V.</p>
RF Out	N type female connector.
DC IN	4 pin XLR male, pin 1 and 2 negative, 3 and 4 positive.
AC Mains	Filtered IEC male connector with fuse in pull out drawer. T2A for 220-240V/T3.15A for 100-120V.

6 Installation

))

RF leads should be made from high quality low loss cable and connectors of the correct impedance, using the manufacturers recommended termination techniques. Since connectors are a source of un-reliability in any system, the number of terminations in any RF lead should be kept to a minimum.

All other cables for audio and control signals should be high quality screened types. For XLR connectors, the screen should be connected to the connector body.

Before normal operation of the FM30 can commence the following parameters will require setting, assuming the equipment supplier has not done so:

- 6.1 Frequency
- 6.2 Output power
- 6.3 Forward power alarm
- 6.4 Modulator input level
- 6.5 VSWR Cut-back level

Please read through ALL of the following stages before attempting any adjustment. When an automatic change over system is in use (such as the ACU2) this should be disconnected/overridden such that the FM30 operates continuously during the set-up procedure.

6.1 FREQUENCY SETTING

Setting the frequency is a simple operation and may, if required be performed with the unit in operation (though only with a dummy load connected to the output).

For example, to set a frequency of 97.30MHz, set the 100MHz dial to 0, the 10MHz dial to 9, the 1MHz dial to 7, the 100kHz dial to 3 and the 50kHz shift switch to OFF. If the 50kHz switch was set to ON the output frequency would be 97.35MHz.

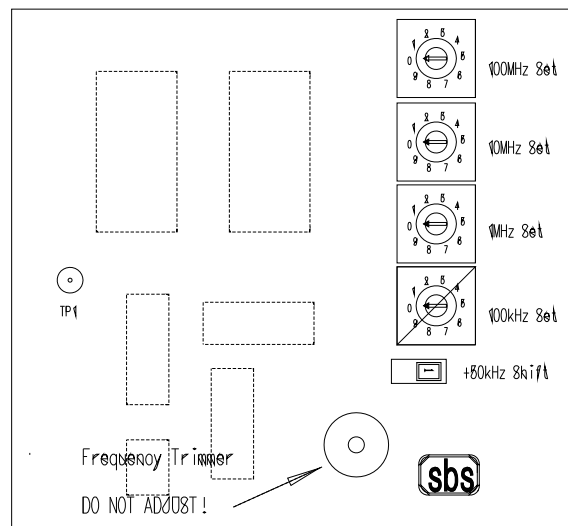

Figure 1 PLL3 Digital board.

Whilst the Phase Locked Loop is Locking up the modulator output is muted (indicated by the front panel PLL LOCK LED). When the FM30 is either powered up or the frequency changed, it will normally take about 5 seconds for the PLL to lock up. However if the frequency is changed from a high one to one at the bottom of band two, with the unit in operation, it can take up to 10 seconds for the PLL to lock up properly.

6.2 OUTPUT POWER

A small trimmer tool or precision screwdriver will be required to adjust the output power.

The output power should ideally be set using an accurate power meter connected to the RF output which in turn should be connected to an adequately rated dummy load. If either of these items are not available then the front panel meter could be used and/or it could be operated into the aerial or PA stage. In this latter case the Output Power control (rear panel) should be set to minimum (counter clockwise) before powering up the FM30.

Connect the FM30 to the mains or DC supply and wait for the PLL to LOCK (the front panel LED indicates lock when green). Using the rear panel power adjust control (PWR. ADJ.) set the power to that required.

6.3 FORWARD POWER ALARM

This setting defines the point at which the front panel P. FWD. light changes to red and also the point at which a forward power fault is indicated at the Control/Monitor socket (for telemetry and/or operation of an automatic change over system). Adjust the output power to the fault level required. This must always be less than the normal output power level by enough to prevent spurious triggering, 1dB is an appropriate margin (80% of the correct full power). Adjust the P FWD OK (RV4) control on the FM25-DIS board such that the front panel P. FWD. light just turns red from green. Finally set the output power back to the normal output level.

6.4 MODULATOR INPUT LEVEL

For FM30/M and FM30/S see sections below covering LimX or DLM3 PCB's.

The FM30 is normally supplied with the modulator input level set so that an input level of +8dBu over the range 5Hz to 100kHz (without pre-emphasis) gives a deviation of 75kHz. If a different level is required then it will be necessary to reset the AUDIO LEVEL control on the PLL3-R modulator board. To set it properly a deviation meter will be required. This should be connected to the front panel O/P monitor socket. If a deviation meter is not available then the front panel meter should be used, though this will not be as accurate. Apply a 400Hz sine wave at the level required for maximum deviation (normally 75kHz). Adjust the AUDIO LEVEL control to give the required deviation.

If an RDS/SCA unit is to be connected, the output level of it may need re-calibration.

6.5 VSWR CUT-BACK LEVEL

This is the minimum RF output power that the FM30 will provide with a badly matched load such as a defective aerial. It should never be set above 7.5W to protect the power amplifier unit. As supplied it will be set to 5W. To set a

different value turn the FM30 output power down to minimum, connect a power meter to the output and disconnect the dummy load or aerial. Remove jumper LK1 on the FM25DIS PCB. Turn the output power up until the desired reflected power cut-back level is obtained. Replace LK1 and adjust the CUTBACK control (RV2) such that the front panel P. REF LED just changes from RED to GREEN. Turn the output power up to full and if necessary slightly adjust the CUTBACK control to reduce the cut-back level to the value required. Finally reset the forward power to the required level.

LimX PCB (FM30/S Only)

6.6 FET BIAS

Connect an audio input at 400Hz to the LEFT and RIGHT or mono inputs that is below the limit threshold, for example -20dBu.

LimX: Turn R40 and R31 fully anti clockwise. Connect an oscilloscope or level meter to U7 pin 7. Turn R31 slowly clockwise until the level is reduced by 0.1dB. The level will vary whilst R31 is turned. Connect the oscilloscope/level meter to U6 pin 7. Turn R40 slowly clockwise until the level is reduced by 0.1dB. The level will vary whilst R40 is turned.

6.7 MODULATOR INPUT LEVEL

Connect an audio oscillator, level + 8dBu at 1kHz to the MPX IN socket and turn the EXT MPX LOOP switch on (right position). Using a deviation meter, adjust the AUDIO LEVEL control on the PLL3-R PCB to give 75kHz deviation. Return the EXT MPX LOOP switch to the OFF position (left).

6.8 LimX OUTPUT LEVEL

Connect an audio input at 400Hz to the LEFT and RIGHT audio inputs such that the front panel limit LED is fully ON. LINK TP1 on the LimX PCB to ground. This disables the limiters, leaving the clippers active. Switch the pilot off. Adjust R1 to give 75kHz-6.75kHz-(Guard-band) deviation. A typical value would be between 50 and 60 kHz. Disconnect the ground link from TP1.

6.9 INPUT LEVEL

Switch the pilot off. Connect an audio oscillator to the left and right inputs. Set its output to 400Hz and the output level to the desired limit threshold. Turn R15 and R3 fully anti clockwise. Connect an oscilloscope to the MPX OUTPUT connector. Turn R15 clockwise and observe that the peak level shown on the oscilloscope increases. Stop adjusting R3 at the point where the peak level stops increasing. Now adjust R15 clockwise until the waveform is a pure sine wave.

6.10 PILOT LEVEL

Disconnect the audio input. Switch the pilot on. Adjust R86 to give a deviation of 6.75kHz.

If an RDS/SCA unit is to be connected, the output level of it may need re-calibration.

DLM3 PCB (FM30/M Only)

6.11 FET BIAS

Connect an audio input at 400Hz to the Mono input that is below the limit threshold, for example -20dBu.

Turn R33 fully anti clockwise. Connect an oscilloscope or level meter to U3 pin 7. Turn R33 slowly clockwise until the level is reduced by 0.1dB. The level will vary whilst R33 is turned.

6.12 MODULATOR INPUT LEVEL

Connect an audio input at 400Hz to the audio input such that the front panel limit LED is fully ON. LINK TP1 on the DLM3 PCB to ground. This disables the limiter, leaving the clipper active. Adjust the AUDIO LEVEL control on the PLL3-R PCB to give 75kHz-(Guard-band) deviation. A typical value would be between 55 and 65 kHz. Disconnect the ground link from TP1.

6.13 INPUT LEVEL

Connect an audio oscillator to the audio input. Set its output to 400Hz and the output level to the desired limit threshold. Turn R19 fully anti clockwise. Connect an oscilloscope to the MPX OUTPUT connector. Turn R19 clockwise and observe that the peak level shown on the oscilloscope increases. Stop adjusting R19 at the point where the peak level stops increasing.

8 Specifications

))

RF Interface ports	Output type N, monitor BNC. All 50Ω
Power output	0 - 30W typ.
Power output stability	< ± 0.5dB ¹ < ± 1.0dB ²
Minimum return loss for full power output	8dB
Frequency range	87.5 to 108 MHz in 50kHz steps
Frequency error	< ± 200Hz ¹ < ± 400Hz ²
Frequency drift (3 month interval)	< ± 200Hz
Frequency adjustment	continuously variable to < ± 10Hz
Mute attenuation (PLL out of lock)	> 90dB
External mute control attenuation at full power	> 50dB
Deviation sensitivity stability ³	< ± 1%
Spurious outputs (87.5 to 137Mhz @ f _c > ± 0.5MHz)	< -100dBc
Harmonic & spurious output (30MHz to 1GHz)	< -72dBc
Synchronous AM (500Hz @ 40kHz dev.)	< 0.5%
AM Hum & Noise	< 0.3%
Input sensitivity for 75 kHz dev.	+ 8dBu (adj)
AF response (MPX Input)	< ± 0.5dB (5Hz-100kHz)
THD	< 0.15% at 75kHz
Power supply	220/230V _{AC} + 10%/-20% 24 - 30V _{DC}
Power consumption	< 80VA
Ambient temperature range (normal conditions)	10 to 40 Celsius
Ambient temperature range (extreme conditions)	-20 to 45 Celsius
Humidity	≤ 90% non condensing
Dimensions	3Ux260mm
Weight	6kg
Dimensions exclude rear panel connectors and front panel heatsink (40mm).	

¹ Under normal operating conditions

² Under extreme operating conditions

³ Under all operating conditions

9 How to contact sbs
))

For all enquiries write to:-

sbs
PO Box 100
Hastings
East Sussex
TN35 4NR

Or telephone 01424 445588 within the UK, + 44 1424 445588 from outside the UK.

Or fax 01424 443388 within the UK, + 44 1424 443388 from outside the UK.

Or email sales@sbsfm.com for sales enquiries or support@sbsfm.com for technical support.

Alternatively visit our web site: <http://www.sbsfm.com/>

10 Technical Section Contents
))))))))))))))))))))))))))))))))))

- 10.1 Introduction
- 10.2 PLL3 Modulator
- 10.3 FMTX PSU DC-DC Convertor
- 10.4 FM30 PA Amplifier
- 10.5 FMTX-DIS Power distribution and metering/control
- 10.6 LimX Combined Limiter/stereo encoder
- 10.7 DLM3 Limiter
- 10.8 Power supply flow diagram
- 10.9 Wiring diagrams

10.1 Introduction

))

The FM30 transmitter/exciter is built around several distinct PCB modules, broadly as outlined in the block diagram of section 7. Each PCB performs a separate, distinct function. The only minor exception to this being the separation of the digital and analogue functions of the modulator onto two boards. To fully understand the operation of the FM30 it will be necessary to know how each board is interconnected with the other sections of the unit.

10.2 PLL3

))

AUDIO STAGES

The baseband/audio input enters the PLL3/R board via a pin near R62. It is fed, via potentiometer R34 to IC6, which serves as an input buffer amplifier.

The output from IC6 feeds, via R39 and C48, to the modulator AF input. Also fed from the output of IC6 via C43 and a potentiometer R40 (meter sensitivity) is IC7 which is a rectifier stage. This provides the drive for the deviation meter (where fitted).

Both of these stages are supplied from a single rail. This is made possible by deriving a half rail 'ground' using resistors R44 and R45 as a potential divider. This is then decoupled by capacitors C50 and C51.

VOLTAGE CONTROLLED OSCILLATOR

A Colpitt's oscillator is formed by cascoded transistors TR3/4. The frequency of oscillation is determined by L4 and the parallel capacitance provided by varicap diodes D1 and D2. These diodes are biased by the control voltage output from the loop filter. Diode D3 is also biased by this voltage via R14. This diode equalises the modulation sensitivity across the entire band. This is achieved by varying the coupling of varicap diode D4 into the tuned circuit formed by D1, D2 and L4. D4 is the modulation diode. It obtains DC bias via R17, R16 and decoupling capacitor C19. The bias is optimised for minimum audio distortion. The audio modulating signal is applied to this diode via C48 and R18.

A sample of the oscillator frequency is taken from the base of TR4 via C14 and fed to IC1 which is configured as a $\div 40$ pre-scaler. This is then fed to the PLL3-D PCB.

RF AMPLIFIER

The input to the RF amplifier stage is taken from the collector of TR3 via C9. This is amplified by TR2. The gain of this stage is controlled by potentiometer R60 (Output level). The collector of TR2 is tuned by L3. The DC supply for this stage is derived from the output of IC3. This IC switches the supply voltage to mute the output whilst the PLL is out of lock. The full operation of this circuit is explained later.

The next amplifier stage is fed from the collector of TR2 via C7/C6 which act as a matching network into TR1. This is the final amplifier on the PLL3-R board. The bias to this stage is also derived from the output of IC3, via R2 to further increase the attenuation in the muted condition. L15 and its associated components form a low pass filter.

PLL LOOP FILTER

The control voltage from the PLL3-D board is filtered by R33/C38. The filtered control voltage then feeds IC4, a quad switch, via R32 and separately by buffer IC5. The output from IC5 is only used when the PLL is out of lock. Its purpose is to increase the loop bandwidth thus accelerating the time for the PLL to reach its required frequency. The switching for this is done by IC4. In the out of lock condition R29 is placed in parallel with R30 and the output of IC5 is coupled to the output of the loop filter by R31. The low resistance of R31 effectively overrides the in lock path for the control voltage via R32.

When in lock IC5's output is switched out of circuit, as is R29. The control voltage passes to the loop filter output via R32. It is filtered via R30 by C36, giving a very long time constant. The purpose of this long time constant is to prevent the loop responding to very low modulation frequencies and thus causing distortion/phase shift.

The remaining switches in IC4 are configured as a timer (using C35 and R63/R28). In the lock condition C35 is charged via the R63/R28, switching on the final gate of IC4 after a short delay. This gate is used to link the junction of R26 and D10 anode to ground when in lock. The lock LED, D5, is driven via R26. Linking D10 to ground removes the positive bias (via R26 and R27/D5) applied to the input of IC3 causing its output to go high (+ 15V). The output of IC3 is used to drive the RF amplifier, as described above. The reason for the delay is to allow the loop to stabilise after the long time constant filter is switched in.

PLL3-D DIGITAL BOARD

Incoming clock pulses from IC1 on the PLL3-R board (output frequency ÷ 40) enter this PCB via PL2 pins 4/13. This is fed to TR1 which shifts their level from $8V_{PK}$ to the $15V_{PK}$ that is required by IC1.

IC1 is a programmable divide by N counter. The purpose of this is to divide the clock frequency by a ratio defined by the setting of the four frequency set switches and the 50kHz shift switch.

The divided output can be monitored at TP3. It should be noted that this output consists of pulses of the same duration as the incoming clock. The duty cycle is therefore very low. It may be difficult to see this on an oscilloscope .

IC4 is a crystal controlled reference oscillator and divider. The crystal frequency of 5.120MHz can be trimmed over a small range by C14. The output frequency

of 1.25kHz is taken from Pin 1. This can be checked at TP4. This is the reference frequency used by the PLL.

IC2 is a CMOS 4046 phase locked loop. It compares the phase of the divided VCO signal from IC1 with the output of the reference oscillator. It has two outputs; one from pin 13 (TP5) is fed via PL2 pins 8 and 9 to the loop filter on the PLL3-R PCB. The network R1/C1 is a low pass filter with a much shorter time constant than that of the loop filter. This reduces the tendency for output transitions from IC2 producing spurious sidebands. The other output feeds the lock detector circuit, IC3.

IC3 is an integrator whose output is low when the PLL is in the locked condition. It feeds the loop bandwidth control on the PLL3-R PCB via pins 5 and 12. Its output can be monitored at TP2.

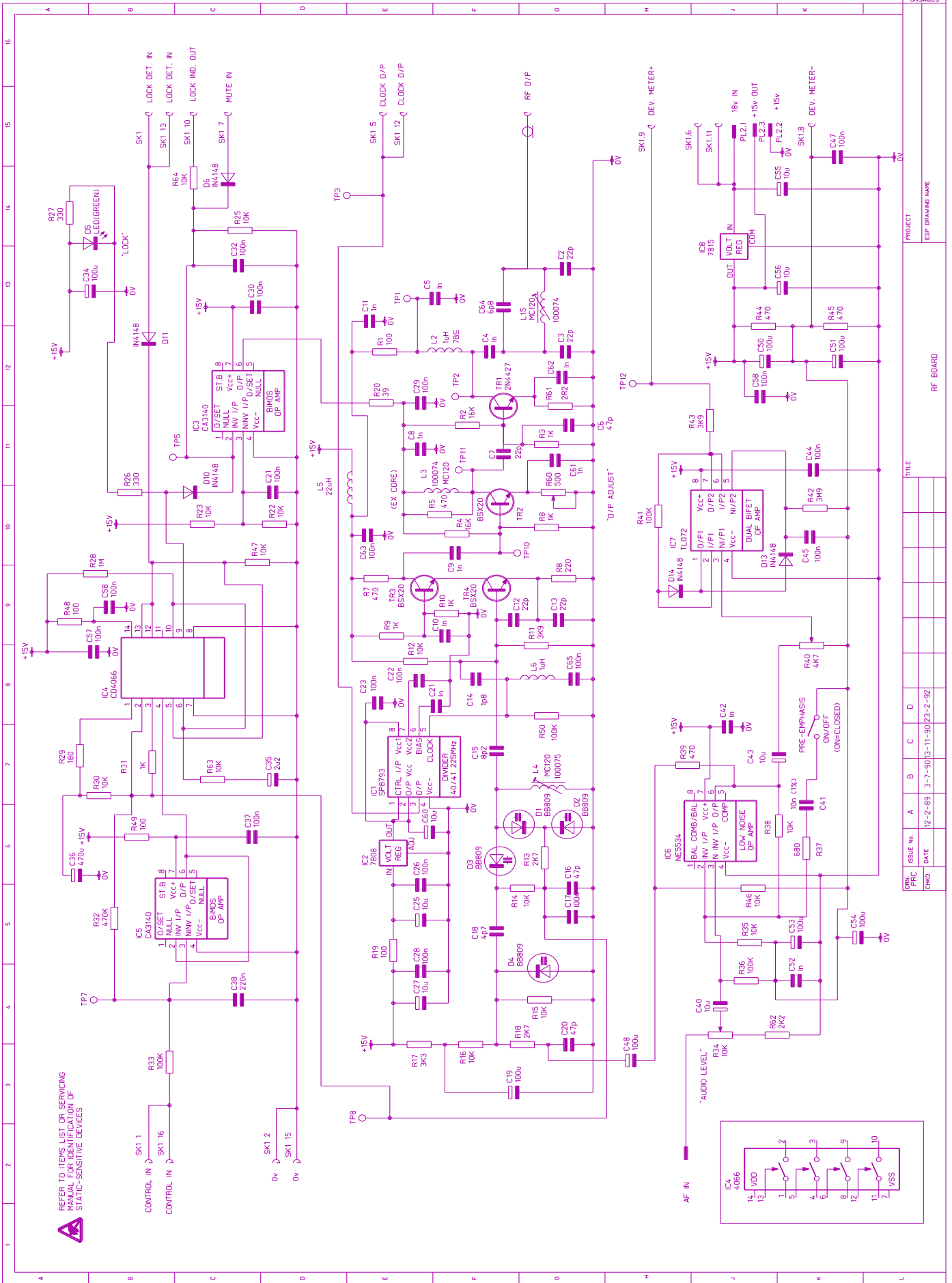

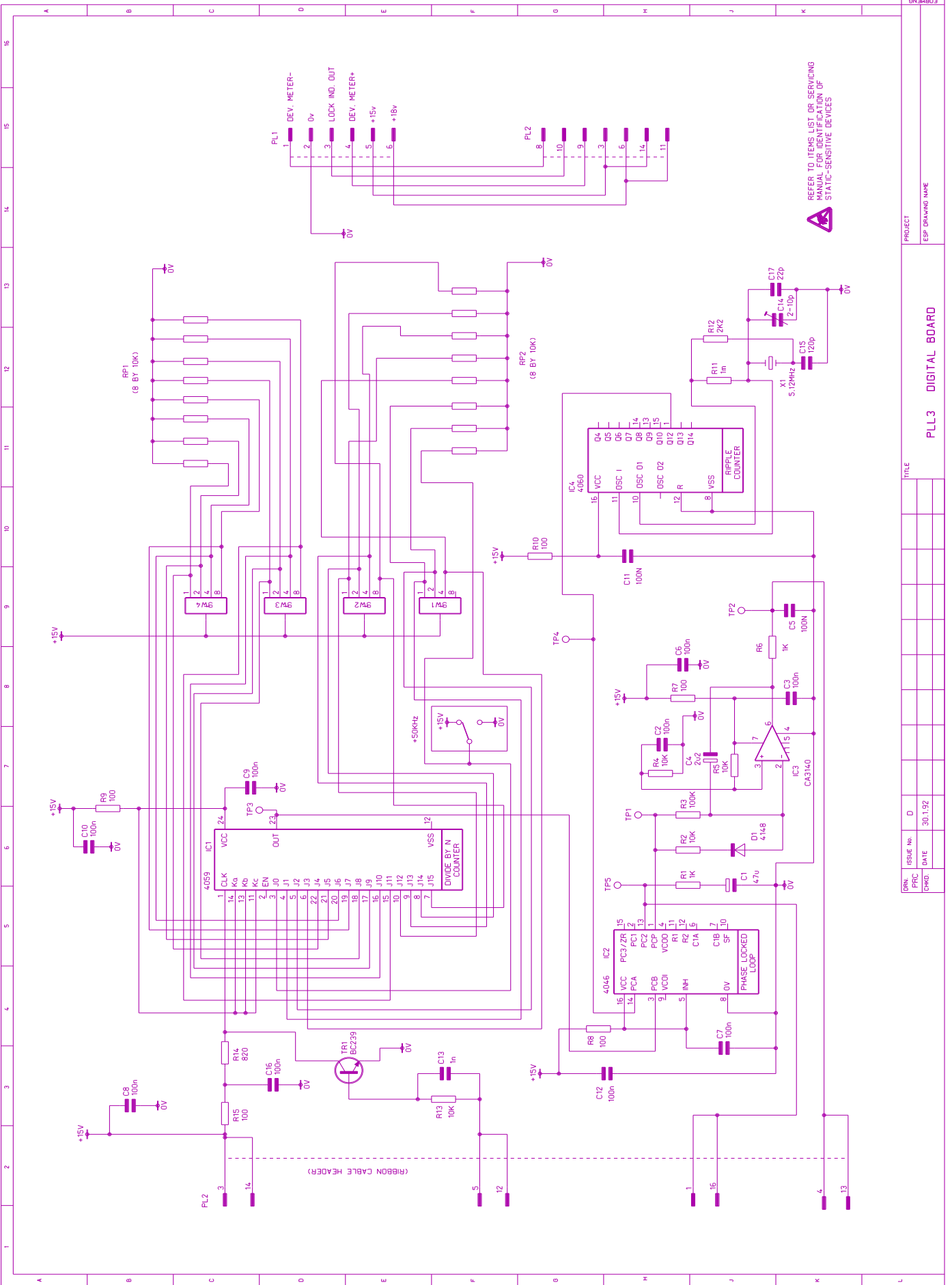

REFER TO ITEMS LIST OR SERVICING
MANUAL FOR IDENTIFICATION OF
STATIC-SENSITIVE DEVICES



PROJECT ESP DRAWING NAME				
TITLE PL3 DIGITAL BOARD				
DRN.	ISSUE No.	D	DATE	30.1.92
PFC	DATE			
CHKD.				

10.3 FMTX-PSU

)))))))))

The power supply takes its input from the unregulated DC supply. It is used to supply the RF power amplifier with its DC supply. This supply must vary between 5V and 15.5V dependent on the output power required.

The supply is designed around a SGS-Thomson step-down switching voltage regulator, type GS-R400V. This supply provides soft start, inhibit, over current and over voltage protection.

The DC input to the board is fused at 10A (fast acting). This fuse should only fail if the converters internal over-voltage crowbar trip operates. This will normally only happen if there has been an internal failure in the convertor. The fuse must only be replaced with a fast acting type of the same value.

The DC supply is decoupled at the convertor input by C1 (Low ESR type). The same type of capacitor, C2 is used to decouple the convertor output.

The output voltage is set by the parallel combination of R4 and the external 10k Ω power set control. The parallel value of these two components is 6k Ω for 15.5V (maximum power) and 0 Ω for 5.1V. The VSWR cut-back system feeds a positive current into the VAR input when it operates, to reduce the output voltage (and therefore output power).

T2, R8, R6, R7 and zener diode D2 provide over voltage protection in the event that the power set control should become open circuit, through disconnection or failure. This prevents damage to the RF power amp unit. This part of the circuit is designed only for protection. It should not be used to control the output in normal conditions since the output stabilisation and noise performance will be degraded.

The power supply can be shut down to provide the muting facility using the inhibit inputs. A positive voltage > 5V can be supplied to the convertor via D3 and the potential divider R2/R3. Alternatively R5 can be linked to ground, turning on T1. The former input is connected to the PLL Out of Lock output from the PLL3 modulator and the latter is linked to the rear panel control connector to provide the external mute facility.

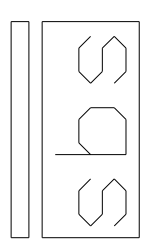
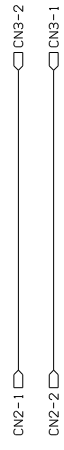
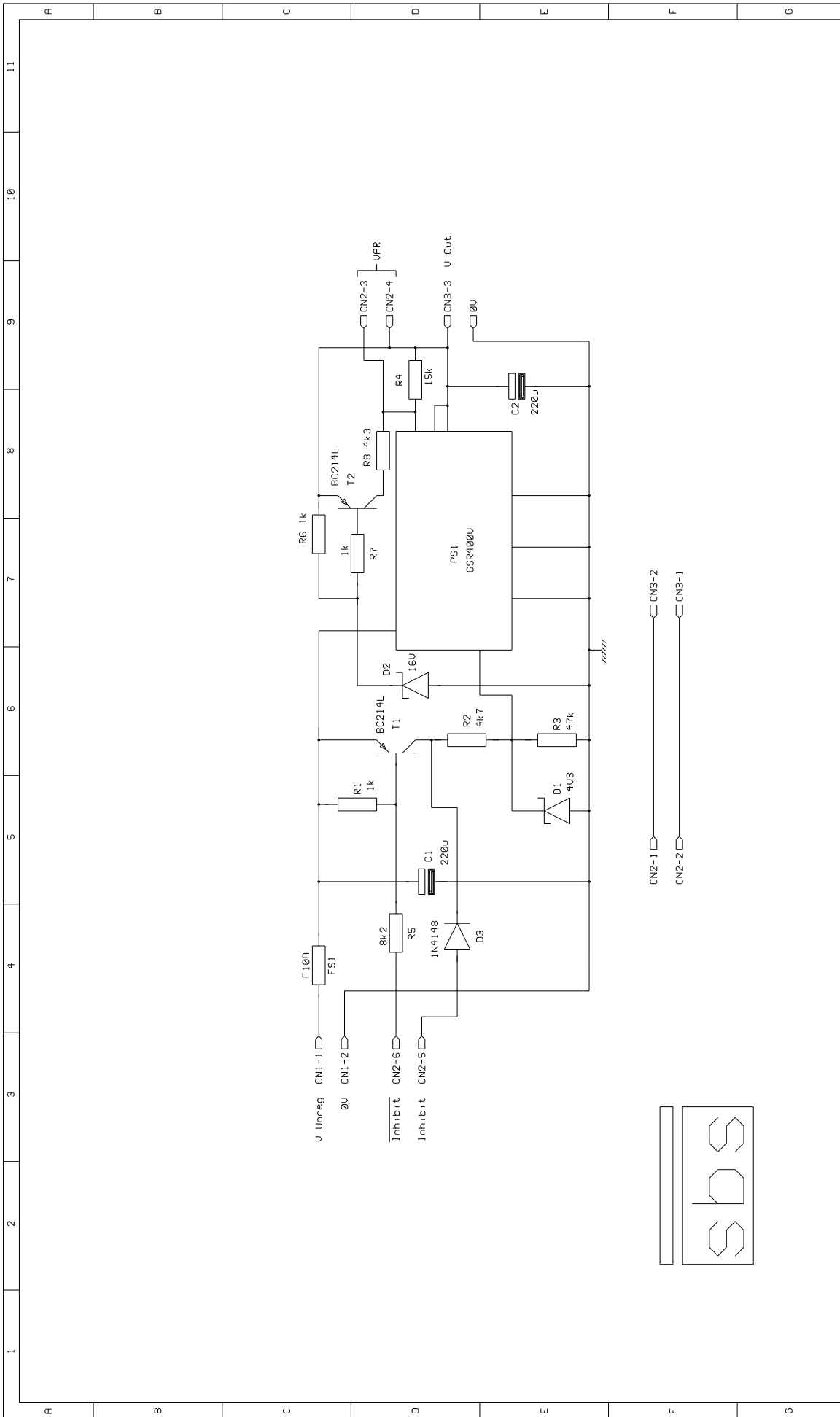

Title		5V to 15V PSU		Issue		A		Drawn By		DBS	
Date		13 06 00		Date				Drawing No		FM30PSU SCH	
Project		FM30		Project							

10.4 FM30 PA

))

The FM30 30W amplifier is a 2 stage design, using a pair of Semelabs MOSFET devices. The DC input voltage to the amplifier can vary between 5-15.5V depending on the required output power.

Resistors R9, R10, R11 form an input attenuator. The input matching circuit for U1 comprises L2, 2:1 transformer T2 and R8. C6 provides DC blocking. Bias is applied to the gate of U1 via R2.

U1 is a surface-mounted device. If replacement of U1 is required, it is essential to use the correct hot-air rework equipment. Use of a soldering iron may damage the PCB and device.

U1's output is matched to the input of the main output device U2 by C3, C4, C10, two lengths of strip-line and R7. DC bias for U2 is generated by D1 which rectifies the RF input at the appropriate point on the strip-line matching section. This arrangement removes the bias from U2 if the RF input is removed. Output matching from U2 is done with a length of strip-line and C18, C7, C8, C19 and L3.

The first two sections, C11,L5, L6, C14, C15 and C20, of the output filter are tuned to the 2nd and 3rd harmonics with the final low pass filter stage comprising L7 and C13. A strip-line directional coupler is used to sense the forward and reflected power levels. R12 nulls the reflected power sensor.

6 5 4 3 2 1

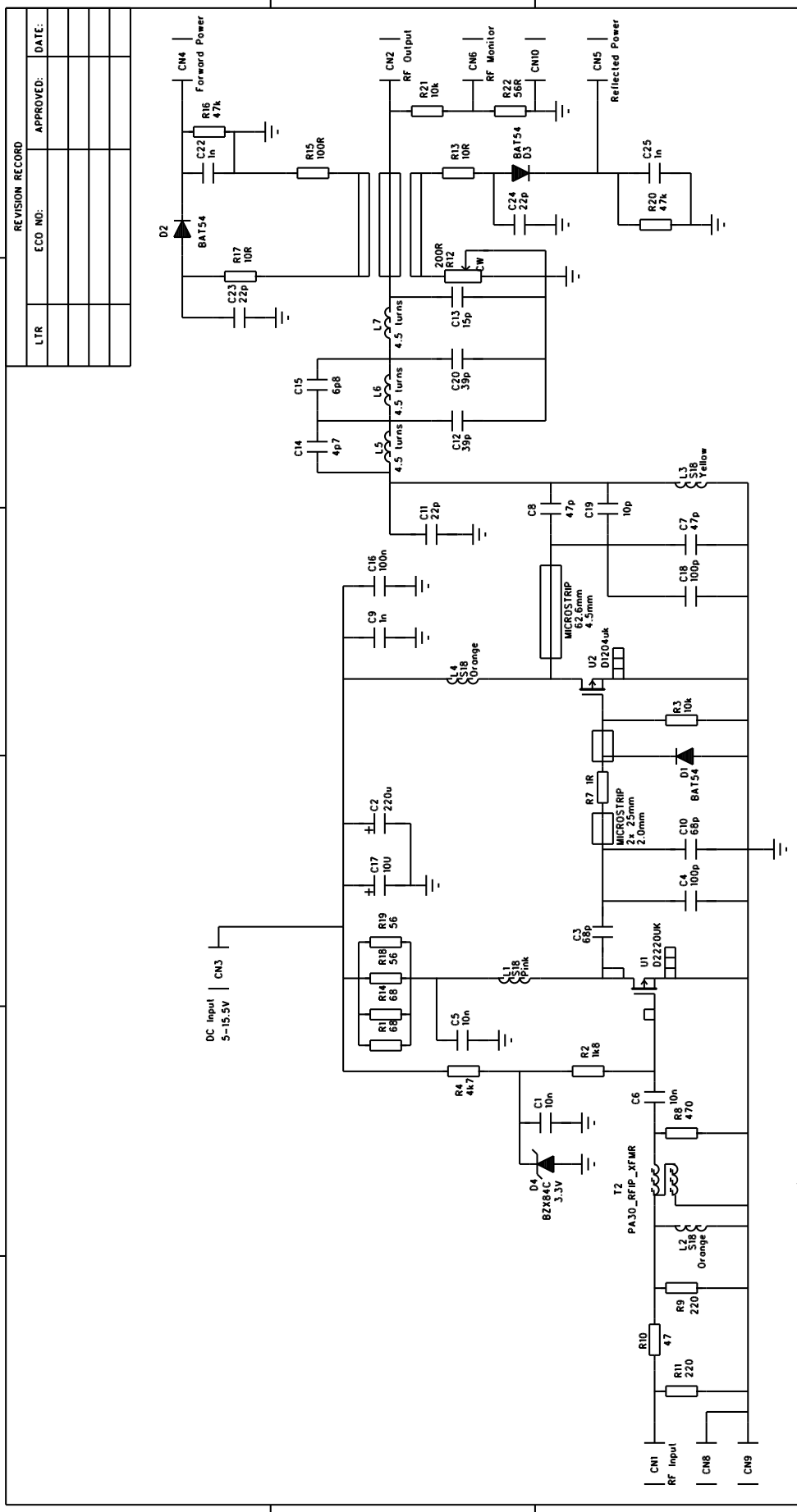

COMPANY: SBS		DRAWN: MLC		DATED: 08/03/00	
TITLE: 30 watt PA Section		CHECKED:		DATED:	
CODE:		QUALITY CONTROL:		DATED:	
SIZE:		RELEASED:		DATED:	
DRAWING NO:		SCALE:		SHEET: OF	
REV:					

10.5 FMTXDIS

))

The FM25DIS PCB performs three tasks:- The basic power supply function, a central point for the interconnection of the other PCB's and indicators and the VSWR cut-back system.

The AC output from the mains transformer is connected to the bridge rectifier. The output from the bridge rectifier enters the FMTXDIS board at connector CN1 pins 1 and 2. It is smoothed by C1. The external DC input enters the PCB at connector CN1 pins 3 and 4, reverse voltage protection is provided by D1. The mains derived DC supply is monitored by TR1 and its associated components. Should this supply drop below about 20V the relay RL1 will be switched off selecting the external DC input. D3 ensures that power is drawn from the mains derived DC supply if the external supply is lower or absent. D3 also takes the load current during the relay change-over time.

From this point this unregulated supply feeds the FMTX-PSU via connector CN7 pins 1 and 2, the front panel meter via R2 and connector CN3 pin 3 and IC1 which is a 7818 voltage stabiliser. The output from IC1 supplies most of the FM25DIS board electronics and the PLL3 boards via connector CN4 pin 6. IC2 receives a 15V supply from the PLL3 boards via connector CN4 pin 5.

Transistors TR2, TR3 and TR4 provide the PLL LOCK LED drive and the external PLL LOCK OK indications. TR2 is turned off when the PLL is in lock. This in turn will turn on TR3 and TR4.

The forward power sensed voltage enters the board via connector CN5 pin 2. It is buffered and amplified by IC2b. The meter is driven via RV3. IC4 is operated as a comparator with its threshold set by RV4. Transistor TR9 drives the external forward power OK indication. Transistors TR10 and TR11 drive the front panel P FWD LED.

The reflected power sensed voltage enters the board via connector CN5 pin 1. It is buffered and amplified by IC2a. The meter is driven via RV1. C4 is charged by R11, R12 and D5. This provides a rapid peak hold with a slower decay. IC3 further amplifies this voltage. The gain of this stage (and therefore the maximum amount of cut-back) is set by RV2. The output of IC3 drives the control input of the FMTX-PSU unit via LK1, TR5, D6, R17 and pin 3 of connector CN5. Feeding a positive current into this control input reduces the power supply output and therefore the RF output power and the consequent reflected power. The output power potentiometer is connected between pins 7 and 8 of connector CN2. The purpose of TR5 is to turn on TR6 as soon as the cut-back system starts to operate. TR6 drives the red part of the P REF LED and turns on TR7 which will turn off TR8.

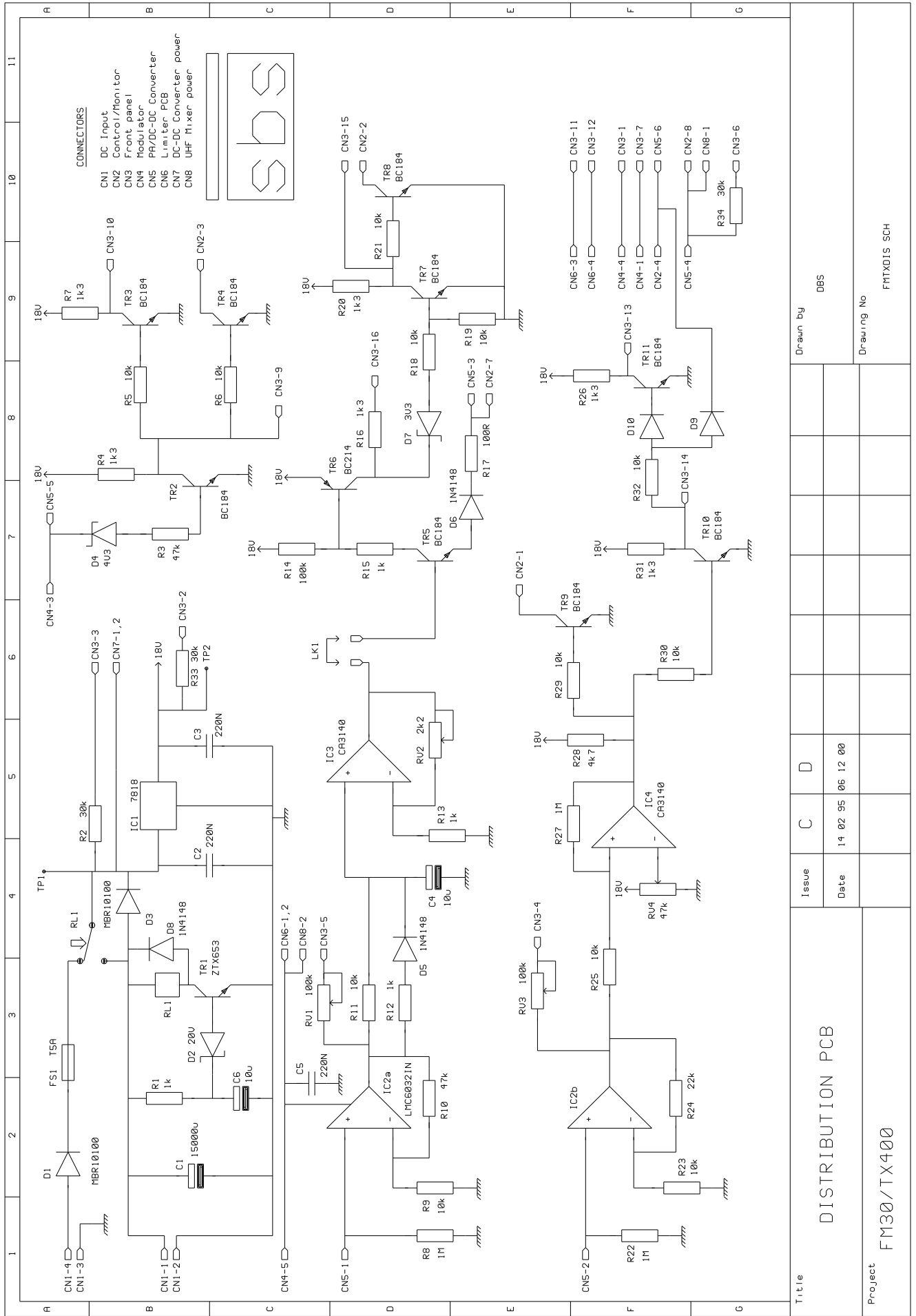

Title
 Issue C D
 Date 14 02 95 06 12 00
 Drawn By DBS
 Drawing No FMTXD15 SCH

DISTRIBUTION PCB

Project FM30/TX400

10.6 LimX

)))))) LimX)))))))))

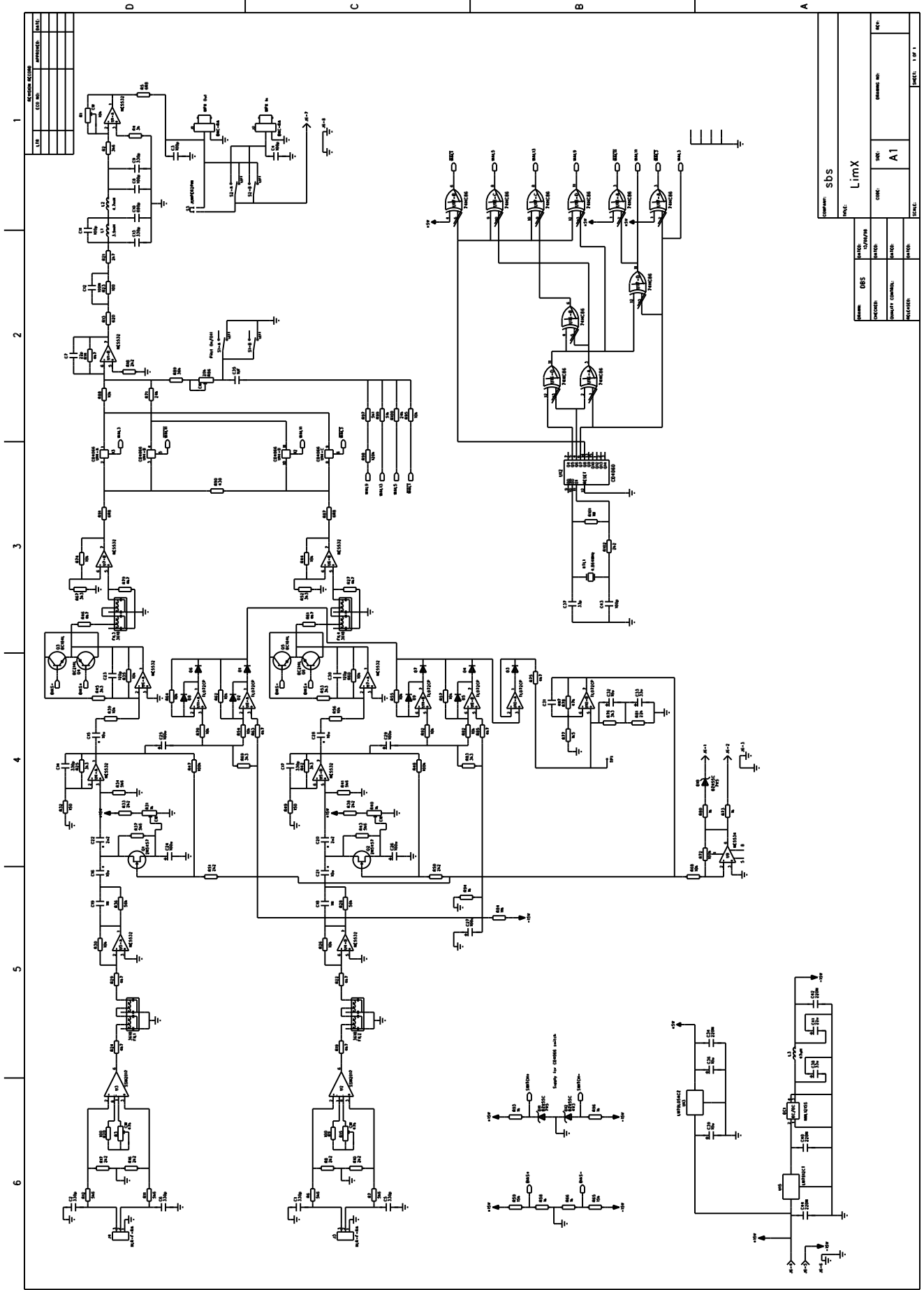

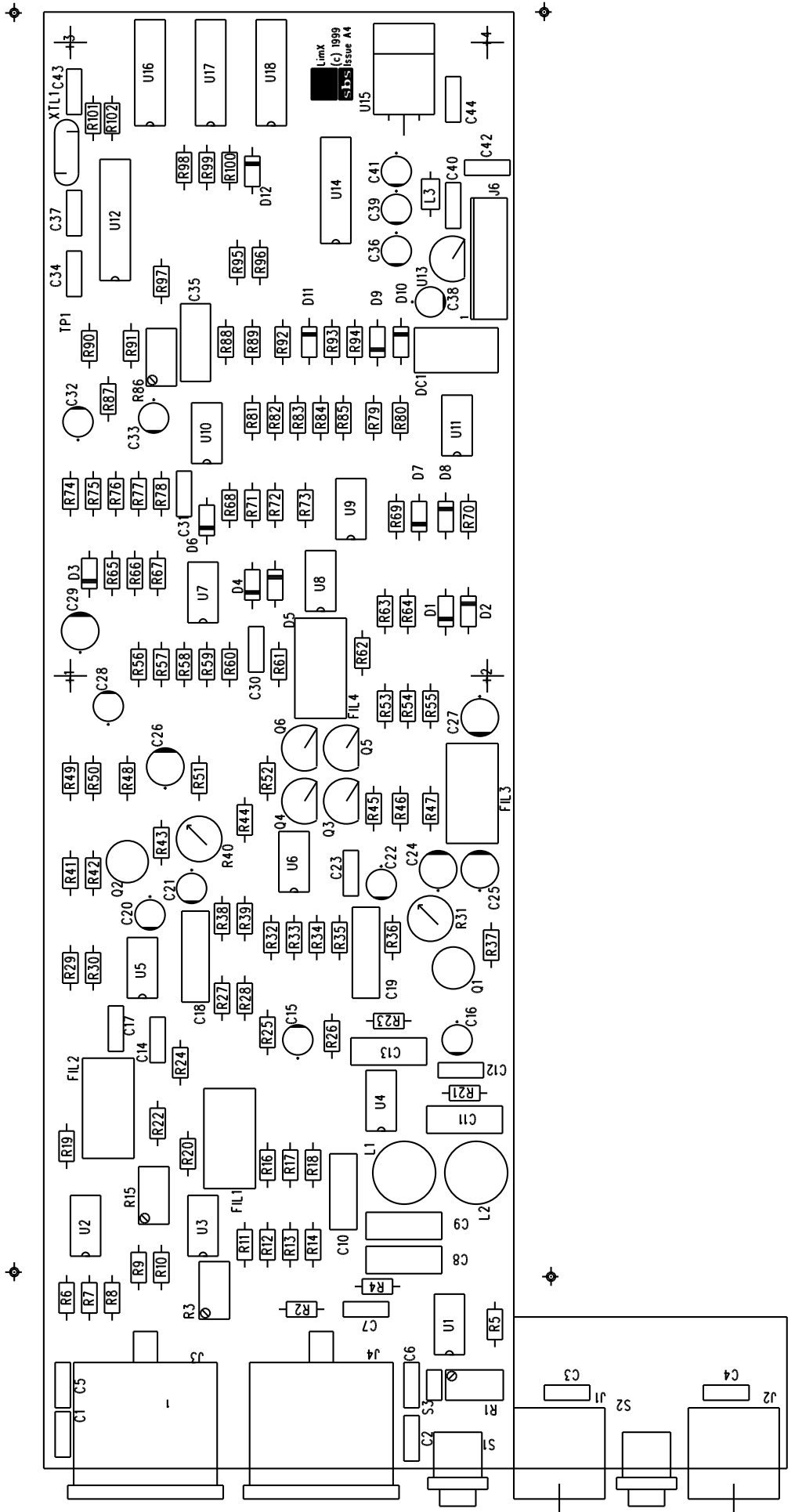

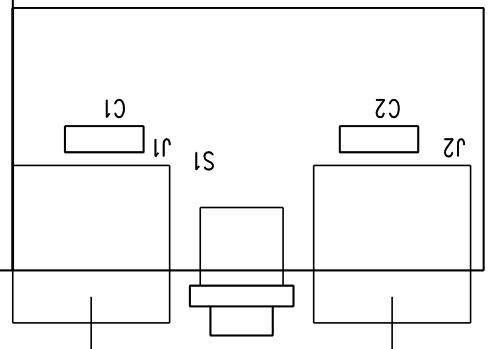
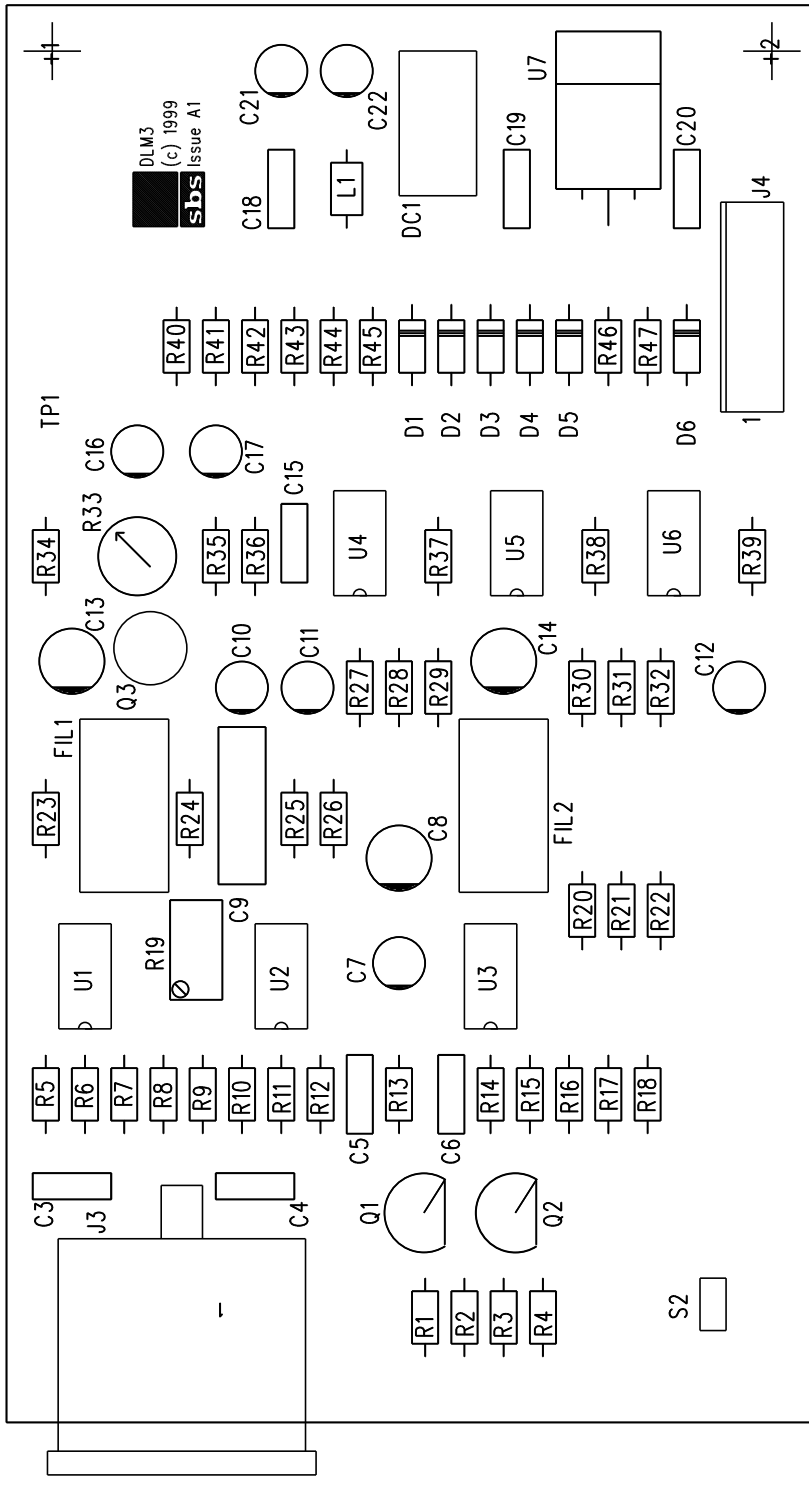

10.8 Power supply flow diagram

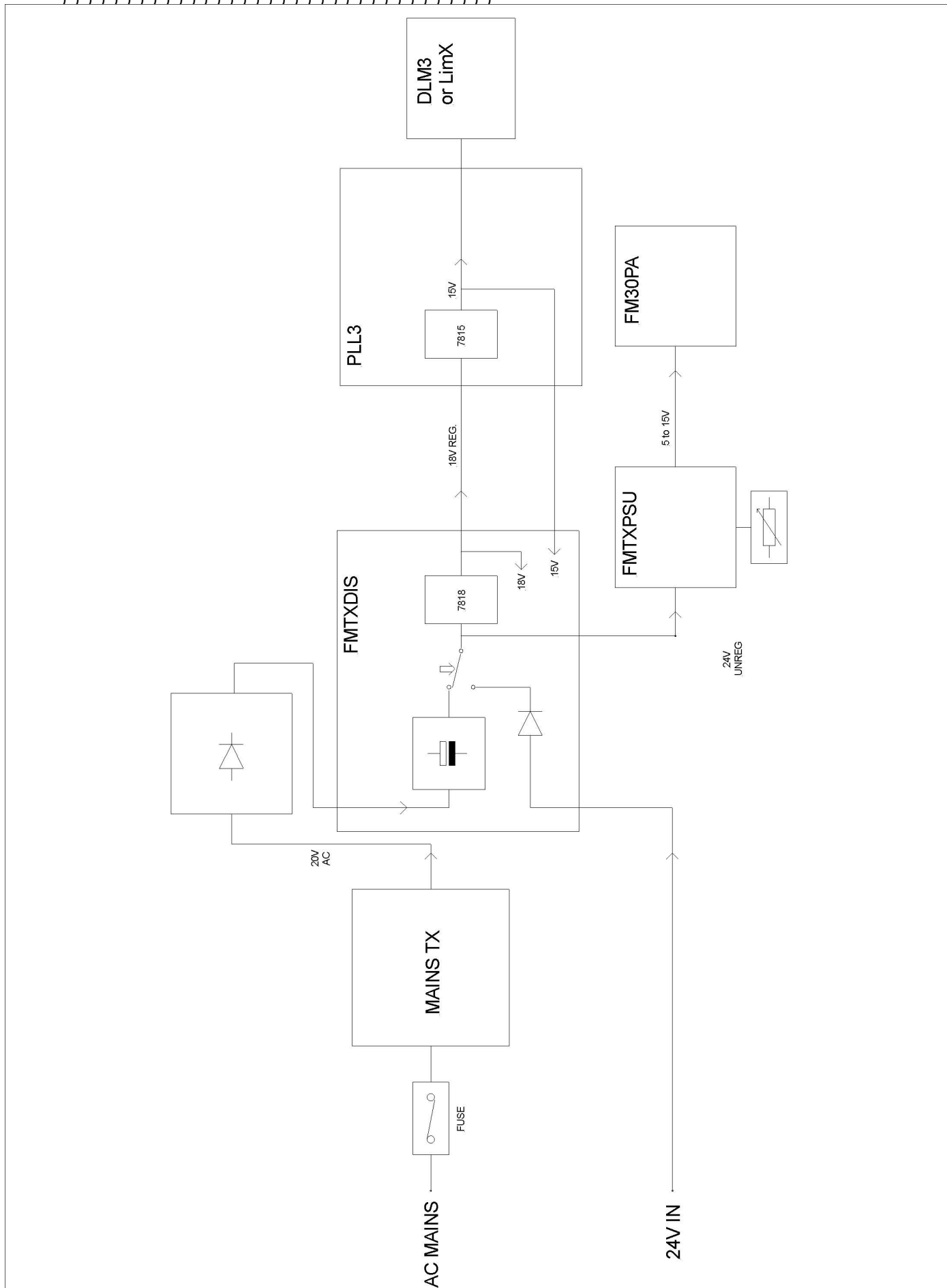
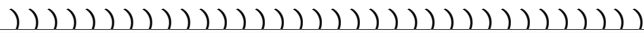

10.9 Wiring diagrams

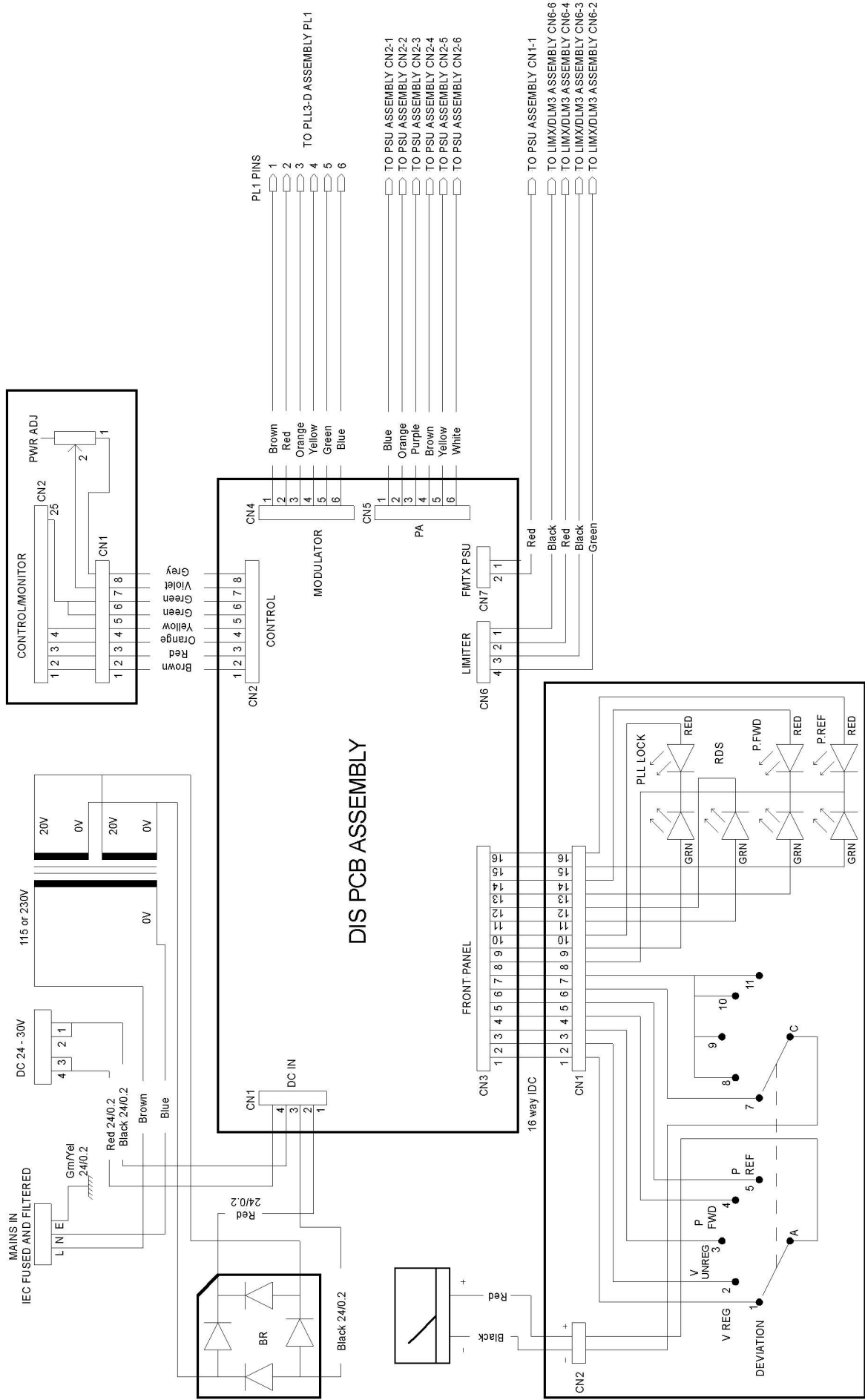

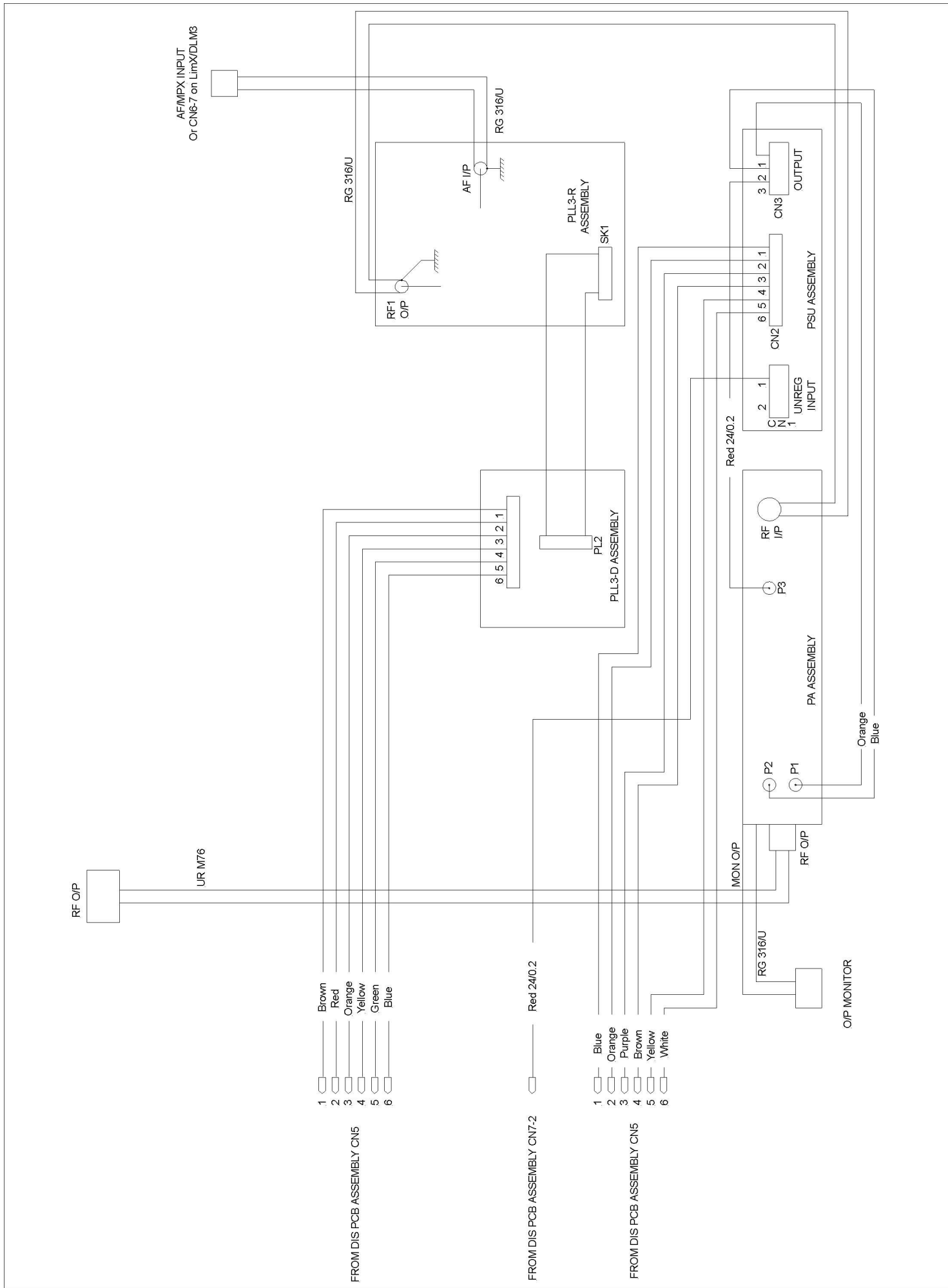

11 Declaration of conformity

))

Name of Manufacturer: sbs
Address of Manufacturer: PO Box 100
HASTINGS
East Sussex
TN35 4NR

Product: FM30 FM Exciter

Declaration:

The product described above compiles with the requirements of the Low Voltage Directive (73/23/EEC) and the protection requirements of the EMC Directive (89/336/EEC) issued by the Commission of the European Community.

Compliance with these directives implies conformity to the following European Standards:

- EN 60065:1998 Safety requirements for mains operated electronic and related apparatus for household and similar general use
- EN 50081-2:1994 Electromagnetic compatibility. Generic emission standard. Industrial environment
- EN 50082-2:1995 Electromagnetic compatibility. Generic immunity standard. Industrial environment

Additionally, the product described above complies with all relevant parts of the following standards:

- ETS 300 384:1995 Radio broadcasting systems; Very High Frequency (VHF), frequency modulated, sound broadcasting transmitters

Signed:		Date of Issue:
	On file	16 . 05. 2002
for and on behalf of sbs, UK	Pyers Easton CEO	